

PROJECT MANUAL FOR:

**Springfield Park District
Springfield Rink Floors and Plant Replacement
Springfield, IL**

For:

**Springfield Park District
2500 South 11th Street
Springfield, IL 62703**

By:

**Jason Graham, Director of Parks and Planning
Springfield Park District
2500 S. 11th St.
Springfield, IL 62703**

**Springfield Park District
Springfield Rink Floors and Plant Replacement
Springfield, IL**

Table of Contents:

Advertisement for Bids

P.A. No. 100-1177

Ordinance # 1117-07

Ordinance # 1118-07

Ordinance # 1161-08

Instruction to Bidders

Summary of Quantities

Bid Form

Contractor Qualification Sheet

Bid Bond Form

Special Provisions

Acceptance or Non-Acceptance of Tenders

Contract

Notice to Proceed

Change Order

Appendix A: Contract Specifications

Appendix B: Contract Drawing Package

Appendix C: Project Schedules

Appendix D: Bidder Evaluation Criteria

ADVERTISEMENT FOR BIDS

Springfield Park District
2500 South 11th Street
Springfield, IL 62703

Will receive sealed bids for: Springfield Rink Floors and Plant Replacement

Contract Documents I.B. Storey US Inc., Joshua Ritchie
Prepared by: 17900 Gulf Blvd., Suite 3F
 Redington Shores, FL 33708

PROJECT DESCRIPTION

This replacement consists of life cycle upgrades of the refrigeration system and concrete floors for the ice rink, as well as other rink engineering components. It comprises all fully operational and functional elements, including equipment, software, and programming interfaced to the associated work of other related trades. This includes packaged refrigeration systems, pumps, refrigeration field piping, water field piping, automation equipment, automation programming, instrumentation, a dasher board system, concrete work for the cold and warm floor, an adiabatic fluid cooler stand, housekeeping pads, and electrical work.

BIDDING REQUIREMENTS

All bidders are required to comply with the provisions of P.A. No. 100-1177, No. 1117-07 (Responsible Bidders Ordinance), No. 1118-07 (Project Labor Agreement) and No. 1161-08 (Substance Abuse Policy).

TIME AND PLACE OF BID SUBMITTAL

The Owner will receive sealed bids until 2:00 p.m. CT on 01-Nov-24, at which time the bids will be opened publicly. Bids are to be delivered to the Board Room in the Springfield Park District office, located in Bunn Park.

Bids should be directed to Mr. Jason Graham, Director of Parks & Planning
 Springfield Park District
 2500 South 11th Street
 Springfield, IL 62703

Bids received after stated time will not be accepted and will be returned unopened.

TIME AND PLACE OF PRE-BID MEETING

A non-mandatory Pre-Bid Meeting will be held at 1:00 p.m. CT on 24-Oct-24. The meeting will be held at the Nelson Center Ice Rink located at 1601 N 5th St., Springfield, IL 62702.

CONTRACT DOCUMENTS

Until bids have been opened, plans and specifications shall be on file in the office of the Springfield Park District, 2500 South 11th Street, subject to the inspection of all parties desiring to bid. The Board of Trustees of the Springfield Park District reserves the right to waive any irregularities in the bids, reject any or all bids and to accept any bid deemed most advantageous to the district.

Obtain bidding documents at the office of the Springfield Park District located at 2500 South 11th Street (217-544-1751). A twenty-dollar (\$20.00) deposit is required. Checks shall be made payable to Springfield Park District. Electronic file available also.

BID STIPULATION

Bids shall be submitted in sealed envelopes marked "Springfield Rink Floors and Plant Replacement". An accompanying bid bond shall be equal to 10% of the total bid price. This may be in the form of a Certified Check, Bank Draft, or Bid Bond payable to the Owner.

Contractor shall not pay less than the prevailing rate of wages as determined by the Department of Labor to all laborers, workmen, mechanics performing work under this contract, and shall comply with the requirements of the Illinois Wages of Employees on Public Works Act.

The successful Bidder will be required to furnish a satisfactory Performance Bond and a Labor and Material Payment Bond for the full amount of the bid accepted.

Owner reserves the right to reject any or all proposals, to waive technicalities and minor irregularities in bidding, and to award a Contract for any part of the Work or the Project as a whole.

The Springfield Park District is an Equal Opportunity Employer. Minority business firms are encouraged to submit a bid for this project.

Bids shall include the following information which will be used to evaluate bidders as per Appendix D Bidder Evaluation Criteria:

1. A brief description of the company. Include a history of the company size, location, and areas of professional expertise. Specification of recommended installation, with detail that meets or exceeds the specifications outlined in the scope of work.
2. Stipulate that installation will occur as necessary to fulfill applicable codes and standards as they apply to refrigeration and mechanical systems.
3. A list of the key personnel who would be involved including any sub-consultants or sub-contractors.
4. Clearly outline demonstrated experience and understanding of mechanical concepts, including a summary of projects undertaken in the recreation sector, a summary of projects

involving refrigeration system installations, and a summary of projects involving specialized rink floor construction. Description of refrigeration qualifications/certifications.

5. Only companies having successfully completed a minimum of 5 separate mechanical/refrigeration system installations shall be qualified to bid this project. To establish competency and proof of ability the contractor shall submit a list of references including phone numbers and contacts.
6. Provide a proposed construction schedule for the installation of the mechanical refrigeration plant replacement and specialized rink floor construction project. A schedule of any required demolition and erection of walls to enable equipment installation and relocation must be submitted for approval.
7. Proponent shall provide the total cost of the project. The proposed cost is to be turnkey. Taxes are to be added as a separate item.

MILESTONE DATES

Tender Posting	14-Oct-24
Non-Mandatory Pre-Bid Meeting	24-Oct-24
Deadline for Questions	29-Oct-24
Tender Closing	01-Nov-24
Substantial Completion	24-Sep-25

PREVAILING WAGE ACT

Any contract that calls for the construction of a “public work,” within the meaning of the Illinois Prevailing Wage Act, 820 ILCS 130/.01 *et seq.* (“the Act”). The Act required contractors and subcontractors to pay laborers, workers and mechanics performing services on public works projects no less than the “prevailing rate of wages” (hourly cash wages plus fringe benefits) in the county where the work is performed. For information regarding current prevailing wage rates, please refer to the Illinois Department of Labor’s website at: <http://www.state.il.us/agency/idol/rates/rates.HTM>. All contractors and subcontractors rendering services under such contract must comply with all requirements of the Act, including but not limited to, all wage, notice and record keeping duties.

ORDINANCE NO. 1404-17

**AN ORDINANCE OF THE SPRINGFIELD PARK DISTRICT
ADOPTING THE PREVAILING WAGE RATE**

WHEREAS, the State of Illinois has enacted "AN ACT regulating wages of laborers, mechanics and other workers employed in any public works by the State, County, City or any public body or any political subdivision or by any one under contract for public works," approved June 26, 1941, as amended, also known as the Prevailing Wage Act, (820 Illinois Compiled Statutes, Section 130/0.01 et. seq) and

WHEREAS, the aforesaid Act requires that the SPRINGFIELD PARK DISTRICT of the City of Springfield, Illinois, investigate and ascertain the prevailing rate of wages as defined in said Act for laborers, mechanics and other workers in the locality of Springfield, Illinois, employed in performing construction of public works, for said SPRINGFIELD PARK DISTRICT.

NOW THEREFORE, BE IT ORDAINED BY THE PRESIDENT AND BOARD OF TRUSTEES OF THE SPRINGFIELD PARK DISTRICT:

SECTION 1: To the extent and as required by "An Act regulating wages of laborers, mechanics and other workers employed in any public works by State, County, City or any public body or any political subdivision or by any one under contract for public works," approved June 26, 1941, as amended the general prevailing rate of wages in the locality for laborers, mechanics and other workers engaged in construction of public works coming under the jurisdiction work in the Sangamon County area as determined by the Department of Labor of the State of Illinois as of June of the current year a copy of that determination being attached hereto and incorporated herein by reference. As required by said Act, any and all revisions of the prevailing rate of wages by the Department of Labor of the State of Illinois shall supersede the Department's June determination and apply to any and all public works construction undertaken by the SPRINGFIELD PARK DISTRICT. The definition of any terms appearing in this Ordinance where are also used in aforesaid Act shall be the same as in said Act.

SECTION 2: Nothing herein contained shall be construed to apply said general prevailing rate of wages as herein ascertained to any work or employment except public works construction of the SPRINGFIELD PARK DISTRICT to the extent required by the aforesaid Act.

SECTION 3: The SPRINGFIELD PARK DISTRICT SECRETARY shall publicly post or keep available for inspection by any interested party in the main office of the SPRINGFIELD PARK DISTRICT this determination or any revisions of such prevailing rate of wage. A copy of this determination or of the current revised determination of prevailing rate of wages then in effect shall be attached to all contract specifications.

SECTION 4: The SPRINGFIELD PARK DISTRICT SECRETARY shall mail a copy of this determination to any employer, and to any association of employers and to any person or association of employers and to any person or association of employees who have filed their names and addresses, requesting copies of any determination stating the particular rates and the particular class of workers whose wages will be affected by such rates.

SECTION 5: The SPRINGFIELD PARK DISTRICT SECRETARY shall promptly file a certified copy of this Ordinance with both the Secretary of State Index Division and the Department of Labor of the State of Illinois.

SECTION 6: The SPRINGFIELD PARK DISTRICT SECRETARY shall cause to be published in a newspaper of general circulation within the area a copy of this Ordinance and such publication shall constitute notice that the determination is effective and that this is the determination of this public body.

PASSED: June 15, 2017

APPROVED: June 15, 2017

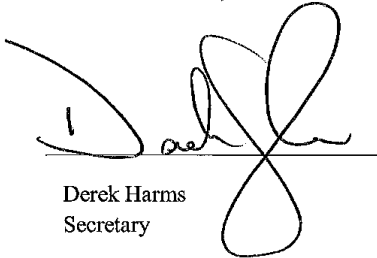

Derek Harms
Secretary

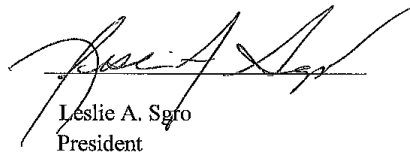

Leslie A. Sgro
President

ORDINANCE #1117-07
Responsible Bidders Ordinance

WHEREAS, the Springfield Park District, from time to time, prepares specifications, advertises, and awards bids, for the construction of various projects, or for the provision of services directly to the residents of the said Park District, and

WHEREAS, the Board of the said Park District desires to award the contracts for the construction of such projects, or for the provision of such services, to the lowest responsible bidder, in accord with the applicable Illinois law, and

WHEREAS, the said Board believes that it is the obligation of the Park District to comply with the various laws, both state and federal, which protect the health, safety, and welfare of the workers who are employed in the construction of its projects, or the provision of services to the residents of the District, and it is further the obligation of the Park District to encourage those to whom such construction or services contracts are awarded to comply with such statutes as well, and it is further the obligation of the Park District to encourage those to whom construction or service contracts are awarded to develop and maintain apprenticeship and training programs in order to provide a pool of qualified and skilled workers in the Springfield area, and

WHEREAS, the Board of the said Park District desires to adopt ordinances and follow practices and procedures designed to ensure, to the maximum extent possible, that it, and those with whom it contracts, do comply with the said state and federal statutes, and do provide apprenticeship and training programs,

NOW THEREFORE BE IT ORDAINED by the Board of the Springfield Park District as follows:

That from and after the passage and approval of this ordinance according to law, all specifications for the construction or substantial renovation of any building, roadway, bridge, shelter, parking lot, or other capital project, or for the provision of services directly to the residents of the said District, shall include a requirement that any person, firm, corporation, or other entity submitting a bid shall include a complete, accurate, and truthful listing and description of all citations, complaints, summons, decisions, determinations, judgments, or other allegations or findings of any violation of state or federal laws which protect the health, safety, or welfare of workers, including but not limited to, OSHA, FMLA, FLSA, ADA, ADEA, NLRA, the Federal Civil Rights Act, The Illinois Human Rights Act, the Illinois Wage and Hour Law, and the Prevailing Wage Act, filed against it or any entity with whom it is submitting the bid, including joint venturers and partners, and also including parent and subsidiary corporations or entities, and shall further include a statement that such bidder is a participant in at least one apprenticeship and training program approved by and registered with the United States Department of Labor's Bureau of Apprenticeship and Training, for the trades or crafts to be utilized on the project being bid, provided however, that the Board may waive the Apprentice and Training program requirement herein if no such program is available to the bidder. If the bidder has not been the recipient of any citations, complaints, summons, decisions, determinations, judgments, or other allegations or findings as aforesaid, it shall include a statement to that effect with its bid.

That any bidder who willfully fails or refuses to include the information required in Paragraph one, or whose report is substantially incomplete, inaccurate, or untruthful, shall be disqualified and its bid rejected.

That the Board may reject any bid and disqualify any bidder whose report, or subsequent inquiry into the matters contained in such report, reveals any of the following:

That there has been a finding, determination, or judgment by an agency of the state or federal government charged with the responsibility of enforcing laws and regulations which protect the health, safety, or welfare of workers, as enumerated above, or otherwise, that the bidder has violated such a statute or regulation, and that such violation was:

1. Found to have been part of a pattern of similar violations, or one of three or more similar violations committed within the two years immediately preceding the submission of the bid, or
2. Classified by an agency of the state or federal government as serious, or
3. One which threatened the health or safety of the workers employed by the bidder, or
4. One resulting in the payment of back wages and benefits of \$5,000 or more, or
5. One that resulted or could have resulted in the debarment of the bidder from contracting with the state or federal government, or any agency thereof.

That the bidder and its employees, do not actively participate in an apprenticeship and training program as aforesaid.

That any person, firm, corporation, or other entity seeking to submit bids for any project of, or for the provision of services to the residents of the said District as herein described, which has been disqualified or had its bids rejected by the Board on three or more occasions within the three years immediately preceding the submission of the bid which is then currently before the Board for consideration, shall be debarred from submitting further bids for such District projects for a period of one year following the rejection of the bid then currently being considered by the Board.

PASSED: September 18, 2007

APPROVED: September 18, 2007

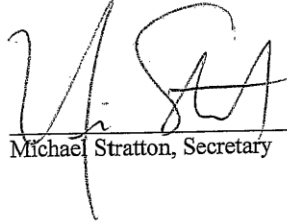

Michael Stratton, Secretary

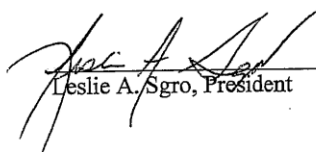

Leslie A. Sgro, President

ORDINANCE #1118-07
Project Labor Agreement (PLA)

WHEREAS, the Springfield Park District has a compelling interest in awarding public works contracts so as to ensure the highest standards of quality and efficiency at the lowest responsible cost; and

WHEREAS, a project labor agreement, which is a form of pre-hire collective bargaining agreement covering all terms and conditions of employment on a specific project, can ensure the highest standards of quality and efficiency at the lowest responsible cost on appropriate public works projects; and

WHEREAS, the Springfield Park District has a compelling interest that a highly skilled workforce be employed on public works projects to ensure lower costs over the lifetime of the completed project for repairs and maintenance; and

WHEREAS, project labor agreements provide the Springfield Park District with a guarantee that public works projects will be completed with highly skilled workers; and

WHEREAS, project labor agreements provide for peaceful, orderly, and mutually binding procedures for resolving labor issues without labor disruption; and

WHEREAS, project labor agreements allow public agencies to predict more accurately the actual cost of the public works project; and

WHEREAS, the use of project labor agreements can be of specific benefit to complex construction projects of large scope such as road construction and repair; and

WHEREAS, project labor agreements are useful from a cost, efficiency, quality, safety, and timeliness standpoint and in eliminating potential for friction by ensuring that work is performed by trade unions that have traditionally performed and have trade and geographic jurisdiction over the work performed; therefore

Be it Ordained by the Board of the Springfield Park District, as follows:

Section 1. Public Works Projects.

On a project-by-project basis, for those capital projects with an estimated cost in excess of thirty thousand dollars (\$30,000), the Springfield Park District shall include a project labor agreement requirement in the bid specifications unless it has been determined that a project labor agreement would not advance the District's interests of cost, efficiency, quality, safety, timeliness, skilled labor force, and labor stability and the District's policy to advance minority-owned and female-owned business.

Section 2. Negotiation of Project Labor Agreement.

Unless it has been determined that a project labor agreement is not appropriate for a particular public works project, the District shall either (i) in good faith negotiate a project labor agreement with labor organizations engaged in the construction industry that represent experienced and skilled construction workers or (ii) condition the award of a project manager or general contractor

upon a requirement that the manager or contractor negotiate in good faith a project labor agreement with labor organizations engaged in the construction industry and, if necessary, use the Department of Labor to reach a project labor agreement. The District may reserve the right to approve the negotiated project labor agreement.

Section 3. Contents of Project Labor Agreement.

A project labor agreement must:

1. Set forth effective, immediate, and mutually binding procedures for resolving jurisdictional disputes, labor disputes, and grievances arising before the completion of work;
2. Contain guarantees against strikes, lockouts, or other similar actions;
3. Standardize the terms and conditions of employment of labor on the public works project;
4. Permit flexibility in work scheduling and shift hours and times;
5. Ensure a reliable source of skilled and experienced labor;
6. Further public policy objectives as to improved employment opportunities for minorities, females, and the economically disadvantaged in the construction industry;
7. Permit contractors and subcontractors to retain a percentage of their current workforce in addition to labor referred through the signatory labor organizations;
8. Permit the selection of the lowest qualified responsible bidder, without regard to union or non-union status at other construction sites;
9. Be made binding on all contractors and subcontractors on the public works project through the inclusion of appropriate bid specifications in all relevant bid documents; and
10. Require all contractors and subcontractors on public works projects to sign the applicable master collective bargaining agreements with the labor organizations having jurisdiction over the type of work performed.

Section 4. Justification of Project Labor Agreement.

Any decision not to use a project labor agreement in connection with a public works project by the District shall be supported by a written, publicly disclosed finding by the District setting forth the justification for the non-use of the project labor agreement.

Section 5. Effective Date.

This Ordinance takes effect upon its passage by the Board of the Springfield Park District.

PASSED: September 18, 2007

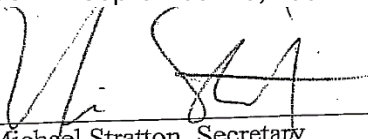

Michael Stratton, Secretary

APPROVED: Septmeber 18, 2007

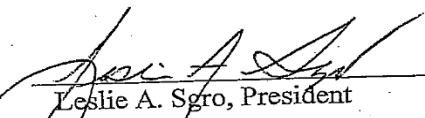

Leslie A. Sgro, President

BIDDING & CONTRACT REQUIREMENTS

Project Labor Agreement

SPRINGFIELD PARK DISTRICT

Standard Project Labor Agreement

Attached is the PROJECT LABOR AGREEMENT that the Contractor and Subcontractors will be required to sign

Project Labor Agreement

**SPRINGFIELD PARK DISTRICT
STANDARD PROJECT LABOR AGREEMENT**

This Agreement is entered into this ____ day of _____, _____, by and between the Springfield Park District (“District or Employer”) and the _____ **Project Labor Agreement Committee (PLA Committee)** for and on behalf of its affiliated members, individually and collectively. This agreement shall apply to work performed by the Employer and its Contractors and Subcontractors on construction projects known as the Springfield Park District Project No: _____ and described as:

ARTICLE I – INTENT AND PURPOSES

1.1 It is mutually understood that the following terms and conditions relating to employment of workmen covered by this Agreement have been written in order to promote efficiency of construction operations and provide for peaceful settlement of labor disputes without strikes or lockouts, thereby promoting the public interest in assuring the timely and economical completion of the work. It is also the intent of the parties to set out standard working conditions for the efficient prosecution of said construction work, herein to establish and maintain harmonious relations between all parties of the Agreement, to secure optimum productivity and to eliminate strikes, lockouts, or delays in the prosecution of the work.

(a) Therefore, the following provisions will be binding upon _____ Contractors and all its Subcontractors (hereinafter jointly referred to as “Contractor”), who shall be required to sign the “Participation Agreement”, attached hereto as “Schedule A”, and the Unions during the term of this Agreement and any renewal thereafter. The Unions hereby consent to apply the terms and conditions of the Project Labor Agreement to said Subcontractors upon their signing the “Participation Agreement”. It is understood that each Subcontractor will be considered and accepted by the Unions as a separate employer for the purposes of collective bargaining. It is further agreed that the employees working under this Agreement shall constitute a bargaining unit separate and distinct from all others. This Agreement may be modified by mutual consent in writing by the parties signatory hereto.

1.2 The Contractor agrees to be bound by the terms of the Collective Bargaining Agreements and amendments thereto of the affiliates of the PLA Committee and the applicable employers

association, if any. Such agreements are incorporated herein by reference. In order to comply with the requirements of the various fringe benefits funds to which the Contractor is to contribute, the Contractor shall sign such participation agreements as are necessary. Upon written notice from any fringe benefit fund the District will withhold payment of delinquencies occurring on this project from the involved Prime Contractors.

1.3 It is mutually understood that where the provisions of the Agreement are at variance with any other agreement between the Contractor and the Union, the language of this Agreement shall prevail.

1.4 The Contractor and the Union agree that should the Collective Bargaining Agreement (CBA) of any PLA Committee affiliates signatory to this Agreement expire prior to the completion of the project, the expired contract's terms will be maintained until a new CBA is ratified. The wages, and fringe benefits included in any new CBA will be effective on the effective date of the newly negotiated CBA unless wage and fringe benefit retroactivity is agreed upon by the bargaining parties.

ARTICLE II – RECOGNITION

2.1 The Contractor recognizes the PLA Committee and the signatory affiliates as the sole and exclusive bargaining representatives for its craft employees employed on the job site. PLA Committee affiliates signatory to the Agreement will have recognition on the project for their craft.

ARTICLE III – ADMINISTRATION OF AGREEMENT

3.1 In order to assure that all parties have a clear understanding of the Agreement, to promote harmony and address potential problems, a pre-job conference will be held with the Contractor, PLA Committee Representatives and all signatory parties prior to the start of any work on the project.

3.2 Representatives of the Contractor and the Unions shall meet as required but not less than once a month to review the operation of this Agreement. The representatives at this meeting shall be empowered to resolve any dispute over the intent and application of this Agreement.

3.3 The Contractor shall make available in writing to the Unions and Council no less than one week prior to these meetings a job status report, planned activities for the next 30 day period, actual members of craft employees on the project and estimated numbers of employees by craft required for the next 30 day period. The purpose of this report is to allow time to address any potential jurisdictional problems and to ensure that no party signatory to the Agreement is hindering the continuous progress of the project through a lack of planning or shortage of manpower.

ARTICLE IV – HOURS OF WORK, OVERTIME SHIFTS, & HOLIDAYS

4.1 The standard work day shall be an established consecutive eight (8) hour period between the hours of 7:00 a.m. and 5:00 p.m. with one-half hour designated as unpaid period for lunch. The standard work week shall be five (5) consecutive days of work commencing on Monday. Starting time which is to be established at the pre-job conference will be applicable to all craft employees on the project. Should job conditions dictate a change in the established starting time and/or a staggered lunch period on certain work of the project or with individual crafts, the Contractor, Business Managers of the crafts involved and the PLA Committee shall mutually agree to such changes. If work schedule change cannot be mutually agreed to between these parties, the hours fixed in the Agreement shall prevail.

4.2 All time before and after the established work day of eight (8) hours, Monday through Friday and all time on Saturday shall be paid in accordance with each crafts current collective bargaining agreement. All time on Sundays and Holidays shall be paid for at the rate of double time.

(a) Fringe benefit payments for all overtime work shall be paid in accordance with each craft's current collective bargaining agreement.

4.3 Shift work, if used, shall be as provided in the collective bargaining agreement of each affected craft.

4.4 Recognized Holidays shall be as follows: New Year's Day, Memorial Day, Fourth of July, Labor Day, Veterans Day (to be celebrated the day after Thanksgiving), Thanksgiving Day and Christmas Day. No work will be performed on Labor Day under any consideration, except in an extreme emergency and then only after consent is given by the Business Manager.

ARTICLE V – ABSENTEEISM

5.1 The Contractor and the Union agree that the chronic and/or unexcused absenteeism is undesirable and must be controlled. Employees that develop a record of such absenteeism shall be identified by the Contractor to the appropriate referral facility and the Contractor shall support such action with the work record of the involved employee. Any employee terminated for such absenteeism shall not be eligible for rehire on the project for a period of no less than ninety (90) days.

ARTICLE VI – MANAGEMENT RIGHTS

6.1 The Contractor retains and shall exercise full and exclusive authority and responsibility for the management of its operations, except as expressly limited by the terms of this Agreement and the Unions collective bargaining agreement.

ARTICLE VII – GENERAL WORKING CONDITIONS

7.1 Employment begins and ends at the project site, to be determined at the Pre-Job Conference.

7.2 Employees shall be at their place of work at the starting time and shall remain at their place of work until quitting time. The parties reaffirm their policy of a fair days work for a fair days pay.

7.3 The Contractor may utilize brassing, or other systems to check employees in and out. Should such procedures be required, the techniques and rules regarding such procedures shall be established by mutual consent of the parties at the pre-job conference.

7.4 There shall be no limit on production by workmen nor restrictions on the full use of tools or equipment. Craftsmen using tools shall perform any work of their trade and shall work under the direction of the craft foreman. There shall be no restrictions on efficient use of manpower other than as may be required by safety regulations.

7.5 Crew Foreman shall be utilized as per the existing collective bargaining agreements. The Contractor agrees to allow crew foremen ample time to direct and supervise the crew. The Union agrees there will be no restrictions placed on crew foreman's ability to handle tools and materials.

7.6 The Contractor may utilize the most efficient methods or techniques of construction, tools or other labor saving devices to accomplish the work. Practices not a part of the terms and conditions of this Agreement will not be recognized.

7.7 Should overtime work be required, the Contractor will have the right to assign specific employees and/or crews to perform such overtime work as is necessary to accomplish the work.

7.8 The Contractor may establish such reasonable project rules as the Contractor deems appropriate. These rules will be reviewed and established at the pre-job conference and posted at the project site by the Contractor.

7.9 It is recognized that specialized or unusual equipment may be installed on the project and in such cases, the Union recognizes the right of the Contractor to involve the equipment supplier or vendor's personnel in supervising the setting of the equipment, making modifications and final alignment which may be necessary prior to and during the start-up procedure, in order to protect factory warranties.

7.10 In order to promote a harmonious relationship between the equipment or vendor's personnel and the Building Trades craftsmen, a meeting shall be held between the Contractor and the Unions prior to any involvement on the project by these personnel. The Contractor will inform the Unions of the nature of involvement by these personnel and the numbers of personnel to be involved, allowing ample time for the Union representatives to inform their stewards prior to the start of any work.

ARTICLE VIII – SAFETY

8.1 The employees covered by the terms of this Agreement shall at all times while in the employ of the Contractor be bound by the safety rules and regulations by the Contractor in accordance with the Construction Safety Act and OSHA.

(a) These rules and regulations will be published and posted at conspicuous places throughout the project.

8.2 In accordance with the requirements of OSHA, it shall be the exclusive responsibility of each Contractor on a job site to which this Agreement applies, to assure safe working conditions for its employees and compliance by them with any safety rules contained herein or established by the Contractor. Nothing in this Agreement will make the District, PLA Committee or any of its affiliates liable to any employees or to other persons in the event that injury or accident occurs.

ARTICLE IX – SUBCONTRACTING

9.1 The Contractor agrees that neither he/she nor any of his subcontractors will subcontract any work to be done on the project except to a person, firm or corporation party signatory to this Agreement.

9.2 Any Contractor or Subcontractor working on the project covered by this Agreement shall as a condition to working on said project, become signatory to and perform all work under the terms of this Agreement. The furnishing of materials, supplies or equipment and the delivery thereof shall be considered subcontracting.

ARTICLE X – UNION REPRESENTATION

10.1 Authorized representatives of the PLA Committee and its signatory affiliates shall have access to the project provided they do not interfere with the work of the employees and further provided that such representatives fully comply with the visitor and security rules established for the project.

10.2 Each PLA Committee affiliate which is a party to this Agreement, shall have the right to designate a working journeyman as a steward. Such designated steward shall be a qualified worker performing the work of that craft and shall not exercise any supervisory functions. Each steward shall be concerned with the employees of the steward's employer and not with the employees of any other employer.

10.3 The working steward will be paid at the applicable wage rate for the job classification in which he/she is employed.

10.4 The working steward shall not be discriminated against because of his/her activities in performing his/her duties as steward, and except as otherwise provided in local agreements, shall

be the last employee in his/her craft to be laid off in any reduction in force. Stewards will be subject to discharge to the same extent that other employees are only after notification to the Union Representative. The Contractor will permit stewards sufficient time to perform the duties inherent to a steward's responsibilities. Stewards will be offered available overtime work if qualified.

ARTICLE XI – GRIEVANCE AND ARBITRATION PROCEDURES

11.1 It is specifically agreed that in the event any disputes arises out of the interpretation or application of the Agreement, excluding jurisdictional disputes which are covered by an expedited procedure in Article XII below, the same shall be settled by means of the procedure set out herein upon mutual agreement of the parties. Otherwise, the procedure set forth in the local collective bargaining agreement shall be used, but in no case shall both procedures be utilized to resolve such disputes. No such grievance shall be recognized unless called to the attention of the Contractor by the Union or to the Union by the Contractor within five (5) working days after the alleged violation was committed or discovered by the grieving party.

11.2 Grievances shall be settled according to the following procedure:

(a) Step 1. The dispute shall be referred to the Steward of the craft union involved and a representative of the Contractor at the construction project.

(b) Step 2. In the event that the steward and the Contractor's representative at the construction site cannot reach agreement within two (2) working days after a meeting is arranged and held, the matter shall be referred to the Union Business Manager, a representative of the PLA Committee and the Project Superintendent and/or Project Manager of the District.

(c) Step 3. In the event the dispute is not resolved within five (5) working days after completion of Step 2, these two shall request a panel of arbitrators from the U.S. Mediation and Conciliation Service for selection of an impartial arbitrator who shall hear the grievance and make a decision within ten (10) working days which shall be final and binding on all parties. The parties shall each pay the expense of their own representative. The decision of the arbitrator shall be binding upon all parties. The expense of the impartial arbitrator shall be borne equally by the Contractor and the involved craft Union.

ARTICLE XII – JURISDICTIONAL DISPUTES

This Agreement is entered into to prevent strikes, lost time, lockouts, and to facilitate the peaceful adjustment of jurisdictional disputes in the building and construction industry and to prevent waste and unnecessary avoidable delays and expense, and for the further purpose of at all times securing for the employer sufficient skilled workers.

12.1 All decisions of the Illinois Jurisdictional Dispute Resolution Process are final and binding upon all parties.

12.2 Administrative functions under the Illinois Jurisdictional Dispute Resolution Process shall be performed through the offices of the President and/or Secretary-Treasurer of the Illinois State Federation of Labor, or their designated representative.

12.3 The primary concern of the Illinois Jurisdictional Dispute Resolution Process shall be adjustment of jurisdictional disputes in the construction industry by independent Arbitrators selected by the Illinois State Federation of Labor. A sufficient number of Arbitrators shall be selected from geographical areas of the state of Illinois and shall be randomly assigned to a particular dispute subject only to the Arbitrator's ability to conduct a hearing and render a decision in a timely manner as required under this Process. Decisions shall be only for the specific job under consideration and shall become effective immediately upon issuance and complied with by all parties.

12.4 In rendering a decision, the Arbitrator shall determine:

(a) First, whether a previous agreement of record or applicable agreement, including a disclaimer agreement, between National or International Unions to the dispute or agreements between local unions involved in the dispute, governs;

(b) Only if the Arbitrator finds that the dispute is not covered by an appropriate or applicable agreement of record or agreement between the crafts to the dispute in the local area, the Arbitrator shall then consider whether there is a previous decision of record governing the case, including decisions of construction industry arbitration panels within the geographical jurisdiction of the local area Building Trades Council located within the State of Illinois;

(c) If the Arbitrator finds that a previous decision of record governs the case, the Arbitrator shall apply the decision of record in rendering his/her decision except under the following circumstances: After notice to the other parties to the dispute prior to the hearing that intends to challenge the decision of record, if a trade challenging the decision of record is able to demonstrate that the recognized and established prevailing practice in the locality of the work has been contrary to the applicable decision of record, and that historically in that locality the work in dispute has not been performed by the other craft or crafts, the Arbitrator may rely on such prevailing practice rather than the decision of record. If the craft relying on the decision of record demonstrates that it has performed the work in dispute in the locality of the job, then the Arbitrator shall apply the decision of record in rendering his/her decision. If the Arbitrator finds that a craft has improperly obtained the prevailing practice in the locality through raiding, the undercutting of wages, or the use of vertical

agreements, the Arbitrator shall rely on the decision of record than the prevailing practice in the locality;

(d) If no decision of record is applicable, the Arbitrator shall then consider the established trade practice in the industry and prevailing practice in the locality, and any party to the dispute may rely on prior decisions of record, decisions of construction industry arbitration panels within the state of Illinois.

(e) Only if none of the above criteria is found to exist, the Arbitrator shall then consider that because efficiency, cost or continuity and good management are essential to the well-being of the industry, the interests of the consumer or the past practices of the employer shall not be ignored.

12.5 The Arbitrator shall set forth the basis for his/her decision and shall explain his/her findings regarding the applicability of the above criteria. If lower ranked criteria are relied upon, the Arbitrator shall explain why the higher-ranked criteria were not deemed applicable. The Arbitrator's decision shall only apply to the job in dispute. Agreements of Record are applicable only to those parties signatory to such agreements. Decisions of Record are those that were either attested to by the former Impartial Jurisdictional Disputes Board or adopted by the National Arbitration Panel.

12.6 There shall be no abandonment of work during any case participating in the Process of in violation of the arbitration decision. All parties to the Process release the Illinois State Federation of Labor ("Federation") from any liability arising from its action or inaction and covenant not to sue the Federation.

12.7 In the event of a dispute relating to trade or work jurisdiction, all parties, including the employers, contractors or subcontractors, agree that a final and binding resolution of the dispute shall be resolved as follows:

(a) Representatives of the affected trades and the employer shall meet on the job site within forty-eight (48) hours after receiving notice in an effort to resolve the dispute. (In the event there is a dispute between local unions affiliated with the same International Union, the decision of the General President, or his/her designee, as the internal jurisdictional authority of the International Union, shall constitute a final and binding decision and determination as to the jurisdiction of the work.)

(b) If no settlement is achieved subsequent to the proceeding Paragraph, the matter shall be referred to the local area Building & Construction Trades Council, which shall meet with the affected trades within forty-eight (48) hours subsequent to receiving written notice. In the event the parties do not wish to avail themselves of the local Building & Construction Trades Council, the parties may elect

to invoke the services of their respective International Representatives with no extension of the time limitations. An agreement reached at this Step shall be final and binding upon all parties.

(c) If no settlement agreement is reached during the proceedings contemplated by Paragraphs “a” or “b” above, the matter shall be immediately referred to the Illinois Jurisdictional Dispute Board pursuant to the provisions of the Jurisdictional Dispute Resolution process, which may be amended from time to time, for final and binding resolution of said dispute. Said referral submission shall be in writing and served upon the Illinois State Federation of Labor, or its designated representative, pursuant to Article II of this agreement. The Administrator shall, within seventy-two (72) hours provide for the selection of an available Arbitrator to hear said dispute within this time period. Upon good cause shown to the Administrator, an additional seventy-two (72) hour extension for said hearing shall be granted at the sole discretion of the Administrator. Only upon mutual agreement of all parties may the Administrator extend the hearing for a period in excess of the time frames contemplated under this Paragraph. All time period contained in this Article specifically exclude Saturdays, Sundays and Holidays.

12.8 The Arbitrator chosen shall be randomly selected based on geographical location of the jurisdictional dispute and upon his/her availability to conduct a Hearing within forty-eight (48) hours of said notice. The Arbitrator may issue a “bench” decision immediately following the Hearing or he/she may elect to only issue a written decision, said decision must be issued within forty-eight (48) hours subsequent to the completion of the Hearing. Copies of all notices, pleadings, supporting memoranda, decisions, etc. shall be provided to all disputing parties, the local Building & Construction Trades Council, and the Illinois State Federation of Labor.

Any written decision shall be in accordance with this Process and shall be final and binding upon all parties to the dispute and may be a “short form” decision. Fees and costs of the Arbitrator shall be divided evenly between the contesting parties except that any party wishing a full opinion and decision beyond the short form decision shall bear the reasonable fees and costs of such full opinion.

In the event a jurisdictional dispute is not referred to the Illinois Jurisdictional Dispute Resolution Process by either (or any) of the labor organizations claiming the work, the employer may, upon its own initiative, or at the request of the Illinois Capital Development Board, petition the Administrator to assign an Arbitrator to hear the case. The decision of the Arbitrator shall be final and binding upon the parties hereto, their members, and affiliates.

In cases of jurisdictional disputes or other disputes between a signatory labor organization and another labor organization, both of which is an affiliate or member of the same International Union, the matter or dispute shall be settled in the manner set forth by their International Constitution and/or as determined by the International Union's General President whose decision shall be final and binding upon all parties. In no event shall there be an abandonment of work.

12.9 All interested parties shall be entitled to make presentations to the Arbitrator. Any interested party present at the Hearing, whether making a presentation or not, by such presence shall be deemed to accept the jurisdiction of the Arbitrator and to agree to be bound by its decision. In addition to the representative of the local labor organization, a representative of the local labor organization's International Union may appear on behalf of the parties. Each party is responsible for arranging for its witnesses. In the event an Arbitrator's subpoena is required, the party requiring said subpoena shall prepare the subpoena for the Arbitrator to execute. Service of the subpoena upon any witness shall be the responsibility of the issuing party.

Upon approval of the Arbitrator, other parties not directly involved in the dispute may be invited to be present during the presentation and discussion. Attorneys shall not be permitted to attend or participate in any portion of a Hearing.

The parties are encouraged to determine, prior to Hearing, documentary evidence which may be presented to the Arbitrator on a joint basis.

12.10 The Order of Presentation in all Hearings before an Arbitrator shall be:

- I. Identification and Stipulation of the Parties
- II. Union(s) claiming the disputed work presents its case
- III. Unions assigned the disputed work presents its case
- IV. Employer assigning the disputed work presents its case
- V. Evidence from other interested parties (i.e., general contractor, project manager, owner, etc.)
- VI. Rebuttal by union(s) claiming the disputed work
- VII. Additional submissions permitted and requested by Arbitrator
- VIII. Closing arguments by the parties

12.11 To further the interests of the Illinois Jurisdictional Dispute Resolution Process, it is agreed that any party hereto or any employer may at any time file a Verified Complaint in writing with the Administrator alleging a violation of a decision or award previously made by the Arbitrator. The Administrator shall thereupon set a subsequent Hearing, before the same Arbitrator who presided

at the initial Hearing or the next available Arbitrator in the event the original Arbitrator cannot timely hear the Verified Complaint. Said Hearing shall be held within three (3) days of receipt of the Verified Complaint with respect to the alleged violation. The Administrator shall notify all interested parties of the time and place of the Hearing; provided, however, that the party filing the Verified Complaint must have served a copy of said document and all supporting documents to all interested parties and the Administrator.

All parties shall be given an opportunity to testify and present documentary evidence relating to the subject matter of the Hearing. Within forty-eight (48) hours after the conclusion of the Verified Complaint, the Arbitrator shall render a written decision in the matter and shall state whether or not there has been a violation of the Arbitrator's prior decision or award. Copies of the decision shall be served by regular mail, personal service or facsimile.

Should the Arbitrator determine that there has been a violation of its prior decision or award, it shall order immediate compliance by the offending party(s). The Arbitrator may take one more of the following courses of action in order to enforce compliance with its decision:

(a) Assess liquidated damages not to exceed \$_____ for each violation by the members of, or employees represented by, the parties hereto, and may assess liquidated damages not to exceed \$_____ for each violation by either party hereto or any of its offices or representatives. If a fine is rendered by the Arbitrator, it should be commensurate with the seriousness of the violation having a relationship to lost hours for the labor organizations and lost efficiency for the employer. Each of the parties hereto hereby agrees for itself and its members to pay to the other party said liquidated damages within thirty (30) days from any sum, or sums, so assessed because of violations of a decision or award by itself, its officers or representatives, or its member(s). Should either party bound to this Process, or any of its members fail to pay the amount so assessed within the thirty (30) day time period herein provided, the party or member so failing to pay shall be deprived of all the benefits of this Process until such time as the matter is adjusted to the satisfaction of the Administrator; provided, however, the foregoing shall not prohibit the offending party from defending jurisdictional dispute claim in a subsequent, non-related matter.

(b) In the event the Arbitrator determines that there is a violation of this Section, the Arbitrator may order an immediate cessation of all work by the non-compliant employers and employees performing work on the project. Enforcement of any decision of an Arbitrator or finding of non-compliance, including remedies contemplated under this Section, shall be pursuant to the terms and conditions of Section 12.12.

The filing of a Verified Complaint is not a necessary requirement in order for a party to seek judicial enforcement of the Arbitrator's prior decision or award.

12.12 The Illinois Jurisdictional Dispute Resolution Process, as an arbitration panel, not its Administrator, shall have any authority to undertake any action to enforce its decision(s). Rather, it shall be the responsibility of the prevailing party to seek appropriate enforcement of a decision, including findings, orders or awards of the Arbitrator or Administrator determining non-compliance with a prior award or decision. The prevailing party in any enforcement proceedings shall be entitled to recover its costs and attorneys fees from the non-prevailing party. In the event the Illinois Jurisdictional Dispute Resolution Process or its Administrator is made a party to, or is otherwise required to participate in any such enforcement proceedings for whatsoever reason, the non-prevailing party shall bear all costs, attorneys' fees, and any other expenses incurred by the Process or the Administrator in those proceedings.

12.13 In the event there is a question as to the jurisdiction of the Illinois Jurisdictional Dispute Resolution Process, the primary responsibility for any determination of the arbitrability of a dispute and the jurisdiction of the Arbitrator shall be borne by the party requesting the Arbitrator to hear the underlying jurisdictional dispute. The affected party or parties may proceed before the Arbitrator even in the absence or one or more stipulated parties with the issue of jurisdiction as an additional item to be decided by the Arbitrator. The Administrator may participate in proceedings seeking a declaration or determination that the underlying dispute is subject to the jurisdiction and process of the Illinois Jurisdictional Dispute Resolution Process. In any such proceedings, the non-prevailing party and/or the party challenging the jurisdiction of the Illinois Jurisdictional Dispute Resolution Process shall bear all the costs, expenses and attorneys fees incurred by the Illinois Jurisdictional Dispute Resolution Process and/or its Administrator in establishing its jurisdiction.

12.14 All parties bound to the provisions of this Process hereby release the Illinois State Federation of Labor and the Illinois Capital Development Board, their respective officers, agents, employees or designated representatives, specifically including any Arbitrator participating in said Process, from any and all liability or claim, of whatsoever nature, and specifically incorporating the protections provided in the Illinois Arbitration Act, as amended from time to time.

ARTICLE XIII – WORK STOPPAGES AND LOCKOUTS

13.1 During the term of this Agreement there shall be no strikes, picketing, work stoppages, slow downs or other disruptive activity for any reason by the PLA Committee, its affiliates or by any

employee and there shall be no lockout by the Contractor. Failure of any Union or employee to cross any picket line established at the project site is a violation of this Article.

13.2 The PLA Committee and its affiliates shall not sanction, aid or abet, encourage or continue any work stoppage, picketing or other disruptive activity and will not make any attempt of any kind to dissuade others from making deliveries to or performing services for or otherwise doing business with the Contractor at the project site. Should any of these prohibited activities occur the Union will take necessary action to end such prohibited activities.

13.3 No employee shall engage in any activities which violate this Article. Any employee who participates in or encourages any activities which interfere with the normal operation of the project shall be subject to disciplinary action, including discharge, and if justifiably discharged for the above reasons, shall not be eligible for rehire on the same project for a period of not less than ninety (90) days.

13.4 Neither the PLA Committee or its affiliates, shall be liable for acts of employees for which it has not responsibility. The principal officer or officers of the PLA Committee will immediately instruct, order and use the best efforts of his/her office to cause the affiliated union or unions to cease any violations of this Article. The PLA Committee in its compliance with this obligation shall not be liable for unauthorized acts of its affiliates. The principal officer or officers of any involved affiliate will immediately instruct, order or use the best effort of his/her office to cause the employees the union represents to cease any violations of this Article. A union complying with this obligation shall not be liable for unauthorized acts of employees it represents. The failure of the Contractor to exercise its right in any instance shall not be deemed a waiver of its right in any other instance.

13.5 In lieu of any action at law or equity, any party shall institute the following procedure when a breach of this Article is alleged, after all involved parties have been notified of the fact.

(a) The party invoking this procedure shall notify an individual to be mutually agreed upon, whom the parties agree shall be the permanent Arbitrator under this procedure. In the event the permanent Arbitrator is unavailable at any time, he/she shall appoint his/her alternate. Notice to the Arbitrator shall be by the most expeditious means available, with notice by telegram or any effective written means to the party alleged to be in violation and all involved parties.

(b) Upon receipt of said notice the Arbitrator named above shall set and hold a hearing within twenty-four (24) hours it is contended the violation still exists but not before twenty-four (24) hours after the telegraph notice to all parties involved as required above.

(c) The Arbitrator shall notify the parties by telegram or any other effective written means, of the place and time he/she has chosen for this hearing. Said hearing shall be completed in one session. A failure of any party or parties to attend said hearing shall not delay the hearing of evidence or issuance of an Award by the Arbitrator.

(d) The sole issue at the hearing shall be whether or not a violation of this Article has in fact occurred. The Award shall be issued in writing within three (3) hours after the close of the hearing, and may be issued without an Opinion. If any party desires an Opinion, one shall be issued within fifteen (15) days, but its issuance shall not delay compliance with, or enforcement of, the Award. The Arbitrator may order cessation of the violation of this Article, and such Award shall be served on all parties by hand or registered mail upon issuance.

(e) Such Award may be enforced by any court of competent jurisdiction upon the filing of the Agreement and all other relevant documents referred to herein above in the following manner. Telegraphic notice of the filing of such enforcement proceedings shall be given to the other party. In the proceeding to obtain a temporary order enforcing the Arbitrator's Award as issued under Section 13.5 of this Article, all parties waive the right to a hearing and agree that such proceedings may be ex parte. Such agreement does not waive any party's right to participate in a hearing for a final order of enforcement. The Court's order or orders enforcing the Arbitrator's Award shall be served on all parties by hand or by delivery to their last known address or by registered mail.

(f) Any rights created by statute or law governing arbitration proceedings inconsistent with the above procedure or which interfere with compliance therewith are hereby waived by parties to whom they accrue.

(g) The fees and expenses of the Arbitrator shall be borne by the party or parties found in violation, or in the event no violation is found, such fees and expenses shall be borne by the moving party.

ARTICLE XIV – GENERAL SAVINGS CLAUSE

14.1 If any Article or provision of this Agreement shall be declared invalid, inoperative or unenforceable by operation of law or by any of the above mentioned tribunals of competent jurisdiction, the remainder of this Agreement or the application of this Article or provision to persons or circumstances other than those as to which it has been held invalid, inoperative or unenforceable shall not be affected thereby.

ARTICLE XV – TERM OF AGREEMENT

15.1 This Agreement shall be in full force as of and from the date of the Notice of Award to the Substantial Completion of all applicable contractors.

Executed this _____(day) of _____ (month), 20____ (yr), in the City of Springfield, Illinois.

The Springfield Park District

By: _____

Director of Parks and Planning

By the following signature the General Contractor, _____,

agrees to be bound to the attached Project Labor Agreement negotiated between the Springfield Park District and the PLA Committee.

By: _____

Its: _____

Project Labor Agreement Committee

Union: _____

By: _____

Title: _____

Date: _____

Union: _____

By: _____

Title: _____

Date: _____

Union: _____

By: _____

Title: _____

Date: _____

Union: _____

By: _____

Title: _____

Date: _____

Union: _____

By: _____

Title: _____

Date: _____

Union: _____

By: _____

Title: _____

Date: _____

Union: _____

By: _____

Title: _____

Date: _____

Union: _____

By: _____

Title: _____

Date: _____

Union: _____

By: _____

Title: _____

Date: _____

Union: _____

By: _____

Title: _____

Date: _____

SCHEDULE A
PARTICIPATION AGREEMENT

The undersigned, a Subcontractor to _____,

(General Contractor)

agrees to be bound to the attached Project Labor Agreement negotiated between the Springfield Park District and the Project Labor Agreement Committee.

(Subcontractor)

By: _____

Date: _____

(Subcontractor)

By: _____

Date: _____

(Subcontractor)

By: _____

Date: _____

(Subcontractor)

By: _____

Date: _____

(Subcontractor)

By: _____

Date: _____

(Subcontractor)

By: _____

Date: _____

Springfield Park District

ORDINANCE #1161-08

SUBSTANCE ABUSE PREVENTION IN PUBLIC WORKS PROJECTS

In order to comply with the terms of the Substance Abuse Prevention in Public Works Projects Act, Public Act 095-0635, the following ordinance is hereby adopted, effective immediately. To the extent that this ordinance is inconsistent with any other drug and alcohol ordinance of this employer dealing with contractors who contract with the Park District, this policy shall prevail, in so far as any work done or to be done on any public works project. To the extent that this policy is inconsistent with a collective bargaining agreement that this employer has with any labor organization that addresses the same subject matter, such labor agreement shall prevail in accordance with the Act.

Section 1. Definitions. As used in this Policy:

"Accident" means an incident caused, contributed to, or otherwise involving an employee that resulted in death, personal injury, or property damage and that occurred while the employee was performing work on a public works project.

"Alcohol" means any substance containing any form of alcohol including, but not limited to, ethanol, methanol, propanol, and isopropanol.

"Alcohol concentration" means: (1) the number of grams of alcohol per 210 liters of breath; or (2) the number of grams of alcohol per 100 milliliters of blood.

"Drug" means a controlled substance as defined in the Illinois Controlled Substances Act or cannabis as defined in the Cannabis Control Act for which testing is required by an employer under its substance abuse prevention program under this policy. The term "drug" includes prescribed medications not used in accordance with a valid prescription.

"Employee" means a laborer, mechanic, or other worker employed in any public works by anyone under a contract for public works.

"Employer" means a contractor or subcontractor performing a public works project.

"Public works" and "public body" have the meanings ascribed to those terms in the Prevailing Wage Act.

Section 2. Substance abuse prohibited. No employee may use, possess, distribute, deliver, or be under the influence of a drug, or use or be under the influence of alcohol, while performing work on a public works project for the Park District. An employee is considered to be under the influence of alcohol for purposes of this policy if the alcohol concentration in his or her blood or breath at the time alleged as shown by analysis of the employee's blood or breath is at or above 0.02.

Section 3. Substance abuse prevention programs required.

(1) Before an employer commences work on a public works project for the Park District, the employer shall have in place a written program which meets or exceeds the program requirements in this Act, to be filed with the District and made available to the general public, for the prevention of substance abuse among its employees. The testing must be performed by a laboratory that is certified for Federal Workplace Drug Testing Programs by the Substance Abuse and Mental Health Service Administration of the U.S. Department of Health and Human Services. At a minimum, the program shall include all of the following:

(A) A minimum requirement of a 9 panel urine drug test plus a test for alcohol. Testing an employee's blood may only be used for post-accident testing, however, blood testing is not mandatory for the employer where a urine test is sufficient.

(B) A prohibition against the actions or conditions specified in Section 2.

(C) A requirement that employees performing the work on a public works project submit to pre-hire, random, reasonable suspicion, and post-accident drug and alcohol testing. Testing of an employee before commencing work on a public works project is not required if the employee has been participating in a random testing program during the 90 days preceding the date on which the employee commenced work on the public works project.

(D) A procedure for notifying an employee who violates Section 2, who tests positive for the presence of a drug in his or her system, or who refuses to submit to drug or alcohol testing as required under the program that the employee may not perform work on a public works project until the employee meets the conditions specified in subdivisions (2)(A) and (2)(B) of Section 3.

(2) Reasonable suspicion testing. An employee whose supervisor has reasonable suspicion to believe the employee is under the influence of alcohol or a drug is subject to discipline up to and including suspension, and be required to undergo an alcohol or drug test. "Reasonable suspicion" means a belief, based on behavioral observations or other evidence, sufficient to lead a prudent or reasonable person to suspect an employee is under the influence and exhibits slurred speech, erratic behavior, decreased motor skills, or other such traits. Circumstances, both physical and psychological, shall be given consideration. Whenever possible before an employee is required to submit to testing based on reasonable suspicion, the employee shall be observed by more than one supervisory or managerial employee. It is encouraged that observation of an employee should be performed by a supervisory or managerial employee who has successfully completed a certified training program to recognize drug and alcohol abuse. The employer who is requiring an employee to be tested based upon reasonable suspicion shall provide transportation for the employee to the testing facility and may send a representative to accompany the employee to the testing facility. Under no circumstances may an employee thought to be under the influence of alcohol or a drug be allowed to operate a vehicle or other equipment for any purpose. The employee shall be removed from the job site and placed on inactive status pending the employer's receipt of notice of the test results. The employee shall have the right to request a representative or designee to be present at the time he or she is directed to provide a specimen for testing based upon reasonable suspicion. If the test result is positive for drugs or alcohol, the employee shall be subject to termination. The employer shall pay all costs related to this testing. If the test result is negative, the employee shall be placed on active status and shall be put back to work by

the employer. The employee shall be paid for all lost time to include all time needed to complete the drug or alcohol test and any and all overtime according to the employee's contract.

(3) An employer is responsible for the cost of developing, implementing, and enforcing its substance abuse prevention program, including the cost of drug and alcohol testing of its employees under the program, except when these costs are covered under provisions in a collective bargaining agreement. The testing must be performed by a laboratory that is certified for Federal Workplace Drug Testing Programs by the Substance Abuse and Mental Health Service Administration of the U.S. Department of Health and Human Services. The contracting agency is not responsible for that cost, for the cost of any medical review of a test result, or for any rehabilitation provided to an employee.

Section 4. Employee access to project.

(1) An employer may not permit an employee who violates Section 2, who tests positive for the presence of a drug in his or her system, or who refuses to submit to drug or alcohol testing as required under the employer's substance abuse prevention program under Section 3 to perform work on a public works project for the District until the employee meets the conditions specified in subdivisions (2)(A) and (2)(B). An employer shall immediately remove an employee from work on a public works project if any of the following occurs:

(A) The employee violates Section 2, tests positive for the presence of a drug in his or her system, or refuses to submit to drug or alcohol testing as required under the employer's substance abuse prevention program.

(B) An officer or employee of the Park District, preferably one trained to recognize drug and alcohol abuse, has a reasonable suspicion that the employee is in violation of Section 2 and requests the employer to immediately remove the employee from work on the public works project for reasonable suspicion testing.

(2) An employee who is barred or removed from work on a public works project under subsection (1) may commence or return to work on the public works project upon his or her employer providing to the contracting agency documentation showing all of the following:

(A) That the employee has tested negative for the presence of drugs in his or her system and is not under the influence of alcohol as described in Section 2.

(B) That the employee has been approved to commence or return to work on the public works project in accordance with the employer's substance abuse prevention program.

(C) Testing for the presence of drugs or alcohol in an employee's system and the handling of test specimens was conducted in accordance with guidelines for laboratory testing procedures and chain-of-custody procedures established by the Substance Abuse and Mental Health Service Administration of the U.S. Department of Health and Human Services.

(3) Upon successfully completing a rehabilitation program, an employee shall be reinstated to his or her former employment status if work for which he or she is qualified exists.

Section 5. Applicability. This Act applies to a contract to perform work on a public works project for which bids are opened on or after January 1, 2008, or, if bids are not solicited for the contract, to a contract to perform such

work entered into on or after January 1, 2008. The provisions of this Act apply only to the extent there is no collective bargaining agreement in effect dealing with the subject matter of this Act.

Section 6. The Park District reserves the right to reject any bid for any public works project of the District submitted by any contractor that does not have the policies and programs required by the Act and this ordinance, or a collective bargaining agreement covering the same subject matter, in effect at the time of the submission of its bid for the public works project, or at the time work on the project is to be commenced. If, at the time a public works project of the District is to be commenced, the contractor does not have the policies and programs in place as required by the Act and this ordinance, the Park District may elect to terminate the contract with such contractor.

Section 7. Effective date. This Act takes effect from and after its passage according to law.

Passed: February 20, 2008

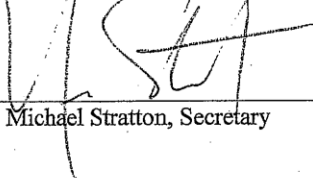

Michael Stratton, Secretary

Approved: February 20, 2008

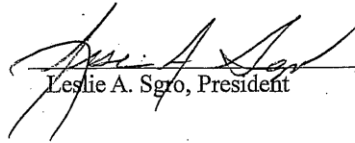

Leslie A. Sgro, President

INSTRUCTIONS TO BIDDERS

EXAMINATION OF SITE

Bidder shall examine the site and all conditions thereon. Proposal shall consider all conditions that may affect contract work. No additional expenses will be allowed for failure to be so informed.

DISCREPANCIES

Should bidder find during examination of specifications or drawings or after visit to site, discrepancies, omissions, ambiguities, or conflicts about Contract documents. Or being in doubt as to their meaning, he/she should notify the Consultant or the Springfield Park District not later than three (3) days prior to the due date of the bid. If required, an addendum will be issued to all prospective bidders a minimum of one (1) day before bid opening.

WITHDRAWAL OF BIDS

Bids may be withdrawn at any time prior to scheduled time for opening of the bids. NO BIDDER may withdraw his/her bid for a period of thirty (30) days after the bid date.

BID REQUIREMENTS

A detailed Bid Proposal has been provided. Bids will be received for the total cost of the contract. The total cost of the contract shall be obtained by taking the product of the quantity for a bid item multiplied by the unit price per item and then adding the resultant products. The Contractor shall furnish all equipment, tools, labor, materials, and incidentals and shall include the cost of these items in the unit price for the work. The quantities appearing in the bid proposal are estimates prepared for the establishment of pay item prices and the comparison of bids. Payment to the Contractor will be made on a unit basis in accordance with this bid proposal for the actual measured quantities performed and accepted or material furnished and accepted or material furnished and accepted according to the contract, and the scheduled quantities may be increased, decreased, or omitted as herein provided.

Contractor must qualify as to his/her competency in the trade he/she is bidding prior to receiving a set of contract documents. He/She must be willing to cooperate with the Owner if asked for additional information to determine his/her qualifications.

Contractor, after award of work, shall provide a performance bond in the amount of one hundred percent (100%) of the amount of his/her bid awarded.

TIME OF COMPLETION

All work shall be completed 38 weeks from the start date of an executed Notice to Proceed. Failure to complete this work by these dates will result in liquidated damages as provided within this document.

REJECTION OF BIDS

The owner, Springfield Park District, reserves the right to reject any or all bids and to waive any technicalities in the bids.

No bid may be withdrawn for a period of thirty (30) days after the opening of bids without the consent of the District. The failure to submit a cashier's check, certified check or bid bond in the full amount to cover the proposals being bid upon shall be enough cause for rejection of the bid.

BID FORM

Proposal must be made on the bid form provided and delivered to the address stated in the advertisement for bids before 2:00 p.m. CT on 01-Nov-24 at which time bids will be opened publicly.

Oral, telephone or telegraphic proposals will not be considered.

PRE-BID MEETING

A non-mandatory Pre-Bid Meeting will be held at 1:00 p.m. CT on 24-Oct-24. The meeting will be held at Nelson Center Ice Rink located at 1601 N 5th St., Springfield, IL 62702.

Springfield Park District
Summary of Quantities

Description	Amount
Demolition	
Refrigeration Plant – Mechanical	
Refrigeration Plant – Automation	
Rink Floor System – Mechanical	
Rink Floor System – General	
Dasher Board System – New	
Dasher Board System – Reinstallation	
General Mechanical	
General Electrical	
Fluid Cooler Stand and Housekeeping Pads	
IT Infrastructure Cash Allowance	\$5,000.00
Construction Total	

Submitted By: _____
Contractor

Authorized Signature

BID FORM

BID TO: SPRINGFIELD PARK DISTRICT
BID FROM: _____
(BIDDER'S NAME)

(BIDDER'S ADDRESS)

A. THE UNDERSIGNED

1. Acknowledges receipt of:

a. Project Manual for: SPRINGFIELD PARK DISTRICT
Springfield Rink Floors and Plant Replacement
SPRINGFIELD, IL

b. Drawings: Included in the Project Manual

c. Addenda: No. _____ Dated _____
No. _____ Dated _____
No. _____ Dated _____
No. _____ Dated _____

2. Has examined the sites and all Bidding Documents. He/She shall be responsible for performing all work specifically required of him/her by all parts of the Bidding Documents, including all Drawings and Specifications for the entire projects even though such work may be included as related requirements specified in other divisions or sections.

3. Agrees to:

a. Hold this Bid open until 30 calendar days after Bid Opening Date.

b. Accept the provision regarding disposition of bid security.

c. Enter into and execute a Contract with The Springfield Park District, when awarded on the basis of this Bid, and in connection therewith to:

- i. Furnish all bonds and insurance in accord with the Bidding Documents
- ii. Accomplish the work in accord with the Contract
- iii. Complete the work by the specified completion date

B. CONTRACT TIME SPECIAL NOTE – DEADLINE FOR COMPLETION

Contractor shall commence work upon receipt of an executed “Start After” date and shall complete all work 38 weeks from the start date of an executed Notice to Proceed.

C. THE UNDERSIGNED PROPOSES and AGREES AS FOLLOWS:

ITEM Proposed **BASE BID** contract amount:

The undersigned PROPOSES to furnish all labor, materials, and equipment required in connection with the construction of the above referenced project, in accordance with the Project Manual, Specifications, Drawings and any Addenda as hereinafter listed, for the TOTAL COST OF THE CONTRACT OF \$ _____. Total Cost of the Contract shall be the sum of the resultant products obtained by multiplying the quantity of a bid item by the respective unit bid price provided on the Summary of Quantities. Payment will be based on actual quantities performed at the unit price on the Bid Proposal.

1. Completion:

The undersigned AGREES to complete all required work of the contract as stated in Time of Completion.

2. Bidding Documents:

This proposal is in all respects based upon the following documents, all as issued for bidding purposes by The Springfield Park District,

a. Specifications:

Project Manual

Specifications included in the Project Manual and outlined by the document:
“24-009 Springfield Plant Replacement Tender Specification v2.0”

b. Drawings Included in the Project Manual and outlined as:

“24-009 PKG01 SPD – Detailed Design Package v4.0”

If bidder is:
AN INDIVIDUAL

BY _____ (Seal)
(Individual's Name)

Doing Business as _____ (Seal)
Business Address _____
Phone Number _____

A PARTNERSHIP

BY _____ (Seal)
(Firm Name)

(General Partner)

Business Address _____
Phone Number _____

A CORPORATION

BY _____ (Seal)
(Corporation Name)

(State of Incorporation)

BY _____
(Name and Title of Person Authorized to Sign)

(Corporate Seal)

Attest _____

A JOINT VENTURE

BY _____
(Name)

Business Address _____

BY _____
(Name of Person Authorized to sign)

SPRINGFIELD RINK FLOORS AND PLANT REPLACEMENT
SPRINGFIELD PARK DISTRICT
2500 South 11th Street, Springfield IL 62703

OTHER CONDITIONS, PROVISIONS OF REQUESTED INFORMATION

**CONTRACTOR QUALIFICATIONS
PREVIOUS SIMILAR PROJECTS**

Please provide a list of some projects successfully completed by your firm in the last five years. Include in this information the Owner's name, address, phone number and contact person.

Project Name	Contact	Phone #	Completion Date
_____	_____	_____	_____
_____	_____	_____	_____
_____	_____	_____	_____

PREVAILING WAGE SCHEDULE

Pursuant to P.A. 100-1177: Attached is the current Schedule of Prevailing Wage Rates.

<https://labor.illinois.gov/laws-rules/conmed/current-prevailing-rates.html>

“PUBLIC CONTRACT CERTIFICATION: The undersigned Contractor does hereby certify that the Contractor is not barred from contracting with any unit of state or local government as a result of violation of either Section 5/33 E-3 (Bid-rigging) or Section 5/33 E-4 (Bid-rotating) of the Illinois Criminal Code of 1961, as amended (720 ILCS 5/33 E-3 and 720 ILCS 5/33 E-4). This certification is made pursuant to section 5/33 E-11 of the Illinois Criminal Code of 1961, as amended (720 ILCS 5/33 E-11).

Date _____ Signed _____

Firm/Title _____

BID BOND

KNOW ALL MEN BY THESE PRESENTS, that we the undersigned, _____
as
PRINCIPAL, AND _____, as SURETY are held and firmly bound unto
the Springfield Park District, hereinafter called the Grantee/Local Public Agency in the
penal sum of _____ Dollars, (\$_____), lawful money in the United States, for the
payment of which sum well and truly to be made, we bind ourselves, our heirs, executors,
administrators, successors, and assigns, jointly and severally, firmly by these presents.

THE CONDITION OF THIS OBLIGATION IS SUCH, that Whereas the Principal has
submitted the Accompanying Bid, dated _____, _____ yr, for the
Springfield Rink Floors and Plant Replacement.

NOW, THEREFORE, if the Principal shall not withdraw said Bid within the period specified
therein after opening the same, or, if no period be specified, within thirty (30) days after the
said opening, and shall within the period specified therefore, or if no period specified,
within ten (10) days after the prescribed forms are presented to him for signature, enter
into a written Contract with the Grantee/Local Public Agency in accordance with the Bid as
accepted, and give bond with good and sufficient surety or sureties, as may be required,
for the faithful performance and proper fulfillment of such contract; or in the event of the
withdrawal of said Bid within the period specified, or the failure to enter into such Contract
and give such bond within the time specified, if the Principal shall pay the Grantee/Local
Public Agency the difference between the amount specified in said Bid and the amount for
which the Grantee/Local Public Agency may procure the required work or supplies or both,
if the latter be in excess of the former, then the above obligation shall be void and of no
effect, otherwise to remain in full force and virtue.

IN WITNESS WHEREOF, the above-bounded parties have executed this instrument under
their several seals this _____ day of _____, _____yr, the name and corporate
seal of each corporate party being hereto affixed and these present signed by its
undersigned representative, pursuant to authority of its governing body.

1. Forms of Bid Bonds prepared to meet the requirements of local or State laws or the
needs of the Grantee/Local Public Agency should be substituted for this form where
necessary.

_____ (SEAL)

_____ (SEAL)

Attest:

By: _____

Attest:

By: _____

By: _____

Countersigned by _____

2. Attorney-in-Fact, State of _____

CERTIFICATE AS TO CORPORATE PRINCIPAL

I, _____, certify that I am the _____,
_____, Secretary of the Corporation named as the Principal in the
within bond; that _____, who signed the bond on behalf of the Principal was
then _____, of said corporation; that I know his signature, and
his signature thereto is genuine; and that said bond was duly signed, sealed, and attested
to for and in behalf of said corporation by authority of this governing body.

Title _____

Power-of-attorney for person signing for surety company must be attached to bond.

SPECIAL PROVISIONS

PRE-CONSTRUCTION MEETING

The Contractor shall schedule a meeting with the Springfield Park District prior to beginning any work. The purpose of this meeting is to discuss the project schedule and any other items which may be necessary. The Springfield Park District should be notified at least 24 hours prior to any construction operations taking place.

CONTRACTOR'S RESPONSIBILITY FOR SAFETY

The Contractor shall do all work necessary for safety and be solely and completely responsible for conditions on the jobsite, including safety of all persons and property during the contract period. This requirement shall apply continuously and not be limited to normal working hours.

PROTECTION OF PUBLIC PROPERTY

The Contractor shall employ such means and methods as necessary to adequately protect public property of the Owner against damage. In the event of damage to such property, the Contractor shall, at his own expense, immediately restore the property to a condition equal to its original condition and to the satisfaction of the Consultant and the owner of said property.

RESTORATION OF EXISTING FACILITIES AND CLEANUP

Any item, such as sidewalks, mailboxes, gate posts and gates, signs, fences, shrubbery, etc., not shown to be removed on the Plans, which is damaged by the Contractor, shall be replaced at his/her own expense.

The cost of cleanup operations shall be included in the Contractor's bid. Cleanup shall consist of removing all debris from the job site, to include removal of all excess concrete, pipe pieces, lumber scraps, paper cups, etc., left by the Contractor. Initial cleanup shall be performed before moving forces to the next portion of the job, and a final cleanup will be done after all operations have been completed.

BID GUARANTEE

A cashier's check or Bid bond, payable to Springfield Park District (Owner) in an amount equal to ten percent (10%) of the Contractor's total bid price as a proposal guarantee, shall accompany each bid.

PERFORMANCE BOND & PAYMENT BOND

A performance and payment bond for one hundred percent (100%) of the awarded contract price shall be presented to the Springfield Park District prior to construction.

PREQUALIFICATION OF BIDDER

Prior to receiving a proposal for bidding, the interested bidder shall submit to the Owner a list of similar projects for which he/she had total responsibility for the construction thereof. Owner shall consider, but not be limited to, the following items: Integrity, professional abilities, workmanship, the present condition of previously constructed facilities, usage and care of facility and such other investigations as it may deem necessary to satisfy itself of the bidder’s ability to perform under contract. The prequalification of the bidder shall not prejudice the Owner’s right to accept or reject any of all bids.

LIQUIDATED DAMAGES

It is understood and agreed that TIME is of the essence on this Contract, and that a failure on the part of the Contractor to substantially complete all of the work under this Contract 38 weeks from the start date of an executed Notice to Proceed will result in loss and damage to the Owner; and that on account of the peculiar nature of such loss or damage, it is difficult, if not impossible, to accurately ascertain and definitely determine the amount thereof. It is therefore, covenanted and agreed that in case the Contractor shall fail or neglect to substantially complete all of the work herein specified, together with any extensions of time which may be granted, the said Contractor shall and will pay to the Owner for each and every calendar day the Contractor is in default in the time of completion of this contract the sum set forth below:

<u>Original Contract Amount</u>		
From More Than	To and Including	Amount of Liquidated Damages per Calendar Day
\$0	\$25,000	\$300
25,000	50,000	375
50,000	100,000	450
100,000	500,000	550
500,000	1,000,000	725
1,000,000	2,000,000	900

The above sum is hereby agreed upon, fixed and determined by the parties hereto as liquidated damages which the Owner will suffer by reason of such defaults, and not by way of penalty.

In case the Contractor does not substantially complete all of the work covered by this Agreement 38 weeks from the start date of an executed Notice to Proceed, together with any extensions of time which may be granted, the Consultant or Springfield Park District shall determine the number of days the Contractor is in default, and the decision of the Consultant or the Springfield Park District shall be final and binding upon both parties hereto. It is further agreed that if the Owner shall accept any work or make any payments

under this Contract after any such default, such acceptance, payment or payments shall not in any respect constitute a waiver or modification of any of the provisions hereof, and particularly the provisions in regard to LIQUIDATED DAMAGES for delays.

INSURANCE

Procurement of the insurance by the Contractor shall be considered solely for the Contractor's obligation or liabilities under the Contract Documents. The Contractor shall remain fully liable and responsible for all such obligations, whether or not the insurance provided by him/her is approved by the Owner and whether or not such insurance is sufficient in amount, quality, or coverage, to protect him/her against liability, and shall pay and make good all such obligations to the full extent such insurance does not cover them.

If the Contractor fails to obtain and continue to maintain any insurance required by the Contract Documents, the Owner may obtain such as the cost of the Contractor, which cost shall be deducted from any sums due to Contractor under the Contract Documents.

The required minimum coverage, unless higher limits are required by law, are as follows:

1. Employer's Liability – Illinois Statutory Limit \$500,000 min.
2. Public Liability and Property Damage (insuring Owner and Contractor)
 - a. Comprehensive General Liability
 - 1.) \$1,000,000 Bodily Injury per person
 - 2.) \$1,000,000 Bodily Injury per occurrence
 - 3.) \$1,000,000 Property Damage each occurrence
(Completed Operations Board Form)
 - 4.) \$2,000,000 Property Damage Aggregate
 - b. Comprehensive Automobile Liability (Owner, Non-owned and Hired)
 - 1.) \$1,000,000 Bodily Injury per person
 - 2.) \$1,000,000 Bodily Injury per occurrence
 - 3.) \$1,000,000 Property Damage per occurrence
3. All Insurance policies shall cover direct operations, sublet work and contractual liability on the part of the Contractor and shall have "XCU" Coverage (i.e., the removal of exclusions for explosions, collapse and underground property damage).

Contractor shall require subcontractors not protected under his insurance to take out and maintain workmen's compensation insurance and insurance of the same kind in amounts specified above. Contractor shall submit evidence of coverage of insurance required.

SCHEDULES

The Contractor shall, at all times, keep the Project Consultant or Springfield Park District informed of the progress of the work, methods, and proposed schedules and sequences.

WORK

“Work” includes all materials, labor and use of tools, equipment and services and all other items necessary to complete construction in full compliance with the terms of the contract.

BID ACCEPTANCE

The Springfield Park District reserves the right to accept, or reject, any or all proposals, and to waive any technicalities in any or all proposals.

All specifications, drawings, and this Project Manual shall become part of the Contract.

COMPLIANCE WITH STATE LAWS

Each bidder shall thoroughly acquaint him/her with all provisions of the State of Illinois laws pertaining to labor and working conditions on public projects and, by submitting a proposal for this work, acknowledges that he/she is cognizant of such laws and affirms that if awarded a contract, he/she will comply with all the provisions of such statutes which specifically include, but are not limited to, the following:

1. An Act to give preference in construction of public work projects and improvements to citizens of the United States who have resided in Illinois for one (1) year.
2. An Act to prohibit discrimination and intimidation on account of race or color in employment under contracts for public buildings or public works. All contracts for work or for services of any kind shall incorporate the following cause: “In any work or services performed discrimination because of race, color, creed or national origin is prohibited.”
3. Contractor shall be prequalified with Illinois Fair Employment Practices Commission and shall list such prequalification number on the appropriate space shown on the proposal.

PERMITS, BUILDING LAWS AND ORDINANCES

The Contractor shall obtain and pay for all permits and inspector’s fees required without extra cost to the Owner.

PAYMENT

The Contractor shall submit with his/her application for payment a “Contractor’s Affidavit”, duly witnessed, that he/she has duly discharged his/her obligations and that no

liens are against the amount requested. Contractor shall also furnish "Waiver of Lien" from subcontractor and material suppliers, requiring payment for the materials involved in the amount being requested. After payment of the work, the Board shall be obliged to no individual or supplier of material for any contractor's unpaid bills.

METHOD OF PAYMENT

Payment for work performed under this contract is to be made in cash or check from funds provided by the Owner for the purpose of financing this project. Partial payments shall be made no later than the tenth (10th) day of the month next following the application for payment by the Contractor. Final payment shall be made within thirty (30) days after completion and acceptance of the complete project. Partial payment shall be for 90% of the value of work completed with 10% being retained by owner until the project is 100% completed.

SUBCONTRACTORS

The Contractor, upon request, shall submit a list of subcontractors to the Owner. These must be acceptable to the Owner prior to commencing work. The Contractor shall be fully responsible to the Owner for acts and omissions of his/her subcontractors. Nothing contained in the Contract documents shall create any contractual relations between any subcontractor and the Owner or representative thereof.

OWNERS RIGHT TO TERMINATE CONTRACT

If the Contractor should be adjudged bankrupt, or if he/she should make a general assignment for the benefit of this creditors, or if a receiver should be appointed on account of his/her insolvency, or if he/she should persistently or repeatedly refuse or should fail, except in cases for which extension of time is provided, to supply enough skilled workmen, or proper material, or persistently disregard laws, ordinances, or the instruction to the Owner, and/or it's representative or otherwise be guilty of a substantial provision of the contract, then the Owner may without prejudice to any other right or remedy and after giving the contractor seven (7) days written notice, terminate the employment of the Contractor and take possession of the premises and all material, tools and appliances thereon and finish the work by whatever means may be expedient. In such case, the Contractor shall not be entitled to receive any further payment until work is finished. If the expense of finishing the work shall not exceed the unpaid balance, such excess shall be paid to the Contractor. If such expense, however, shall exceed the amount of the unpaid balance, the Contractor shall pay the difference to the Owner.

OMISSIONS

The drawings and specifications are intended to cooperate. Anything shown on the drawings but not mentioned in the specifications or vice-versa, or anything not expressly set forth in either, but which is reasonably implied shall be furnished as though specifically shown and mentioned in both, without any extra charge. Should anything be omitted from the drawings necessary to the proper construction of the work herein described, it shall be the duty of the Contractor to so notify the Consultant or the Springfield Park District before

signing this Contract, and in the event of the Contractor failing to give such notice, he/she shall make good any damage or defects in his/her work caused without extra charge.

CHANGES IN WORK

Minor modifications in drawings and specifications may be made by the Owner to effect an improvement in the completed work where such modification is accepted with the understanding that it makes no change in the contract price or time, and it is with prejudice to any and all rights of the Owner under the Contract and Bond.

Where an adjustment in contract price or time is involved, the requirements of the Contractor shall not be changed or modified except by supplemental written agreement of a "change order". The "change order" shall describe the change, fix the sum thereof, and/or the modifications of the contract time involved.

No charge for any extra work or material will be allowed unless the same has been ordered by the Owner or its representative.

INTERPRETATION

All questions or disagreements between the Owner and the Contractor relating to the interpretation of the drawings and specifications, or kind and quality of material and workmanship required thereby shall be referred to the Consultant or the Springfield Park District. Consultant or Springfield Park District decisions shall be final, conclusive, and without equal.

DETAIL AND WORKING DRAWINGS

Additional detail and working drawings will be furnished in amplification of the contract drawings as they may be required. All such additional drawings as they are furnished are to be considered of equal force with those which accompany these specifications. A complete set of drawings and specifications must be kept at the work site.

MATERIALS

Unless otherwise specified all materials shall be new and of quality equal to the manufacturer's representatives of the product specified. Where no material is specified by name of type, its quality shall conform to the Standards of the ASTM. Each Contractor shall, if required, furnish satisfactory evidence as to the kind and quality of his/her materials. All materials in or designed for the work shall always be properly housed or protected, particular care being taken of all finished parts.

LIMITS OF OPERATION

The Contractor shall confine his/her apparatus, the storage of material and the operation of his/her workmen to the limits directed by the representative of the Owner.

GUARANTEE

If, within one (1) year after the acceptance of the Work or within such longer period of time as may be prescribed by law or by the terms of any applicable special guarantee, any of the Work is found to be defective, the Contractor shall correct promptly after receipt of a written notice from the Owner.

UTILITY LOCATIONS

The location, size and type of material of existing underground utilities indicated on the plans are not represented as being accurate, sufficient or complete. It shall be the Contractor's responsibility to determine the actual location of all such facilities.

CONTRACTOR'S RESPONSIBILITY FOR SAFETY

The Contractor shall do all work necessary for safety and be solely and completely responsible for conditions on the jobsite, including safety of all persons and property during the contract period. This requirement shall apply continuously and not be limited to normal working hours.

SUBSURFACE CONDITIONS

The Contractor shall assume the risk of meeting quicksand, hardpan, boulder clay, rubbish, buried railroad ties and all other unforeseen obstacles. No claim for any amount of money beyond the contract price of the work will be entertained or allowed because of the nature of the ground in which excavation is made. Bidders shall make such borings as they deem necessary to determine the subsurface conditions that may be encountered.

EARTHWORK

The Contractor shall remove and dispose of all unsuitable material off-site as required for construction of the project according to the plans. This work shall be considered to the contract.

SUBGRADE APPROVAL

NA

TRAFFIC CONTROL

YES

AUTHORITY OF THE CONSULTANT

The Consultant or his designate shall represent the Owner in all matters relating to the Construction of the Project. All correspondence, changes, additions, deletions, or corrections regarding these project documents shall be directed to the Consultant.

The Consultant shall have the authority to stop the work when it may be necessary to insure the proper execution of the contract. He/She shall have the authority to order the removal of any work completed which does not comply with the plans of the modifications.

The Consultant shall decide all questions which may arise relative to performance of the contract and his/her decision shall be final and binding.

The Contractor shall preserve all lines and grades and inform the Consultant at least 48 hours in advance of needing additional field staking.

The Contractor shall always have on the job a competent superintendent who shall have authority to act in his behalf of any orders received from the Consultant. The Contractor shall name in writing one general superintendent who has authority to provide direction to and coordinate for all the various trades and crews utilized throughout the construction of this work.

Any Contractor desiring to work any hours other than the regular working hours shall inform the Consultant in advance. No additional compensation will be allowed for overtime work.

If there is no Contracted Consultant for this project, this authority is given to the Springfield Park District staff.

Acceptance or Non-Acceptance of Tenders

Contractors are advised that Springfield Park District reserves the right to accept any tender or reject all. Tenders shall be irrevocable and remain open for acceptance by Springfield Park District for a period of ninety (90) days from the tender closing date. **The Springfield Park District shall accept the lowest responsible bid, if any.**

Springfield Park District may refuse to consider a tender should any of the following conditions exist:

- * A tender is not submitted as required (e.g. tender submitted after the due time and date, required information not provided, etc.)
- * All addenda are not acknowledged in the Submission.
- * Any other defect which, in the opinion of Springfield Park District brings the validity of the tender into question

In order to obtain the most advantageous offer for Springfield Park District, it reserves the right in its sole discretion:

- * To waive irregularities and/or minor non-compliance by any Contractor with the requirements of this Tender,
- * To request clarification and/or further information from one or more Contractor after closing without obligation to offer the same opportunity to all Contractors,
- * To enter into negotiations with one or more Contractors without obligation to negotiate with, or, offer the same opportunity to, all Contractors,
- * If negotiations with a Successful Contractor do not result in a Contract Agreement, to enter into negotiations with any other Contractor regardless of such Contractor's evaluation score, or to discontinue negotiations and terminate this Tender, at its option.

Contractors are advised however to submit a complete offer as their tender. Any waiver, clarification or negotiation will not be considered as an opportunity for Contractors to correct errors in their tender.

It is understood and accepted by the Contractor that all decisions on whether a tender satisfies the Mandatory Requirements and meets, or to what degree it meets, the stated evaluation criteria are the judgment of Springfield Park District in its sole discretion.

Springfield Park District is not obligated to award any contract as a result of the Tender and reserves the right in its sole discretion to cancel this Tender process at any time before or after closing without providing reasons for such cancellation.

Springfield Park District reserves the right to negotiate provisions in addition to those stipulated in this Tender or proposed by the Successful Contractor.

CONTRACT

1. THIS AGREEMENT, made and concluded this ____ day of _____, 20____, between Springfield Park District known as the party of the first part, and _____ (Contractor) his/their executors, administrators, successors or assigns, known as the party of the second part.

2. WITNESSETH: That for and in consideration of the payments and agreements mentioned in the Project Manual hereto attached, to be made and performed by the party of the first part, and according to the terms expressed in the Bond referring to these present, the party of the second part agrees with said party of the first part at his/their own proper cost and expense to do all the WORK, furnish all materials and all labor necessary to complete the WORK in accordance with the Plans and Specifications hereinafter described and in full compliance with all of the plans of this agreement and the requirements of the Consultant and/or Springfield Park District under it.

3. And it is also understood and agreed that the Project Bid Package and Contract Bond hereto attached, and the Plans for Springfield Rink Floors and Plant Replacement, are all essential documents of this Contract and are a part hereof.

4. II WITNESS WHEREOF, the said parties have executed these presents on the date above mentioned.

For the OWNER
Party of the First Part

Signature: _____

By: Derek Harms

Title: Executive Director

For the CONTRACTOR
Party of the Second Part

Signature: _____
(President, Party of the Second Part)

By: _____

Attest:

(Clerk or Notary Public)

Title: _____

(Corporate Seal)

(If a Co-Partnership) _____ (SEAL)
_____ (SEAL)
_____ (SEAL)

NOTICE TO PROCEED

To: _____ Date: _____

Project: _____

You are hereby notified to commence **WORK** in accordance with the Agreement dated

_____, 20____, on or after January 1st, 2025.

By: _____

Title: _____

Acceptance of Notice

Receipt of the above NOTICE TO PROCEED is hereby

Acknowledged by _____

Title: _____

This the _____ day of _____, 20_____.

Please return an **original signed** copy of this document to the:

Springfield Park District

ATTN: _____

2500 South 11th Street

Springfield, IL 62703

CHANGE ORDER

Order No. _____

Date: _____

Agreement Date: _____

NAME OF PROJECT: _____

OWNER: _____

CONTRACTOR: _____

JUSTIFICATION: _____

Change to CONTRACT PRICE: \$ _____

Original CONTRACT PRICE: \$ _____

Current CONTRACT PRICE adjusted by previous CHANGE ORDER \$ _____

The CONTRACT PRICE due to this CHANGE ORDER will be (increased) (decreased) by:

The new CONTRACT PRICE including this CHANGE ORDER will be \$ _____

Change to CONTRACT TIME: _____

The CONTRACT TIME will be (increased) (decreased) by _____ calendar days.

The date for completion of all work will be _____ (Date)

Requested by: _____

Recommended by: _____

Accepted by: _____

ENGINEERING ORDER

DATE:

EO#

IDENTIFIED BY:

ASSIGNED TO:

TOTAL NO. PAGES

CHANGE LEVEL:

Minor

Major

CLIENT/DRAWING No:

CURRENT REVISION #:

ADDENDUM ONLY

REVISE DOCUMENT

WAS

IS NOW

REASON FOR CHANGE:

SPECIAL INSTRUCTIONS:

ENGINEER APPROVAL:

AS IS

PER MARKUP

INITIALS:

DATE:

OWNER ACKNOWLEDGEMENT/APPROVAL:
COMPANY:

NAME:

DATE:

CONTRACTOR ACKNOWLEDGEMENT:
COMPANY:

NAME:

DATE:



Appendix A

Contract Specifications

PART 1 – ICE RINK
GENERAL

1.1 Scope of Work

- .1 The objectives of this project encompass the following:
 - .1 Provide a lifecycle replacement for the refrigeration equipment and plant control system serving the two ice rinks at the Nelson Center located at 1601 North 5th St, Springfield, Illinois 62703.
 - .2 Provide a lifecycle replacement for two ice rink concrete floors.
 - .3 Provide a lifecycle replacement for a dasher board system
 - .4 Remove, store, and reinstall a dasher board system.
 - .5 Provide a design-build electrical system.
 - .6 Execute work using the most effective use of time and resources.
 - .7 Minimize disruption of arena operation, and co-ordinate any required service disruption with the Owner and the Consultant.
 - .8 Work may commence, at the earliest, by 01-Jan-25.
 - .9 All work is to be substantially completed by 24-Sep-25.
 - .10 Work is to be completed as per Appendix C: Project Schedules.
 - .1 The contractor may propose alternative schedules to those outlined in Appendix C: Construction Project Schedule and Appendix D: User Group Project Schedule. Proposed schedules must be coordinated with the Owner and Consultant to ensure that all project milestones are met.
 - .2 Construction schedule milestones include the following:
 - .1 Refrigeration Plant R-22 Pump-Out – 03-Mar-25
 - Rink #2 R-22 Pump-Out – 03-Mar-25
 - Rink #2 Slab Demolished – 17-Mar-25
 - Rink #2 Floor Constructed – 12-May-25
 - Rink #1 R-22 Pump-Out – 02-Jun-25
 - Rink #2 Floor Cured – 09-Jun-25
 - Refrigeration Plant Demolished – 13-Jun-25
 - Rink #1 Slab Demolished – 16-Jun-25
 - Rink #2 Boards and Glass Reinstalled – 23-Jun-25
 - Temporary Refrigeration Plant Installed – 24-Jun-25
 - Rink #2 Ice Built – 07-Jul-25
 - Refrigeration Plant Installed – 08-Aug-25
 - Rink #1 Floor Constructed – 11-Aug-25
 - Functional Commissioning Completed – 19-Aug-25
 - Rink #1 Floor Cured – 08-Sep-25
 - Rink #1 Boards and Glass Installed – 15-Sep-25

Rink #1 and Rink #2 Connected to New Plant – 16-Sep-25

Rink #1 Ice Built – 24-Sep-25

Performance Commissioning Completed – 08-Oct-25

- .11 If the work is not substantially completed by the substantial completion date, the contractor shall be required to provide and connect a temporary refrigeration plant to the system, at no additional cost to the Owner.

1.2 Definitions

- .1 Rink Floors and Plant Replacement: This replacement consists of life cycle upgrades of the refrigeration system and concrete floors for the ice rink, as well as other rink engineering components. It comprises all fully operational and functional elements, including equipment, software, and programming interfaced to the associated work of other related trades. This includes packaged refrigeration systems, pumps, refrigeration field piping, water field piping, automation equipment, automation programming, instrumentation, a dasher board system, concrete work for the cold and warm floor, an adiabatic fluid cooler stand, housekeeping pads, and electrical work.
- .2 Contractor: The single Contractor to provide the work of this Bid Document. This Contractor shall be the supplier, installer, and commissioner. This party shall be the contractor signatory to the contract, and shall take on all responsibilities therein. The Contractor shall supply all materials, labour, and equipment required to complete all work and provide all fully functional deliverables.
- .3 The Owner: For the specifications herein the Springfield Park District shall be referred to as The Owner.
- .4 The Consultant: For the specifications herein I.B. Storey US Inc shall be referred to as the Consultant.

1.3 Rink Floors and Plant Replacement Description

- .1 The removal and disposal of existing, supply, and installation of equipment, testing, start-up and warranty of an ice rink refrigeration system and rink engineering components as outlined.
- .2 The adiabatic fluid cooler stand and housekeeping pads are the responsibility of the contractor.
- .3 The intent of the Rink Floors and Plant Replacement is that minimal loss of ice time will occur. This contractor must be able to demonstrate to the Owner that a proper plan be implemented such that the allotted time for installation is satisfied.
-

- .1 If the start-up date for the refrigeration plant does not occur by the substantial completion date, the Contractor will be responsible for supplying and installing a rental refrigeration system at no cost to the Owner. The Contractor is responsible for all equipment selection and functionality in this scenario.
- .2 At the option of the Contractor, a rental refrigeration system may be provided in lieu of meeting the substantial completion date. This must be noted at the time of bidding and include all costs relating to switching-over the plant from the rental refrigeration system to the permanent system. This must be approved by the Owner. The Contractor is responsible for all equipment selection and functionality within this option.
- .4 Supply and install rink engineering components, including packaged refrigeration systems, condensing equipment, pumps, valves, piping, back up control equipment, ice rink floor materials, dasher boards, and labour.
- .5 The work shall consist of the provision of all labour, materials, tools, equipment, testing, commissioning, training services, transportation, shipping, handling, administration, supervision, management, insurance, temporary protection, cleaning, removal, installation, cutting and patching, warranties, services, and items, even though these may not be specifically mentioned in this documents which are required for the complete, fully functional and commissioned system.
- .6 Provide a complete, neat and workmanlike installation. Use only employees who are certified journeyman or registered apprentices (under the supervision of a journeyman). The labour used to carry out the work shall be skilled, experienced, trained, and familiar with the specific equipment, software, standards and configurations to be provided for this Project. Contractors must submit registration numbers for key personnel that are certified journeyman.
- .7 Manage and coordinate the work in a timely manner in consideration of the Project schedule.

1.4 Drawings Package

- .1 Drawings packages have been issued with this specifications document and are referred to as 24-009 PKG01 Springfield Park District – Detailed Design Package.
 - .2 In the event of discrepancy between the drawings package and this specifications document, the specifications document shall prevail unless otherwise noted. Any discrepancies should be brought to the Owner's attention prior to proceeding.
-

1.5 Quality Assurance

.1 General

- .1 The Contractor shall be regularly engaged in the installation and service of mechanical, refrigeration, and heating systems in Illinois.
- .2 The system components included in this project shall consist of the products from manufacturers regularly engaged in the production of refrigeration and mechanical equipment, and shall be the manufacturer's latest standard of design at the time of bid.

.2 Workplace Safety and Hazardous Materials

- .1 Provide a safety program in compliance with the Contract Documents.
 - .2 Contractor shall have a corporately certified comprehensive Safety Manual and a designated Safety Supervisor for the Project.
 - .3 The Contractor and its employees and subtrades comply with local, state, and federal safety regulations.
 - .4 The Contractor shall ensure that all subcontractors and employees have written safety programs in place that covers their scope of work, and that their employees receive the training required by the Occupational Safety and Health Administration for the State of Illinois for at least each topic listed.
 - .5 Hazards created by the Contractor or its subcontractors shall be eliminated before any further work proceeds.
 - .6 Hazards observed but not created by the Contractor or its subcontractors shall be reported to the Consultant and the Owner within the same day. The Contractor shall be required to avoid the hazard area until the hazard has been eliminated.
 - .7 The Contractor shall sign and date a safety certification form prior to any work being performed, stating that the Contractors' company is in full compliance with the Project safety requirements.
 - .8 The Contractor's safety program shall include written policy and arrangements for the handling, storage and management of all hazardous materials to be used in the work in compliance with the requirements of the Authorities Having Jurisdiction at the Project site.
 - .9 The Contractor's employees and subcontractor's staff shall have received training as applicable in the use of hazardous materials and shall govern their actions accordingly.
-

- .3 Quality Management Program
 - .1 Designate a competent and experienced employee to provide Project Management. The designated Project Manager shall be empowered to make technical, scheduling and related decisions on behalf of the Contractor. At minimum, the Project Manager shall:
 - .1 Manage the scheduling of the work to ensure that adequate materials, labour and other resources are available as needed
 - .2 Manage the financial aspects of the Contract, with respect to the budget and payment applications.
 - .1 Be responsible for the work and actions of the workforce on site

1.6 References

- .1 The Contractor shall fully comply with all codes and standards applicable to this type of work, including;
 - .1 State Occupational Safety and Health Administration (OSHA)
 - .2 The National Electrical Code
 - .3 National Fire Code
 - .4 ASME Boiler and Pressure Vessel Code (BPVC)
 - .5 Underwriters Laboratories (UL) listing and labels
 - .6 American National Standards Institute (ANSI)
 - .7 American Society for Testing and Materials (ASTM)
 - .8 American Society of Heating, Refrigeration and Air-Conditioning Engineers (ASHRAE) Standards:
 - .1 ASHRAE Standard 15 - Safety Standard for Refrigeration System
 - .2 ASHRAE Standard 34 – Designation and Safety Classification of Refrigerants.
- .2 In the case of conflicts or discrepancies, the more stringent regulation shall apply
- .3 All work shall meet the approval of the Authorities Having Jurisdiction at the project site

1.7 Shop Drawings

- .1 Manufacturer’s data sheets must be used for each product included as part of the scope of work. The submittal package must include:
 - .1 Install preparation instructions, methods, and recommendations.
 - .2 Safety requirements and details.
 - .3 Operating and design parameters such as temperatures, pressures, RPM, and physical size.
-

- .4 Performance and equipment specifications.
- .5 Storage and handling requirements and recommendations.
- .2 All specifications for equivalents being offered must be received electronically by the Consultant for review no later than the question deadline during the bidding process.
 - .1 For maintenance purposes, equivalents for equipment will only be approved if all equipment of a similar type meet the specifications (such as pumps).
- .3 Shop drawings must also contain complete wiring and schematic diagrams, sequences of operation, control system bus layouts, and any other details required to demonstrate that the system has been coordinated and will properly function as a system.

1.8 Record
Documentation

- .1 Provide two (2) paper copies and one (1) USB digital copy of operating and maintenance manuals for all installed equipment pertaining to this contract, including as-built drawings
 - .2 After completion of all tests and adjustments, the contractor shall provide a copy of all as-built information and product data.
 - .3 On Site documents: Maintain at job site, one copy each of the following (but is not limited to):
 - .1 Contract drawings.
 - .2 Specifications.
 - .3 Addenda.
 - .4 Reviewed shop drawings.
 - .5 List of outstanding shop drawings.
 - .6 Change orders.
 - .7 Other modifications to Contract.
 - .8 Copy of approved Work schedule.
 - .9 Health and Safety Plan and other Safety related documents.
 - .10 Manufacturers' installation and application instructions.
 - .11 Labour conditions and wage schedules.
 - .12 Other documents as specified.
 - .4 Manual shall be bound in three (3) ring binders and contain, as a minimum, the following:
 - .1 System operation and maintenance instructions, troubleshooting guidelines and operating log.
 - .2 Safety bulletins and material safety data sheets.
 - .3 Reviewed and approved (stamped) shop drawings
-

- .4 Completed and approved Application for water connection form (As Required). Contractor to comply with all local and state backflow prevention requirements, where applicable
- .5 Approvals by all Authorities having jurisdiction.
- .6 Equipment operation and maintenance instructions
- .5 As-built drawings must contain, as a minimum, the following;
 - .1 Refrigeration equipment layout and schedule
 - .2 Mechanical System equipment layout and schedule
 - .3 Control Sequences of Operation
 - .4 Structural Drawings and Plans
 - .5 Electrical Wiring Diagrams, Layouts and Schematics
 - .6 All flow schematics
- .6 Prepare an index of all submittals and shop drawings for the installation. Index shall include a shop drawing identification number, Contract Documents reference and item description.
 - .1 Adiabatic fluid cooler stand and housekeeping pad design, as required in this scope of work, will be provided by the contractor. I.B. Storey US Inc. will not review, comment, or approve any documentation related to this aspect of the project.
- .7 The contractor shall correct any errors or omissions noted in the first review.
- .8 Within two (2) weeks of contract award the contractor shall provide a schedule, in a Gantt Chart to the Owner and the Consultant, which summarizes all construction timelines and milestone dates. Including, but not limited to:
 - .1 Shop drawing submittal and review time;
 - .2 Equipment order dates;
 - .3 Lead time;
 - .4 Site construction milestones (demolition, package placement, etc.)
 - .5 On-site completion;
 - .6 System start-up;
 - .7 Substantial completion;
 - .8 Training and owner turnover.

1.9 Commissioning

- .1 Upon completion of the work, the contractor shall start up and calibrate the system to ensure all installed components start, and are installed properly.
 - .2 The contractor shall provide the Consultant with a Start Up checklist four (4) weeks prior to project completion for review and approval.
-

The checklist shall include, but is not limited to, the following elements:

- .1 Equipment status
- .2 Time of day
- .3 Inlet temperatures
- .4 Outlet temperatures
- .5 Suction pressures
- .6 Discharge pressures
- .7 Liquid flow rates
- .8 Valve positions
- .9 Power reading including: power draw, voltage, current, power factor

- .3 An initial equipment check shall occur three (3) days prior to start up to ensure functionality of all components. Prior to this check, all equipment shall be visually inspected.
- .4 The Contractor shall provide the Consultant with an automation point-to-point report prior to start up to ensure functionality of all automation points.
- .5 Once start-up has occurred, the Start-Up Checklist shall be completed. The checklist shall be completed when the system is under load and at steady state to ensure all equipment is running. The contractor shall be immediately available in the hours following start up to provide start up services and to rectify issues immediately as they arise.
- .6 After substantial completion independent performance commissioning shall be completed by I.B. Storey and a deficiency list shall be provided to the contractor. Following receipt of the deficiency list the contractor shall provide weekly updates in writing of the completion status of the deficiencies, including proof of completion. After completion of all deficiencies the Consultant shall perform one final inspection, any requisite subsequent inspections shall be at the cost of the contractor (\$1,200 per inspector per occurrence.)

1.10 Training

- .1 The contractor shall provide the owner's staff with two (2) up to four (4) hour training sessions in coordination with the Owner's staff and the packaged refrigeration system manufacturer.
 - .1 First Session – to occur at plant start-up, with training specifically geared toward plant start-up
 - .2 Second Session – to occur at a later time for other arena staff in the event they are unable to attend, and to address any operational issues that arise during regular operation

- .2 The date and time of the training sessions shall be at the option of the Owner, and shall be coordinated by the contractor.

1.11 Warranty

- .1 Standard Material and Labour Warranty:
 - .1 Provide a one-year labour and material warranty on the refrigeration system and rink engineering components following substantial completion.
 - .2 If within twelve (12) months from the date of acceptance of a product, upon written notice from the Owner, it is found to be defective in operation, workmanship, or materials, it shall be replaced, repaired, or adjusted at the option of the Contractor at the cost of the Contractor.

PART 2 – REFRIGERATION
PLANT

2.1 Demolition Scope of Work

- .1 The contractor is to remove and dispose the existing refrigeration plant equipment, refrigerant, and systems. The Owner will retain any noted refrigerant, equipment, piping and salvage, once removed, for use.
 - .1 This includes all existing ice rink refrigeration and rink heating equipment being replaced in the refrigeration system upgrade including all heat exchangers, pipes, valves, and fittings.
 - .2 All existing housekeeping pads for all removed equipment are to be removed and disposed except where noted.
 - .3 The existing snow melt pit pump is to be removed and disposed.
 - .4 All refrigerant in the system is to be removed by the Contractor. Existing facility equipment is not to be used to pump-out the refrigerant.
 - .1 This includes the refrigerant in the plant, refrigerant in the cold floor, and glycol in the snow melt pit system.
 - .2 All refrigerant from the plant and cold floor is to be stored on site for the owner to retain.
 - .3 Provide disposal certificates for the glycol.
- .2 The contractor is to remove and dispose the existing piping between the refrigeration plant room and the snow melt pit coil located in the ice resurfacer room.

2.2 Refrigeration Plant Scope of Work

- .1 Supply and install site four (4) magnetic bearing oil-less compressor packaged rink system (ITP-1, ITP-2, ITP-3, ITP-4). The following performance requirements are for each package.
 - .1 Refrigerant: R513a
 - .2 Evaporator Side:
 - .1 Total Capacity: 50 TR (per packaged system, 200 TR total)
 - .2 Fluid: 40% Ethylene Glycol
 - .3 Flow rate: 467 USGPM
 - .4 EFT: 13°F
 - .5 LFT: 10°F
 - .6 Pressure Drop: 33 ft.
 - .3 Condenser Side:
 - .1 Fluid: 40% Ethylene Glycol
 - .2 Flow rate: 220 USGPM
 - .3 EFT: 85°F

- .4 LFT: 93°F
 - .5 Pressure Drop: 25 ft.
 - .4 Power: 52.8 kW
 - .5 Electrical Requirements: 460/3/60
 - .6 Must include Danfoss frictionless, magnetic bearing, oil-less compressors.
 - .7 Compressor must be of high lift design.
 - .8 Manufacturer must have fifteen (15) years experience in integrating Danfoss Turbocor compressor internal protection software for stall and surge situations at various operating conditions.
 - .9 Include a five (5) year warranty on the magnetic bearing compressors only (priced separately on the Bid Forms).
 - .10 Use only hybrid condenser/evaporator vessels set with hybrid film design.
 - .11 Pressure relief valves are to be included on both evaporator and condenser as provided by the manufacturer.
 - .12 Package must include a PLC controller with colour touchscreen.
 - .13 IIOT (Industrial Internet of Things) 4.0 control system capable of controlling multiple independent units.
 - .14 C-UL 508a standard control panel.
 - .15 Controller must be BACnet compatible.
 - .16 Condenser water regulating valve must be included on the package.
 - .17 Wholly independent, standalone packaged units
 - .18 Package manufacturer must be:
 - .1 Nationally recognized supplier of OEM parts
 - .2 Experienced in building units with Danfoss magnetic bearing compressors
 - .19 Package must be able to unload with constant entering water temperature.
 - .20 Packaged System Dimensions:
 - .1 Length: 144.1" (inches)
 - .2 Width: 33.3" (inches)
 - .3 Height: 74.15" (inches)
 - .21 Any deviation from the Standard of Acceptance must maintain the walking path in the room and allow for serviceability of the unit. This must be demonstrated in a Clearances and Interfaces Drawing.
 - .22 Supplier must provide, and comply with the manufacturer's instructions for, rigging, loading, transporting, and un-loading.
-

- .23 Testing data demonstrating performance must be available upon request.
- .24 Contractor is to ensure direct ethernet connection is provided to the packages with a Port 80 access as required by the Manufacturer for remote diagnosis.
- .25 The unit must be protected from physical damage at all times.
- .26 Standard of Acceptance: Thermal Care TCFW375 Limited, or approved equivalent
- .2 Supply and install one (1) Adiabatic Fluid Cooler complete with pre-cooling pads (AFC-1)
 - .1 Capacity: 3,076 MBH
 - .2 WBT: 75.9°F
 - .3 Fluid: 40% Ethylene Glycol
 - .4 Flow Rate: 680 USGPM
 - .5 EGT: 105°F
 - .6 LGT: 95°F
 - .7 Maximum Coil Pressure Drop: 6.37 psi
 - .8 Maximum Sound Pressure: 78 dB(A) at 3' (feet).
 - .9 Ten (10) Fan Motors: 43.8 BHP (total), premium efficiency.
 - .1 Contractor to provide new contactors, fuse blocks, starters, and wiring for the installed fan motor.
 - .2 Motor must be electrically commutated.
 - .10 Electrical Power: 480/3/60
 - .11 Contractor must adhere to all manufacturer's recommended maintenance and operation clearances
 - .12 Contractor to include a drain and manual isolation valve to drain the water connection in the winter.
 - .13 Contractor to include an adiabatic fluid cooler stand which adheres to the manufacturer's recommendations.
 - .14 Water supply line is to be sloped downward.
 - .15 Must include maintenance access ladder, platform, and perimeter handrail options.
 - .16 Must include an on-board controller.
 - .1 Controller must be BACnet open standard communication protocol compatible. Controller must be capable of variable speed control of the fan motors.
 - .2 Controller as a minimum must be able to maintain the leaving glycol setpoint.
 - .17 The control panel must be installed remotely in the refrigeration plant room as indicated on the drawings package.

- .18 Standard of Acceptance: Guntner GFD 090.2A2x5/6AA-E355L/02P.M, or approved equivalent.
 - .3 Supply and install one Prepackaged Pump Skid (CP-1, CP-2, CP-3):
 - .1 Pump package shall have a welded structural steel frame and a solid plate steel pump deck
 - .2 Package shall include the following:
 - .1 Three (3) Armstrong 4030 6x5x11.5 pumps
 - .1 Motor: 30 HP, premium efficiency
 - .2 Power: 460/3/60
 - .3 Flow Rate: 934 GPM
 - .4 Working Fluid: 40% Ethylene Glycol
 - .5 Pumping Head: 86 ft. H₂O
 - .2 Three (3) 8" grooved trim for process pumps
 - .3 Three (3) Armstrong SG-86 suction guides
 - .4 Three (3) Armstrong FTV-8FS Flo-Trex valves
 - .5 10" grooved 3-pump process pump suction manifold
 - .6 10" grooved 3-pump process pump discharge manifold
 - .7 10" grooved second discharge manifold
 - .8 Three (3) 30 HP ACH580-01-046A-4 VFDs mounted on pump deck and wired to pumps
 - .9 Three (3) line reactors wired to input of VFDs (line side)
 - .10 Eight (8) isolation valves
 - .11 Hard pipe conduit for wiring to pumps
 - .3 Standard of Acceptance: Thermal Care, or approved equivalent.
 - .4 Supply and install one Prepackaged Pump Skid (HGP-1, HGP-2, HGP-3):
 - .1 Pump package shall have a welded structural steel frame and a solid plate steel pump deck
 - .2 Package shall include the following:
 - .1 Two (2) Armstrong 4030 5x4x10 pumps
 - .1 Motor: 25 HP, premium efficiency
 - .2 Power: 460/3/60
 - .3 Flow Rate: 660 GPM
 - .4 Working Fluid: 40% Ethylene Glycol
 - .5 Pumping Head: 91.2 ft. H₂O
 - .2 Two (2) 6" grooved trim for process pumps
 - .3 Two (2) Armstrong SG-65 suction guides
 - .4 Two (2) Armstrong FTV-6FS Flo-Trex valves
 - .5 6" grooved 2-pump process pump suction manifold
 - .6 6" grooved 2-pump process pump discharge manifold
-

- .7 Two (2) 25 HP ACH580-01-034A-4 VFDs mounted on pump deck and wired to pumps
 - .8 Two (2) line reactors wired to input of VFDs (line side)
 - .9 Four (4) isolation valves
 - .10 Hard pipe conduit for wiring to pumps
 - .3 Standard of Acceptance: Thermal Care, or approved equivalent.
 - .5 Supply and install one Prepackaged Pump Skid (WFP-1, WFP-2, WFP-3):
 - .1 Pump package shall have a welded structural steel frame and a solid plate steel pump deck
 - .2 Package shall include the following:
 - .1 Three (3) Armstrong 4030 1.5x1x6 pumps
 - .1 Motor: 1 HP, premium efficiency
 - .2 Power: 460/3/60
 - .3 Flow Rate: 31 GPM
 - .4 Working Fluid: 40% Ethylene Glycol
 - .5 Pumping Head: 36.1 ft. H₂O
 - .2 Three (3) 2" grooved trim for process pumps
 - .3 Three (3) Armstrong SG-1515TF suction guides
 - .4 Three (3) Armstrong FTV-2GS Flo-Trex valves
 - .5 3" grooved 3-pump process pump suction manifold
 - .6 2" grooved 3-pump process pump discharge manifold
 - .7 2" grooved second discharge manifold
 - .8 Eight (8) isolation valves
 - .3 Standard of Acceptance: Thermal Care, or approved equivalent.
 - .6 Supply and install one (1) Automatic Cold Loop Feeder (GF-1)
 - .1 Size: 100 Gallons
 - .2 Tank Material: Plastic
 - .3 Include pump with automatic pressure controls
 - .4 Must include a diverting valve.
 - .5 Must include a fluid level switch to automatically shut the pump off at a low tank level.
 - .6 Standard of Acceptance: Axiom SF-100L, or approved equivalent.
 - .7 Supply and install one (1) Automatic Warm Loop Feeder (GF-2)
 - .1 Size: 100 Gallons
 - .2 Tank Material: Plastic
 - .3 Include pump with automatic pressure controls
 - .4 Must include a diverting valve.
-

- .5 Must include a fluid level switch to automatically shut the pump off at a low tank level.
 - .6 Standard of Acceptance: Axiom SF-100L, or approved equivalent.
 - .8 Supply and install one (1) Cold Loop Air Separator (AS-1)
 - .1 Shell Material: Fabricated Steel
 - .2 Maximum Working Pressure: 165 PSI
 - .3 Connections to be 150# flanged ANSI raised face.
 - .4 Design and built with the latest ASME pressure vessel code, section VIII, Division 1.
 - .5 Must include a blowdown connection for cleaning.
 - .6 Standard of Acceptance: Armstrong VA-10-U, or approved equivalent.
 - .9 Supply and install one (1) Cold Loop High-Capacity Air Vent
 - .1 Install on the cold floor loop above the air separator.
 - .2 Air Elimination Range:
 - .1 150 psi at 250°F
 - .2 175 psi at 150°F
 - .3 Standard of Acceptance: Armstrong AAE-750, or approved equivalent.
 - .10 Supply and install one (1) Warm Loop Air Separator (AS-2)
 - .1 Shell Material: Fabricated Steel
 - .2 Maximum Working Pressure: 165 PSI
 - .3 Connections to be 150# flanged ANSI raised face.
 - .4 Design and built with the latest ASME pressure vessel code, section VIII, Division 1.
 - .5 Must include a blowdown connection for cleaning.
 - .6 Standard of Acceptance: Armstrong VA-8-U, or approved equivalent.
 - .11 Supply and install one (1) Warm Loop High-Capacity Air Vent
 - .1 Install on the warm floor loop above the air separator.
 - .2 Air Elimination Range:
 - .1 150 psi at 250°F
 - .2 175 psi at 150°F
 - .3 Standard of Acceptance: Armstrong AAE-750, or approved equivalent.
 - .12 Supply and install one (1) Cold Loop Expansion Tank (EX-1)
 - .1 Acceptance Volume: 128 gal.
 - .2 Total Volume: 158 USGAL
 - .3 Type: Pre-charged heavy-duty butyl diaphragm.
 - .4 Include tank saddles to install horizontally.
-

- .5 Shell Material: Carbon Steel
 - .6 Head Material: Carbon Steel
 - .7 Working Temperature: 240°F
 - .8 Working Pressure: 125 PSI
 - .9 ASME Certified Construction
 - .10 Standard of Acceptance: Armstrong AX-260V, or approved equivalent

 - .13 Supply and install one (1) Warm Loop Expansion Tank (EX-2)
 - .1 Acceptance Volume: 48.5 gal.
 - .2 Total Volume: 60 USGAL
 - .3 Type: Pre-charged heavy-duty butyl diaphragm.
 - .4 Include tank saddles to install horizontally.
 - .5 Shell Material: Carbon Steel
 - .6 Head Material: Carbon Steel
 - .7 Working Temperature: 250°F
 - .8 Working Pressure: 125 PSI
 - .9 ASME Certified Construction
 - .10 Standard of Acceptance: Armstrong AX-100V, or approved equivalent

 - .14 Supply and install one (1) Glycol Relief High Capacity Air Vent
 - .1 Install on the warm loop.
 - .2 Provide manual isolation valves before the high capacity air vents.
 - .3 Pressure Range: 30-150 PSI
 - .4 Pressure Setting: 100 PSI
 - .5 Maximum Temperature: 250°F
 - .6 Standard of Acceptance: Watts 174A, or approved equivalent.

 - .15 Supply and install one (1) Hydraulic Separator (HS-1)
 - .1 Size: 2.5"
 - .2 Capacity: 80 GPM
 - .3 Fluid: 40% Ethylene Glycol
 - .4 Standard of Acceptance: Caleffi 548062A, or approved equivalent.

 - .16 Where noted in the specifications or the drawings, pressure gauges must meet the following requirements:
 - .1 Pressure Range: 0 – 100 PSI
 - .2 Standard of Acceptance: Kodiak Controls Inc. KC201 D25 100

 - .17 Where noted in the specifications or the drawings, analog thermometers must meet the following requirements:
 - .1 Type: Adjustable angle liquid-in-glass thermometer.
 - .2 Range: 0°F to 160°F
-

- .3 Contractor to include all thermowells as required.
- .4 Standard of Acceptance: Trerice, or approved equivalent.

.18 Housekeeping pads

- .1 The contractor is to form and pour new concrete housekeeping pads with steel reinforcing as required, for all new base/floor mounted equipment, including vessels, pumps, tanks, etc.
- .2 Concrete pads are to be a minimum of 4" tall, unless otherwise noted.
- .3 Steel bases of the equipment are to be grouted and/or filled with concrete as required to limit noise and vibration. The foundation should be sufficiently substantial to absorb any excessive vibration and permanently support the base at all times.
- .4 Concrete pads are to be finished level.
- .5 The foundation must be poured well in advance of the installation to allow proper time for drying and curing.
- .6 The elevations of all concrete pads are to be painted high visibility safety yellow, using one coat of primer and two coats of paint.

.19 Where noted in the specifications or the drawings, variable frequency drives (VFD's) must meet the following requirements:

- .1 The VFD shall provide microprocessor-based control for three-phase induction motors. The controller's full load output current rating shall be based on 77°F ambient. Installed with internal reactors
 - .2 The VFD shall have selectable switching frequency between 8kHz and 12kHz to reduce motor noise and avoid increased motor losses as standard.
 - .3 The VFD shall maintain the power factor at no less than 0.98 at nominal load.
 - .4 The VFD shall have a one (1) minute overload current rating of 110% and a two (2) second starting current of at least 130%.
 - .5 The VFD shall be capable of operating any NEMA design B squirrel cage induction motor, regardless of manufacturer, with a horsepower and current rating within the capacity of the VFD.
 - .6 Humidity: 5% to 95% (non-condensing and non-corrosive).
 - .7 Ambient Temperature: 5°F to 104°F (VT) with de-ratings up to 122°F.
 - .8 Diagnostic Features must include fault history. The VFD will record and log faults and indicate the most recent first. The system will log up to three faults.
-

- .9 Must include a forced bypass contact and AC line-side reactors.
 - .10 Functionally, automatic disconnection of the supply must occur in the event of a loss of continuity of the projective conductor.
 - .11 Auto-bypass functionality must be provided. Bypass contactors to be IEC rated.
 - .12 Standard of Acceptance: ABB ACH580 series, or approved equivalent.

 - .20 Supply and install one (1) plant room exhaust fan (EF-A)
 - .1 Drive Type: Belt
 - .2 CFM: 395
 - .3 Total External SP: 0.1
 - .4 Motor: 1/4 HP
 - .5 Power: 115/60/1
 - .6 Sones (inlet): 22
 - .7 Include a disconnect switch, factory mounted.
 - .8 Include a backdraft damper, gravity operated.
 - .9 Standard of Acceptance: Greenheck BAER-24-02-0305, or approved equivalent
 - .21 Existing exhaust Fan (EF-3) details provided for reference:
 - .1 EF-3 is existing on site.
 - .2 Drive Type: Belt
 - .3 CFM: 5000
 - .4 Total External SP: 0.1
 - .5 Fan RPM:613
 - .6 0.37 BHP
 - .7 Motor: 1/2 HP
 - .8 Power: 115/60/1
 - .9 Sones (inlet): 11.4
 - .10 Model: Greenheck SBE-1L24
 - .22 Supply, install, and connect a temporary refrigeration plant to the Rink #2 system
 - .1 The Contractor is responsible for all equipment selection and functionality for this item.
 - .2 The temporary refrigeration plant must be connected following the reinstallation of the Rink #2 boards and glass and stay connected until functional commissioning of the new refrigeration plant has begun.
 - .1 The expected connection date is 24-Jun-25.
 - .2 The expected disconnection date is 11-Aug-25, to be coordinated with refrigeration plant functional commissioning.
-

2.3 Additional Refrigeration Plant Items

- .1 Provide rental refrigeration system connections as detailed on the design drawings.
 - .2 Supply and install a new charge of glycol for the two (2) rink cold floor systems.
 - .1 Contractor to carry all procurement, transportation, testing, and labour required to provide the glycol charge.
 - .2 Fluid: 40% Ethylene Glycol, including all required additives and inhibitors
 - .3 After charging of the system, the Contractor is required to adjust the concentration to the desired amount. Testing must be completed demonstrating that the required concentration has been achieved. Provide all testing reports to the Consultant.
 - .4 Standard of Acceptance: DOW Chemical's Ambitrol FL40, or equivalent.
 - .3 Any electrical or fire alarm shutdowns required by the Contractor for the scope of work must be approved by the Owner two (2) weeks prior to being performed for coordination purposes.
 - .4 The contractor it to provide one (1) cold floor testing report for the glycol charge after the system has been installed and prior to start-up. This is to verify the fluid properties and concentration.
 - .5 Contractor to provide all required new electrical equipment and modifications to the existing MCC and distribution panels to install the new refrigeration equipment. Reconfiguration is required to provide adequate power to the new equipment.
 - .1 Refer to Part 8 – Electrical Design-Build.
 - .2 All MCC's, VFD's, and starters are to be clearly labelled detailing:
 - .1 Equipment name
 - .2 Source of electrical
 - .3 Voltage and amps
 - .6 All valves and controls should be located at ergonomic heights unless technically unfeasible.
 - .7 Contractor to supply and install a refrigeration room as-built refrigeration system schematic and valve chart detailing all new and existing equipment relevant to the upgrades.
 - .8 Contractor to supply and install a permanent sign with all relevant refrigeration plant information, but not limited to, plant size,
-

prime-mover horsepower, contractor contact information, local emergency service information, and plant refrigerant charge.

- .9 The contractor shall install thermometers on the inlets and outlets of all refrigeration packages, and pressure gauges on all pumps. Pressure gauges are to be dial type and thermometers are analog type as specified.
 - .10 Contractor to provide structural steel support members as required for hanging equipment and pipes.
 - .11 Cutting, patching, sleeving, sealing, and fireproofing of floor, wall and ceiling necessary for all delivery and installation of refrigeration system shall be provided by the contractor.
 - .12 The contractor shall install dust enclosures while performing work in occupied facility zones, which generates large amounts of particulates.
 - .13 The contractor shall carry the cost of all piping, valves, fittings, and adaptors required to make a fully functional system as outlined in the specification herein, even if not specifically mentioned.
 - .14 Site cleanup and removal of construction/demolition debris is the responsibility of the contractor.
 - .15 Equipment layout shall allow adequate clearances for cleaning and maintenance purposes. The proposed clearances must be documented on a Clearance and Interface drawing and submitted to the Owner and the Consultant for comment, prior to commencing work.
 - .16 All installed equipment shall be labelled with placards, and shall be labelled by equipment type in sequential order (Pumps, Expansion Tanks, etc.).
 - .17 Contractor shall seal all building penetrations created/modified under the scope of this contract with a watertight sealant; the penetration shall be painted to match the surrounding building finishes.
 - .18 The contractor shall furnish, supply and install all required refrigerant isolation and control valves in accordance with all applicable codes and standards.
 - .19 The contractor shall provide all required fluids required for a fully functional and operational system including:
 - .1 Glycol Charge
-

- .20 All equipment installations must be constructed in conformance with all local, state, and national code. Any additional requirements from the latest codes and standards supersede any requirements as written in this document.
 - .21 All equipment shall be installed such that it meets or exceeds the manufacturer's recommended installation practices and requirements.
 - .22 Prior to commencing work the contractor shall determine the location of any utility entrances (power, water, sewer), which may interfere with carrying out this work. This shall be done in conjunction with the utility companies, and shall be at the cost of the contractor.
 - .23 The contractor shall provide a new log book ("Ice Rink Log Book") for the facility at turnover, for logging pressures and temperatures.
 - .1 Work with the Consultant for content.
 - .24 Contractor must pay for all local inspections, approvals, and permits as required for the refrigeration plant replacement project.
 - .25 Supply and install a glycol drain/charge valve on each pump in the system.
 - .26 Contractor to coordinate the installation of all equipment with the Automation Contractor. Any required testing and commissioning of the automation system (on top of the back-up or secondary control system) must also be coordinated by the Contractor in this scope.
-

PART 3 - AUTOMATION

3.1 Automation System Functional Intents

.1 Automation system functional intents:

1. R513A Packages

- a. The R513A packages are intended to operate to provide refrigeration to the cold slabs. The four packages are to be staged to operate based on cooling demands from the loads with the lead package rotating between the four units.
- b. When an ice sheet is in operation the supply temperature commanded to the R513A packages are to be set to the rink temperature.
- c. The R513A packages are to have multiple modes of operation depending on ice conditions.
- d. A minimum condenser flow rate of 100 GPM per unit in operation is to be maintained by the condenser pumps.
- e. A minimum evaporator flow rate of 268 GPM per unit in operation is to be maintained by the cold floor pumps.
- f. Startup bypass valve (105) is intended to open for 5 minutes when the R513A packages are starting up.

2. Adiabatic Fluid Cooler

- a. The fluid cooler is to provide cooling to the heat rejection loop when the refrigeration plant is running and the building heat loads are satisfied. The unit will have multiple modes of operation based on the building heating loads required to adequately cool the heat rejection loop. The fluid cooler is to fluctuate its setpoint based on outdoor weather when a fixed heating setpoint is not required.
 - b. A field commissioned minimum glycol leaving temperature must be maintained. If the temperature falls below the commissioned value the unit is to cycle off.
 - c. When the outdoor dewpoint is above 60°F the water feed valve (302) is to open to allow the water pads on the unit to be soaked, leveraging additional capacity through water evaporation and drain valve (301) is to close.
-

- d. When the outdoor dewpoint is below 42°F the water feed valve (302) is to close and the drain valve (301) is to open to allow the system to be automatically drained to prevent freezing on the unit.
3. Cold Floor Pumps
 - a. The cold floor pumps are intended to operate to distribute the cold glycol to the ice sheets from the R513A packages.
 - b. The pumps are to stage in operation with the R513A packages and operate at the same speed to maintain the minimum flow required for the R513A packages. The pumps are to minimize energy use by maintaining a fixed temperature differential.
 4. Condenser Pumps
 - a. The heat rejection pumps are intended to operate to distribute the heating provided by the R513A packages to the snow melt pit, the warm floor, and the adiabatic fluid cooler.
 - b. The pumps are to stage in operation with the R513A packages and operate at the same speed to maintain the minimum flow required for the R513A packages. The pumps are to minimize energy use by matching the required warm glycol flow rates based on what loads are calling for heating.
 5. Warm Floor Pumps
 - a. The warm floor pumps are intended to provide heating to the warm rink floors to prevent frost below the ice rink floors. They are to keep the floor above 40°F and cycle off when the warm floor temperatures are at setpoint.
 6. Snow Melt Valve (203)
 - a. The snow melt valve (203) is intended to operate to maintain the snow melt pit temperature above freezing to ensure proper snow melt when the ice resurfacer dumps snow into the pit.
 7. Exhaust Fans
 - a. The exhaust fan for the plant room (EF-A) is intended to operate based on the required ventilation for the space.
 - b. The exhaust fan for the plant room (EF-3) is intended to operate based on the required ventilation for Carbon Monoxide (CO) and temperature for the space. In addition, the fan will be operated by the refrigerant
-

detector controller to ensure refrigerant levels are below the allowable PPM in the event of a leak.

3.2 Automation Scope of Work

- .1 Plant Control System
 - .1 The Contractor is to supply and install all equipment including controllers for a secondary or back-up control system for the ice rink refrigeration plant.
- .2 Back-up Control System
 - .1 The mechanical contractor is to supply and install all equipment including controllers for a secondary or back-up control system for the ice rink refrigeration plant.
 - .2 The back-up controller is to operate the equipment in the event of a primary control system failure to ensure a fully functional system. This back-up control system will only activate when the manual selector switch is activated.
 - .3 Provide a labelled selector switch that will activate the back-up control system in the event the primary rink Building Management System (BMS) is offline. This switch can then be used to revert back to the BMS one it is functional. Equipment must not turn-off when the switch-over occurs.
 - .4 The control system must be installed and functioning prior to start-up.
 - .5 Standard of Acceptance: Honeywell T775, or approved equivalent.
- .3 Supply and install Power Meters
 - .1 Real Power and Energy Accuracy: $\pm 0.2\%$ from 1% to 100% of rated load.
 - .2 Must be BACnet compatible.
 - .3 Must be able to measure voltages from 120 to 600 Vac and currents from 5 to 6,000 amps in delta (phase to phase) and wye (phase to neutral) configurations.
 - .4 Standard of Acceptance: Honeywell E-mon Class 5000, or approved equivalent.
- .4 Supply and install fluid flow meters
 - .1 Temperature Range: up to 150°F
 - .2 Accuracy: $\pm 0.5\%$ at calibrated velocity
 - .3 Meter shall be insertion type.
 - .4 Meter shall have a single turbine.
 - .5 Standard of Acceptance: Onicon F-1100-10-C3-1221, or approved equivalent.

- .5 Supply and install Weather Stations
 - .1 Temperature: -40°F to 240°F, 0.4°F at 77°F accuracy
 - .2 Must include a selectable output signal of 4-20 mA or 0-10 Vdc.
 - .3 Humidity: 0 to 95% R.H., 3% accuracy
 - .4 Standard of Acceptance: Honeywell H7635C2015, or approved equivalent.
 - .6 Supply and install slab temperature sensors
 - .1 Installed on top of the slab.
 - .2 Sensor Type: PT1000 1097 Ohms at 77°F PTC
 - .3 Temperature sensor is to have a working range of -40°F to 40°F.
 - .4 Standard of acceptance: Honeywell T775-SENS-WT, or approved equivalent.
 - .7 Supply and install Wall CO2 Sensors
 - .1 Capable of 4-20 mA or 0-10 VDC signals.
 - .2 Range of 0 – 2,000 PPM
 - .3 Operating Conditions: -4°F to 122°F, 15 to 90% RH
 - .4 Accuracy: ± 50 ppm + 3% of reading.
 - .5 Response Time: 90 seconds
 - .6 Transmitter Accuracy: ± 0.25% of span.
 - .7 Standard of Acceptance: Greystone CDD4A101, or approved equivalent.
 - .8 Supply and Install Wall CO Sensors
 - .1 Capable of 4-20 mA or 0-10 VDC signals.
 - .2 Range of 0 – 300 PPM
 - .3 Operating Conditions: -4°F to 122°F, 15 to 90% RH
 - .4 Accuracy: ± 5 ppm or 5% of reading.
 - .5 Response Time: < 35 seconds for 90% step change
 - .6 Standard of Acceptance: Greystone CMD5B1000, or approved equivalent.
 - .9 Supply and install immersion water/glycol temperature sensors.
 - .1 Temperature sensor is to have a working range of -40°F to 250°F.
 - .2 Contractor to include well.
 - .3 Standard of Acceptance: Honeywell C7041D2001, or approved equivalent.
 - .10 Supply and install immersion water/glycol pressure sensors
 - .1 Pressure Range: 150 psi
 - .2 Operating Temperature: -40°F to 257°F
 - .3 Response Time: <2 ms
-

- .4 Accuracy: +/- 0.50% FSS
- .5 Standard of Acceptance: Honeywell MLH150PSM01B, or approved equivalent.

.11 Supply and install one (1) refrigerant alarm system in the refrigeration room.

- .1 Refrigerant Type: R-513A
 - .2 Enclosure: NEMA 4x with clear window
 - .3 Mounting Height: 4-5 ft above finished floor
 - .4 Operating Temperature: -4°F to 122°F
 - .5 Humidity: continuous 15 to 90% RH, non-condensing and intermittent 0 to 99% RH, non-condensing.
 - .6 Relay Contacts: Four (4) SPDT 10A @ 250 VAC Res.
 - .7 Indicators: RED LED (Alarm), Yellow LED (Warning), Green LED (Status)
 - .8 Include Concentration Display
 - .9 Include Modbus RTU connection.
 - .10 Sensor:
 - .1 Detectable Gas: R-513A
 - .2 Sensor Type: Infra-Red Temperature Controlled
 - .3 Enclosure: Polycarbonate/ABS blend
 - .4 Supply Voltage: 24 VDC, nominal range
 - .5 Operating Temperature: -49°F to 149°F
 - .6 Accuracy: ±3% of reading
 - .7 Repeatability: ±3% of full scale
 - .8 Response Time: less than 30 seconds for 90% of step change
 - .9 Standard of Acceptance: QEL QIRF-513X-0, or approved equivalent.
 - .11 System to be connected to the refrigeration room exhaust fan for automatic ventilation activation.
 - .12 Provide one (1) switch for the manual fan switch located outside the refrigeration room and connected to the controller and exhaust fan.
 - .1 Standard of Acceptance: QEL M-Switch, or approved equivalent.
 - .13 Provide one (1) switch for the manual fan switch located inside the refrigeration room and connected to the controller and exhaust fan.
 - .1 Standard of Acceptance: QEL M-Switch, or approved equivalent.
 - .14 Provide one (1) switch for the reset fan switch located inside the refrigeration room and connected to the controller and exhaust fan.
-

- .1 Standard of Acceptance: QEL M-Reset, or approved equivalent.
 - .15 Alarm system must include a strobe light inside and outside the refrigeration room.
 - .1 Standard of Acceptance: QEL M-Strobe, or approved equivalent.
 - .16 Must be ready for integration into a Building Automation System (BMS).
 - .17 Standard of Acceptance: QEL Q-Controller, or approved equivalent.
 - .12 Supply and install current transformers
 - .1 Frequency Range: 50/60 HZ.
 - .2 UL/ULC, CE listed
 - .3 Multiple selectable range split-cores
 - .4 Insulation class: 600V RMS
 - .5 Standard of Acceptance: Honeywell Senva Inc Current Transducers, or approved equivalent.
 - .13 Supply and install current transducers
 - .1 Accuracy: 2% of F.S. above 80A
 - .2 Range 0A-800A
 - .3 Type: Current Transducer, AC
 - .4 Output: 4-20 mA
 - .5 Standard of Acceptance: Veris H321, or approved equivalent.
 - .14 Supply and install power relays
 - .1 Poles: single pole per relay
 - .2 Coil volts: 24 VAC/DC
 - .3 Both AC and DC rated
 - .4 Amps: 6 A
 - .5 UL Approved only
 - .6 Standard of Acceptance: Allen-Bradley ALB700HLT1U24, or approved equivalent.
 - .15 All control systems are to include an Uninterruptable Power Supply (UPS) to prevent the control system shutting down in the event of a building power outage or fluctuations.
 - .1 Use only an industrial-grade power supply sized to provide power to all control components.
 - .2 Capacity: 300 Watts (500 VA).
 - .3 Recharge time: 8 hours to 90% capacity after full discharge.
 - .4 Typical Back-up Time: 4 minutes.
 - .5 Suitable Temperature Range: 32 – 122°F
-

- .6 Standard of Acceptance: Sola SDU 500, or approved equivalent.
- .16 Automation contractor is to supply all power wiring and control valves per this contract. 24V wiring is required for automation components.
- .17 All control wiring shall have a minimum FT-4 rating.
- .18 The Contractor of this division is required to install all noted control valves.
- .19 Contractor is to supply and install all necessary transformers and relays.

3.3 Automation System Scope of Work

- .1 General
 - .1 Contractor to provide a new automation system for additional control points with the specifications mentioned herein.
 - .2 Control system to be standalone.
 - .3 The Building Management System (BMS) shall be comprised of a network of interoperable, stand-alone digital controllers, a network area controller, graphics and programming and other control devices for a complete system as specified herein.
 - .4 The installed system shall provide secure password access to all features, functions and data contained in the overall BMS.
 - .5 Controls contractor to provide a data connection from the BMS to the I.B. Storey secure Niagara supervisory system, as well as all accessories required to provide that data connection.
 - .1 This will be coordinated with Owner's IT and Consultant.
 - .6 Standard of acceptance for Controller Vendors:
 - .1 Tridium's "JACE-8000 Niagara 4 Platform"
 - .2 Honeywell International's "WEB-8000 Niagara 4 Platform"
 - .3 Johnson Controls' "FX80 Niagara 4 Platform"
- .2 Open, Interoperable, Integrated Architecture
 - .1 The intent of this specification is to provide a peer-to-peer networked, stand-alone, distributed control system utilizing Open protocols in one open, interoperable system.
 - .2 The supplied computer software shall employ object-oriented technology (OOT) for representation of all data and control devices within the system. Physical connection of any BACnet control equipment, such as chillers, shall be via Ethernet or IP.
 - .3 All components and controllers supplied under this contract shall be true "peer-to-peer" communicating devices.

Components or controllers requiring "polling" by a host to pass data will not be acceptable.

- .4 The supplied system shall incorporate the ability to access all data using HTML5 enabled browsers without requiring proprietary operator interface and configuration programs or browser plug-ins. An Open Database Connectivity (ODBC) or Structured Query Language (SQL) compliant server database is required for all system database parameter storage. This data shall reside on the Operating System Server located in the Facilities Office on the LAN. Systems requiring proprietary database and user interface programs shall not be acceptable.
- .5 A hierarchical topology is required to assure reasonable system response times and to manage the flow and sharing of data without unduly burdening the customer's internal Intranet network. Systems employing a "flat" single tiered architecture shall not be acceptable.
 - .1 Maximum acceptable response time from any alarm occurrence (at the point of origin) to the point of annunciation shall not exceed 5 seconds for network connected user interfaces.
 - .2 Maximum acceptable response time from any alarm occurrence (at the point of origin) to the point of annunciation shall not exceed 60 seconds for remote or dial-up connected user interfaces.
- .3 BAS SERVER HARDWARE
 - .1 Minimum Computer Configuration (Hardware Independent).
 - .2 Central Server. Contractor shall provide a dedicated BAS server with configuration that includes the following components as a minimum:
 - .1 Processor: Intel Xeon CPU E5-2640 x64 (or better), compatible with dual- and quad-core processors.
 - .2 Memory: 2 GB or more recommended for large systems, 8 GB or more recommended for the Windows 64-bit version.
 - .3 Hard Drive: 4 GB minimum, more recommended depending on archiving requirements.
 - .4 Display: Video card and monitor capable of displaying 1024 x 768 pixel resolution or greater.
 - .5 Network Support: Ethernet adapter (10/100 Mb with RJ-45 connector).
 - .6 Connectivity: Full-time high-speed ISP connection recommended for remote site access (i.e. T1, ADSL, cable modem).

- .3 Standard Client: The thin-client Web Browser BAS GUI shall be Microsoft Internet Explorer (10.0 or later) running on Microsoft 7+. No special software shall be required to be installed on the PCs used to access the BAS via a web browser.
 - .4 BAS MOBILE ACCESS HMI
 - .1 Contractor is to supply and install one (1) BAS Mobile Access HMI embedded into the exterior of the control panel for full control access in the form of a commercially standard tablet with the following specifications:
 - .1 A 12" touch screen
 - .2 Run on the latest Android OS
 - .5 SYSTEM NETWORK CONTROLLER (SNC)
 - .1 These controllers are designed to manage communications between the programmable equipment controllers (PEC), application specific controllers (ASC) and advanced unitary controllers (AUC) which are connected to its communications trunks, manage communications between itself and other system network controllers (SNC) and with any operator workstations (OWS) that are part of the BAS, and perform control and operating strategies for the system based on information from any controller connected to the BAS.
 - .2 The controllers shall be fully programmable to meet the unique requirements of the facility it shall control.
 - .3 The controllers shall be capable of peer-to-peer communications with other SNC's and with any OWS connected to the BAS, whether the OWS is directly connected, connected via cellular modem or connected via the Internet.
 - .4 The communication protocols utilized for peer-to-peer communications between SNC's will be Niagara 4 Fox, BACnet TCP/IP and SNMP. Use of a proprietary communication protocol for peer-to-peer communications between SNC's is not allowed.
 - .5 The SNC shall employ a device count capacity license model that supports expansion capabilities.
 - .6 The SNC shall be enabled to support and shall be licensed with the following Open protocol drivers (client and server) by default:
 - .1 BACnet
 - .2 Lon
 - .3 MODBUS
 - .4 SNMP
 - .5 KNX
 - .7 The SNC shall be capable of executing application control programs to provide:
-

- .1 Calendar functions.
 - .2 Scheduling.
 - .3 Trending.
 - .4 Alarm monitoring and routing.
 - .5 Time synchronization.
 - .6 Integration of LonWorks, BACnet, and MODBUS controller data.
 - .7 Network management functions for all SNC, PEC and ASC based devices.
 - .8 The SNC shall provide the following hardware features as a minimum:
 - .1 Two 10/100 Mbps Ethernet ports.
 - .2 Two Isolated RS-485 ports with biasing switches.
 - .3 1 GB RAM
 - .4 4 GB Flash Total Storage / 2 GB User Storage
 - .5 Wi-Fi (Client or WAP)
 - .6 USB Flash Drive
 - .7 High Speed Field Bus Expansion
 - .8 -4-140°F Ambient Operating Temperature
 - .9 Integrated 24 VAC/DC Global Power Supply
 - .10 MicroSD Memory Card Employing Encrypted Safe Boot Technology
 - .9 The SNC shall support standard Web browser access via the Intranet/Internet. It shall support a minimum of 16 simultaneous users.
 - .10 The SNC shall provide alarm recognition, storage, routing, management and analysis to supplement distributed capabilities of equipment or application specific controllers.
 - .11 The SNC shall be able to route any alarm condition to any defined user location whether connected to a local network or remote via cellular modem, or wide-area network.
 - .1 Alarm generation shall be selectable for annunciation type and acknowledgement requirements including but not limited to:
 - .1 Alarm.
 - .2 Return to normal.
 - .3 To default.
 - .2 Alarms shall be annunciated in any of the following manners as defined by the user:
 - .1 Screen message text.
 - .2 Email of complete alarm message to multiple recipients.
 - .3 Pagers via paging services that initiate a page on receipt of email message.
-

- .4 Graphics with flashing alarm object(s).
 - .3 The following shall be recorded by the SNC for each alarm (at a minimum):
 - .1 Time and date.
 - .2 Equipment (air handler #, access way, etc.).
 - .3 Acknowledge time, date, and user who issued acknowledgement.
 - .12 Programming software and all controller "Setup Wizards" shall be embedded into the SNC.
 - .13 The SNC shall support the following security functions.
 - .1 Module code signing to verify the author of programming tool and confirm that the code has not been altered or corrupted.
 - .2 Role-Based Access Control (RBAC) for managing user roles and permissions.
 - .3 Require users to use strong credentials.
 - .4 Data in Motion and Sensitive Data at Rest be encrypted.
 - .14 LDAP and Kerberos integration of access management. The SNC shall support the following data modeling structures to utilize Search; Hierarchy; Template; and Permission functionality:
 - .1 Metadata: Descriptive tags to define the structure of properties.
 - .2 Tagging: Process to apply metadata to components
 - .3 Tag Dictionary
 - .15 The SNC shall employ template functionality. Templates are a containerized set of configured data tags, graphics, histories, alarms... that are set to be deployed as a unit based upon manufacturer's controller and relationships. All lower level communicating controllers (PEC, AUC, AVAV, VFD...) shall have an associated template file for reuse on future project additions.
 - .16 The SNC shall be provided with a 5 Year Software Maintenance license. Labour to implement not included.
 - .6 Programmable Equipment Controller (PEC)
 - .1 Equipment control shall be accomplished using LonMark or BACnet based devices where the application has a LonMark profile or BTL Listed PICS defined. Where LonMark devices are not available for a particular application, devices based on LonWorks shall be acceptable. For each LonWorks device that does not have LonMark certification, the device supplier shall provide an XIF file for the device. The controller platform shall provide options and advanced system functions, programmable and configurable using Niagara 4 Framework, that allow
-

- standard and customizable control solutions required in executing the "Sequence of Operation".
- .2 All PECs shall be application programmable and shall at all times maintain their certification. All control sequences within or programmed into the PEC shall be stored in non-volatile memory, which is not dependent upon the presence of a battery to be retained.
 - .3 The PEC shall provide LED indication of communication and controller performance to the technician, without cover removal.
 - .4 The PEC shall not require any external configuration tool or programming tool. All configuration and programming tasks shall be accomplished and accessible from within the Niagara 4 environment.
 - .5 The following integral and remote Inputs/Outputs shall be supported per each PEC:
 - .1 Eight integral dry contact digital inputs.
 - .2 Any two digital inputs may be configured as pulse counters with a maximum pulse read rate of 15 Hz.
 - .3 Eight integral analog inputs (configurable as 0-10V, 0-10,000 Ohm or, 20K NTC).
 - .4 Six integral 4-20 mA analog outputs.
 - .5 Eight integral 24 Vac Triac digital outputs, configurable as maintained or floating motor control outputs.
 - .6 One integral 20 Vdc, 65-mA power supply for auxiliary devices.
 - .7 If a 20 Vdc 65-mA power supply terminal is not integral to the PEC, provide at each PEC a separate, fully isolated, enclosed, current limited and regulated UL listed auxiliary power supply for power to auxiliary devices.
 - .6 Each PEC shall have expansion ability to support additional I/O requirements through the use of remote input/output modules.
 - .7 PEC Controllers shall support at minimum the following control techniques:
 - .1 General-purpose control loops that can incorporate Demand Limit Control strategies, Set point reset, adaptive intelligent recovery, and time of day bypass.
 - .2 General-purpose, non-linear control loops.
 - .3 Start/stop Loops.
 - .4 If/Then/Else logic loops.
 - .5 Math Function loops (MIN, MAX, AVG, SUM, SUB, SQRT, MUL, DIV, ENTHALPY)
-

.7 BAS Server & Web Browser GUI - System Overview

- .1 The BAS Contractor shall provide system software based on server/thin-client architecture, designed around the open standards of web technology. The BAS server shall communicate using Ethernet and TCP. Server shall be accessed using a web browser over Owner intranet and remotely over the Internet.
 - .2 The intent of the thin-client architecture is to provide the operator(s) complete access to the BAS system via a web browser. The thin-client web browser Graphical User Interface (GUI) shall be browser and operating system agnostic, meaning it will support HTML5 enabled browsers without requiring proprietary operator interface and configuration programs or browser plug-ins. Microsoft, Firefox, and Chrome browsers (current released versions), and Windows as well as non-Windows operating systems.
 - .3 The BAS server software shall support at least the following server platforms (Windows 7, 8.1, Server 12). The BAS server software shall be developed and tested by the manufacturer of the system stand-alone controllers and network controllers/routers.
 - .4 The web browser GUI shall provide a completely interactive user interface and shall provide a HTML5 experience that supports the following features as a minimum:
 - .1 Trending.
 - .2 Scheduling.
 - .3 Electrical demand limiting.
 - .4 Duty Cycling.
 - .5 Downloading Memory to field devices.
 - .6 Real time 'live' Graphic Programs.
 - .7 Tree Navigation.
 - .8 Parameter change of properties.
 - .9 Set point adjustments.
 - .10 Alarm / event information.
 - .11 Configuration of operators.
 - .12 Execution of global commands.
 - .13 Add, delete, and modify graphics and displayed data.
 - .5 Software Components: All software shall be the most current version. All software components of the BAS system software shall be provided and installed as part of this project. BAS software components shall include:
 - .1 Server Software, Database and Web Browser Graphical User Interface.
-

- .2 5 Year Software Maintenance license. Labour to implement not included.
 - .3 Embedded System Configuration Utilities for future modifications to the system and controllers.
 - .4 Embedded Graphical Programming Tools.
 - .5 Embedded Direct Digital Control software.
 - .6 Embedded Application Software.
 - .6 BAS Server Database: The BAS server software shall utilize a Java Database Connectivity (JDBC) compatible database such as: MS SQL 8.0, Oracle 8i or IBM DB2. BAS systems written to Non -Standard and/or Proprietary databases are NOT acceptable.
 - .7 Thin Client - Web Browser Based: The GUI shall be thin client or browser based and shall meet the following criteria:
 - .1 Web Browser's for PC's: Only the current released browser (Explorer/Firefox/Chrome) will be required as the GUI and a valid connection to the server network. No installation of any custom software shall be required on the operator's GUI workstation/client. Connection shall be over an intranet or the Internet.
 - .2 Secure Socket Layers: Communication between the Web Browser GUI and BAS server shall offer encryption using 128-bit encryption technology within Secure Socket Layers (SSL). Communication protocol shall be Hyper-Text Transfer Protocol (HTTP).
 - .8 Web Browser Graphical User Interface
 - .1 Web Browser Navigation: The Thin Client web browser GUI shall provide a comprehensive user interface. Using a collection of web pages, it shall be constructed to "feel" like a single application, and provide a complete and intuitive mouse/menu driven operator interface. It shall be possible to navigate through the system using a web browser to accomplish requirements of this specification. The Web Browser GUI shall (as a minimum) provide for navigation, and for display of animated graphics, schedules, alarms/events, live graphic programs, active graphic set point controls, configuration menus for operator access, reports and reporting actions for events.
 - .2 Login: On launching the web browser and selecting the appropriate domain name or IP address, the operator shall be presented with a login page that will require a login name and strong password. Navigation in the system shall be dependent on the operator's role-based application control privileges.
-

- .3 Navigation: Navigation through the GUI shall be accomplished by clicking on the appropriate level of a navigation tree (consisting of an expandable and collapsible tree control like Microsoft's Explorer program) and/or by selecting dynamic links to other system graphics. Both the navigation tree and action pane shall be displayed simultaneously, enabling the operator to select a specific system or equipment and view the corresponding graphic. The navigation tree shall as a minimum provide the following views: Geographic, Network, Groups and Configuration.
 - .1 Geographic View shall display a logical geographic hierarchy of the system including: cities, sites, buildings, building systems, floors, equipment and objects.
 - .2 Groups View shall display Scheduled Groups and custom reports.
 - .3 Configuration View shall display all the configuration categories (Operators, Schedule, Event, Reporting and Roles).
 - .4 Action Pane: The Action Pane shall provide several functional views for each subsystem specified. A functional view shall be accessed by clicking on the corresponding button:
 - .1 Graphics: Using graphical format suitable for display in a web browser, graphics shall include aerial building/campus views, color building floor-plans, equipment drawings, active graphic set point controls, web content and other valid HTML elements. The data on each graphic page shall automatically refresh.
 - .2 Dashboards: User customizable data using drag and drop HTML5 elements. Shall include Web Charts, Gauges, and other custom developed widgets for web browser. User shall have ability to save custom dashboards.
 - .3 Search: User shall have multiple options for searching data based upon Tags. Associated equipment, real time data, Properties, and Trends shall be available in result.
 - .4 Properties: Shall include graphic controls and text for the following: Locking or overriding objects, demand strategies, and any other valid data required for setup. Changes made to the properties pages shall require the operator to depress an 'accept/cancel' button.
 - .5 Schedules: Shall be used to create, modify/edit and view schedules based on the systems hierarchy (using the navigation tree).
-

- .6 Alarms: Shall be used to view alarm information geographically (using the navigation tree), acknowledge alarms, sort alarms by category, actions and verify reporting actions.
 - .7 Charting: Shall be used to display associated trend and historical data, modify colors, date range, axis and scaling. User shall have ability to create HTML charts through web browser without utilizing chart builder. User shall be able to drag and drop single or multiple data points, including schedules, and apply status colors for analysis.
 - .8 Logic - Live Graphic Programs: Shall be used to display 'live' graphic programs of the control algorithm, (micro block programming) for the mechanical/electrical system selected in the navigation tree.
 - .9 Other actions such as Print, Help, Command, and Logout shall be available via a drop-down window.
 - .5 Color Graphics: The Web Browser GUI shall make extensive use of color in the graphic pane to communicate information related to set points and comfort. Animated .gifs or .jpg, vector scalable, active set point graphic controls shall be used to enhance usability. Graphics tools used to create Web Browser graphics shall be non-proprietary and conform to the following basic criteria:
 - .1 Display Size: The GUI workstation software shall graphically display in a minimum of 1024 by 768 pixels 24 bit True Color.
 - .2 General Graphic: General area maps shall show locations of controlled buildings in relation to local landmarks.
 - .3 Color Floor Plans: Floor plan graphics shall show heating and cooling zones throughout the buildings in a range of colors, as selected by Owner. Provide a visual display of temperature relative to their respective set points. The colors shall be updated dynamically as a zone's actual comfort condition changes.
 - .4 Mechanical Components: Mechanical system graphics shall show the type of mechanical system components serving any zone through the use of a pictorial representation of components. Selected I/O points being controlled or monitored for each piece of equipment shall be displayed with the appropriate engineering units. Animation shall be used for rotation or moving mechanical components to enhance usability.
 - .5 Minimum System Color Graphics: Color graphics shall be selected and displayed via a web browser for the following:
-

- .1 Each piece of equipment monitored or controlled including each terminal unit.
 - .2 Each building.
 - .3 Each floor and zone controlled.
- .6 Hierarchical Schedules: Utilizing the Navigation Tree displayed in the web browser GUI, an operator (with proper access credentials) shall be able to define a Normal, Holiday or Override schedule for an individual piece of equipment or room, or choose to apply a hierarchical schedule to the entire system, site or floor area. For example, Independence Day 'Holiday' for every level in the system would be created by clicking at the top of the geographic hierarchy defined in the Navigation Tree. No further operator intervention would be required and every control module in the system with would be automatically downloaded with the ' Independence Day' Holiday. All schedules that affect the system/area/equipment highlighted in the Navigation Tree shall be shown in a summary schedule table and graph.
 - .1 Schedules: Schedules shall comply with the LonWorks and BACnet standards, (Schedule Object, Calendar Object, Weekly Schedule property and Exception Schedule property) and shall allow events to be scheduled based on:
 - .1 Types of schedule shall be Normal, Holiday or Override.
 - .2 A specific date.
 - .3 A range of dates.
 - .4 Any combination of Month of Year (1-12, any), Week of Month (1-5, last, any), Day of Week (M-Sun, Any).
 - .5 Wildcard (example, allow combinations like second Tuesday of every month).
 - .2 Schedule Categories: The system shall allow operators to define and edit scheduling categories (different types of "things" to be scheduled; for example, lighting, HVAC occupancy, etc.). The categories shall include: name, description, icon (to display in the hierarchy tree when icon option is selected) and type of value to be scheduled.
 - .3 Schedule Groups: In addition to hierarchical scheduling, operators shall be able to define functional Schedule Groups, comprised of an arbitrary group of areas/rooms/equipment scattered throughout the facility and site. For example, the operator shall be able to define an ' individual tenant' group - who may occupy different areas within a building or buildings. Schedules applied to the ' tenant group' shall automatically be downloaded to

control modules affecting spaces occupied by the 'tenant group'.

- .4 Intelligent Scheduling: The control system shall be intelligent enough to automatically turn on any supporting equipment needed to control the environment in an occupied space. If the operator schedules an individual room in a VAV system for occupancy, for example, the control logic shall automatically turn on the VAV air handling unit, chiller, boiler and/or any other equipment required to maintain the specified comfort and environmental conditions within the room.
 - .5 Partial Day Exceptions: Schedule events shall be able to accommodate a time range specified by the operator (ex: board meeting from 6 pm to 9 pm overrides Normal schedule for conference room).
 - .6 Schedule Summary Graph: The schedule summary graph shall clearly show Normal versus Holiday versus Override Schedules and the net operating schedule that results from all contributing schedules. Note: In case of priority conflict between schedules at the different geographic hierarchy, the schedule for the more detailed geographic level shall apply.
 - .7 Alarms: Alarms associated with a specific system, area, or equipment selected in the Navigation Tree, shall be displayed in the Action Pane by selecting an 'Alarms' view. Alarms, and reporting actions shall have the following capabilities:
 - .8 Alarms View: Each Alarm shall display an Alarms Category (using a different icon for each alarm category), date/time of occurrence, current status, alarm report and a bold URL link to the associated graphic for the selected system, area or equipment. The URL link shall indicate the system location, address and other pertinent information. An operator shall easily be able to sort events, edit event templates and categories, acknowledge or force a return to normal in the Events View as specified in this section.
 - .9 Alarm Categories: The operator shall be able to create, edit or delete alarm categories such as HVAC, Maintenance, Fire, or Generator. An icon shall be associated with each alarm category, enabling the operator to easily sort through multiple events displayed.
 - .10 Alarm Templates: Alarm template shall define different types of alarms and their associated properties. As a
-

minimum, properties shall include a reference name, verbose description, severity of alarm, acknowledgement requirements, and high/low limit and out of range information.

- .11 Alarm Areas: Alarm Areas enable an operator to assign specific Alarm Categories to specific Alarm Reporting Actions. For example, it shall be possible for an operator to assign all HVAC Maintenance Alarm on the 1st floor of a building to email the technician responsible for maintenance. The Navigation Tree shall be used to setup Alarm Areas in the Graphic Pane.
 - .12 Alarm Time/Date Stamp: All events shall be generated at the DDC control module level and comprise the Time/Date Stamp using the standalone control module time and date.
 - .13 Alarm Configuration: Operators shall be able to define the type of Alarm generated per object. A 'network' view of the Navigation Tree shall expose all objects and their respective Alarm Configuration. Configuration shall include assignment of Alarm, type of Acknowledgement and notification for return to normal or fault status.
 - .14 Alarm Summary Counter: The view of Alarm in the Graphic Pane shall provide a numeric counter, indicating how many Alarms are active (in alarm), require acknowledgement and total number of Alarms in the BAS Server database.
 - .15 Alarm Auto-Deletion: Alarms that are acknowledged and closed shall be auto-deleted from the database and archived to a text file after an operator defined period.
 - .16 Alarm Reporting Actions: Alarm Reporting Actions specified shall be automatically launched (under certain conditions) after an Alarm is received by the BAS server software. Operators shall be able to easily define these Reporting Actions using the Navigation Tree and Graphic Pane through the web browser GUI. Reporting Actions shall be as follows:
 - .1 Print: Alarm information shall be printed to the BAS server's PC or a networked printer.
 - .2 Email: Email shall be sent via any POP3-compatible e-mail server (most Internet Service Providers use POP3). Email messages may be copied to several email accounts. Note: Email reporting action shall also be used to support alphanumeric paging services, where email servers support pagers.
 - .3 File Write: The ASCII File write reporting action shall enable the operator to append operator defined alarm
-

information to any alarm through a text file. The alarm information that is written to the file shall be completely definable by the operator. The operator may enter text or attach other data point information (such as AHU discharge temperature and fan condition upon a high room temperature alarm).

- .4 Write Property: The write property reporting action updates a property value in a hardware module.
 - .5 SNMP: The Simple Network Management Protocol (SNMP) reporting action sends an SNMP trap to a network in response to receiving an alarm.
 - .6 Run External Program: The Run External Program reporting action launches specified program in response to an event.
- .7 Trends: As system is engineered, all points shall be enabled to trend. Trends shall both be displayed and user configurable through the Web Browser GUI. Trends shall comprise analog, digital or calculated points simultaneously. A trend log's properties shall be editable using the Navigation Tree and Graphic Pane.
- .1 Viewing Trends: The operator shall have the ability to view trends by using the Navigation Tree and selecting a Trends button in the Graphic Pane. The system shall allow y- and x-axis maximum ranges to be specified and shall be able to simultaneously graphically display multiple trends per graph.
 - .2 Local Trends: Trend data shall be collected locally by Multi-Equipment/Single Equipment general-purpose controllers, and periodically uploaded to the BAS server if historical trending is enabled for the object. Trend data, including run time hours and start time date shall be retained in non-volatile module memory. Systems that rely on a gateway/router to run trends are NOT acceptable.
 - .3 Resolution. Sample intervals shall be as small as one second. Each trended point will have the ability to be trended at a different trend interval. When multiple points are selected for displays that have different trend intervals, the system will automatically scale the axis.
 - .4 Dynamic Update. Trends shall be able to dynamically update at operator-defined intervals.
-

- .5 Zoom/Pan. It shall be possible to zoom-in on a particular section of a trend for more detailed examination and 'pan through' historical data by simply scrolling the mouse.
 - .6 Numeric Value Display. It shall be possible to pick any sample on a trend and have the numerical value displayed.
 - .7 Copy/Paste. The operator shall have the ability to pan through a historical trend and copy the data viewed to the clipboard using standard keystrokes (i.e. CTRL+C, CTRL+V).
 - .8 Security Access: Systems that Security access from the web browser GUI to BAS server shall require a Login Name and Strong Password. Access to different areas of the BAS system shall be defined in terms of Role-Based Access Control privileges as specified:
 - .1 Roles: Roles shall reflect the actual roles of different types of operators. Each role shall comprise a set of 'easily understood English language' privileges. Roles shall be defined in terms of View, Edit and Function Privileges.
 - .1 View Privileges shall comprise: Navigation, Network, and Configuration Trees, Operators, Roles and Privileges, Alarm/Event Template and Reporting Action.
 - .2 Edit Privileges shall comprise: Set point, Tuning and Logic, Manual Override, and Point Assignment Parameters.
 - .3 Function Privileges shall comprise: Alarm/Event Acknowledgement, Control Module Memory Download, Upload, Schedules, Schedule Groups, Manual Commands, Print and Alarm/Event Maintenance.
 - .2 Geographic Assignment of Roles: Roles shall be geographically assigned using a similar expandable/collapsible navigation tree. For example, it shall be possible to assign two HVAC Technicians with similar competencies (and the same operator defined HVAC Role) to different areas of the system.
 - .9 Graphical Programming
 - .1 The system software shall include a Graphic Programming Language (GPL) for all DDC control algorithms resident in all control modules. Any system that does not use a drag and drop method of graphical icon programming shall not be accepted. All systems shall use a GPL method used to create a sequence of operations by assembling graphic microblocks that represent each of the commands or functions necessary to complete a control sequence. Microblocks represent common logical control devices used in conventional control systems, such as
-

relays, switches, high signal selectors etc., in addition to the more complex DDC and energy management strategies such as PID loops and optimum start. Each microblock shall be interactive and contain the programming necessary to execute the function of the device it represents.

- .2 Graphic programming shall be performed while on screen and using a mouse; each microblock shall be selected from a microblock library and assembled with other microblocks necessary to complete the specified sequence. Microblocks are then interconnected on screen using graphic "wires," each forming a logical connection. Once assembled, each logical grouping of microblocks and their interconnecting wires then forms a graphic function block which may be used to control any piece of equipment with a similar point configuration and sequence of operation.
 - .3 Graphic Sequence: The clarity of the graphic sequence shall be such that the operator has the ability to verify that system programming meets the specifications, without having to learn or interpret a manufacturer's unique programming language. The graphic programming shall be self-documenting and provide the operator with an understandable and exact representation of each sequence of operation.
 - .4 GPL Capabilities: The following is a minimum definition of the capabilities of the Graphic Programming software:
 - .1 Function Block (FB): Shall be a collection of points, microblocks and wires which have been connected together for the specific purpose of controlling a piece of HVAC equipment or a single mechanical system.
 - .2 Logical I/O: Input/Output points shall interface with the control modules in order to read various signals and/or values or to transmit signal or values to controlled devices.
 - .3 Microblocks: Shall be software devices that are represented graphically and may be connected together to perform a specified sequence. A library of microblocks shall be submitted with the control contractors bid.
 - .4 Wires: Shall be Graphical elements used to form logical connections between microblocks and between logical I/O.
 - .5 Reference Labels: Labels shall be similar to wires in that they are used to form logical connections between two points. Labels shall form a connection by reference instead of a visual connection, i.e. two points labeled 'A' on a drawing are logically connected even though there is no wire between them.
-

- .6 Parameter: A parameter shall be a value that may be tied to the input of a microblock.
- .7 Properties: Dialog boxes shall appear after a microblock has been inserted which has editable parameters associated with it. Default parameter dialog boxes shall contain various editable and non-editable fields, and shall contain 'push buttons' for the purpose of selecting default parameter settings.
- .8 Icon: An icon shall be graphic representation of a software program. Each graphic microblock has an icon associated with it that graphically describes its function.
- .9 Menu-bar Icon: Shall be an icon that is displayed on the menu bar on the GPL screen, which represents its associated graphic microblock.
- .10 Live Graphical Programs: The Graphic Programming software shall support a 'live' mode, where all input/output data, calculated data and set points shall be displayed in a 'live' real-time mode.
- .10 LONWORKS Network Management
 - .1 Systems requiring the use of third-party LonWorks network management tools shall not be accepted.
 - .2 Network management shall include the following services: device identification, device installation, device configuration, device diagnostics, device maintenance and network variable binding.
 - .3 The Network configuration tool shall also provide diagnostics to identify devices on the network, to reset devices and to view health and status counters within devices.
 - .4 These tools shall provide the ability to "learn" an existing LonWorks network, regardless of what network management tool(s) were used to install the existing network, so that existing LonWorks devices and newly added devices are part of a single network management database.
 - .5 The network management database shall be resident in the Network Area Controller (NAC), ensuring that anyone with proper authorization has access to the network management database at all times. Systems employing network management databases that are not resident, at all times and within the control system shall not be accepted

3.4 Additional Automation
Items

- .1 Any electrical or fire alarm shutdowns required by the Contractor for the scope of work must be approved by the Owner two (2) weeks prior to being performed for coordination purposes.

- .2 All valves and controls should be located at ergonomic heights unless technically unfeasible.
 - .3 All equipment installations must be constructed in conformance with the all local, state, and national code. Any additional requirements from the latest codes and standards supersede any requirements as written in this document.
 - .4 All equipment shall be installed such that it meets or exceeds the manufacturer's recommended installation practices and requirements.
 - .5 There will be a \$5,000 cash allowance for IT Infrastructure to be coordinated with the Consultant.
 - .6 The automation contractor must have a service staff member with spare components available no more than a 4-hour transport distance from the facility for emergency repairs or adjustments.
 - .7 The automation contractor must provide the Consultant with remote user access to the automation system. The remote user access must include control functionality such that changes may be made to setpoints or schedules as needed.
 - .8 Power and control wiring as much as possible is to be run through the building in non-accessible locations to the buildings occupants in the most aesthetically pleasing method as reasonable.
 - .1 Power and control wiring shall be run in conduit as much as possible.
 - .2 Power and control wiring shall be firmly secured to surfaces, walls, cable trays, or other.
 - .3 Power and control wiring is to be run parallel along walls at a minimum elevation of 7 ft in occupied corridors or along the ceiling of these zones to prevent interference with building occupants.
 - .9 The automation contractor is responsible for performing a full operational test of the automation and controls system in manual (backup) mode to ensure full functionality of the system.
 - .10 All automation valves equipped with actuators shall feature position feedback functionality.
-

PART 4 – ICE RINK FLOOR

4.1 Ice Rink Floor Description

- .1 Demolish the existing cold floors including header pipes.
- .2 The supply and installation of floor materials and piping systems as outlined.
- .3 Coordinate installation of the Dasher Board System anchors with the Dasher Board System installer.
- .4 The intent of this upgrade is to install two (2) ice surfaces with NHL regulation playing surface size of 200 ft. x 85 ft. with corner radii of 28 ft.
- .5 Provide a complete, neat and workmanlike installation.

4.2 Ice Rink Floor Submittals

- .1 No material orders or work will begin on any segment of this scope of work until submittals have been successfully reviewed and approved for conformity with these specifications and the design intent.
- .2 Submit data for each accessory, admixtures, and curing material for the work.
- .3 Concrete Design Data:
 - .1 Prior to the Work, the Contractor must submit the mix design and batch plans for review and approval.
 - .2 Submit test results of proposed mix design, performed locally, two (2) months prior to use for approval by the Consultant.
 - .3 Submit all certificates for cement, fly ash, and all aggregates.
- .4 Shop Drawings:
 - .1 Contractor must submit shop drawings for all products including, but not limited to: piping, pipe chairs, pipe bends, concrete, rebar, wire mesh, insulation, and expansion joints.
 - .2 Shop drawing documents must indicate procedures, schedules, equipment, and all components required for the rink floor.
 - .3 Contractor to include specifications of the anti-freeze mixtures.
 - .4 Test results of the concrete mixture to be installed.

4.3 Ice Rink Floor Codes and Standards

- .1 The Contractor shall fully comply with all codes and standards applicable to the Work undertaken, including but not limited to:
 - .1 ACI 311-4R-09 Guide for Concrete Inspection.
 - .2 ACI 302.1R-15
-

- .3 ACI 301-20 Specifications for Concrete Construction
- .4 ASTM E1745-17 Standard Specification for Plastic Water Vapor Retarders Used in Contact with Soil or Granular Fill under Concrete Slabs.
- .5 ASTM C0578-22 Standard Specification for Rigid, Cellular Polystyrene Thermal Insulation
- .6 ASTM E1155M – Standard Test Method for Determining F_F Floor Flatness and F_F Floor Levelness Numbers.
- .2 In the case of conflicts or discrepancies, the more stringent regulation shall apply.
- .3 All Work shall meet the approval of the Authorities Having Jurisdiction at the project site.

4.4 Ice Rink Floor Scope of Work

- .1 This section describes the construction of a single ice rink floor. The construction of two (2) ice rink floors is required under this scope of work.
 - .2 Perform a survey of each of the two (2) existing ice rink floors prior to demolition.
 - .1 Work to be completed by a professional survey engineer licensed in the State of Illinois.
 - .2 The intent is to confirm exact dimensions of the existing ice rink floors.
 - .3 Remove and dispose of the existing ice rink floors and header systems. Excavate the existing rink floors down to the depths specified in the drawings package.
 - .4 Coordinate all work with the dasher board system installer including the placement of dasher board anchors and goal post inserts.
 - .5 The new ice surface must encompass a playing area 200' x 85, with 28' corner radii.
 - .1 Finished rink floor slab surface to be flush with perimeter finished slab, on parallel planes.
 - .2 All assemblies are to be rigidly secured and incapable of movement during operation.
 - .3 Floor is to be entirely free from debris before and after the concrete pour. This includes construction waste including, but not limited to, discarded sections of pipe, extra/broken/cut cable ties or tie wires, cut sections of wire mesh or rebar, and other building materials.
-

.6 Buried Mains:

- .1 Excavate or leave open the header path in the rink zone for installation then bury the header mains after installation.
- .2 Run slab sensor conduit along the buried mains path, next to pipe runs.
- .3 Cold Floor Mains:
 - .1 Supply and install two (2) pipes for the cold floor mains, supply and return, from the buried header piping to the refrigeration plant room and connecting inside the plant room.
 - .2 Provide 1" Armacell insulation and PVC jacketing for cold floor mains outside the rink slab, including the cold floor pump, up to the chiller.
 - .3 Pipe Specification: 8" HDPE SDR 11, fusion welded.
- .4 Warm Floor Mains
 - .1 Supply and install two (2) pipes for the warm floor mains, supply and return, from the buried header piping to the refrigeration plant room and connecting inside the plant room.
 - .2 Pipe Specification: 3" HDPE SDR 11, fusion welded.

.7 Buried Header Pipes:

- .1 Cold Floor Header:
 - .1 Supply and install new HDPE cold floor headers for the ice surface.
 - .1 Provide cold fluid supply and return headers
 - .2 Pipe size: 8" SDR 11
 - .3 Pipe material: HDPE
 - .4 Floor pipe connections:
 - .1 To be 1" IPS Fusion service saddle.
 - .2 All saddles to be fusion welded to headers.
 - .2 Cold floor piping to be fusion welded to the cold floor saddles.
 - .3 Contractor to supply and install two (2) drains, complete with valves, and two (2) purge valves (vent) with connections, one (1) per header.
 - .1 Provide 1" purge valves at both ends of supply and return headers.
 - .2 Connect purge valves to headers using 1" SDR 13.5 HDPE pipe. Saddles are also an approved equivalent.

- .3 Purge valve piping must not slope downwards to ensure air is not trapped in the line, and the valves must be installed in the access box.
 - .4 Supply and install deck board and Unistrut assembly support for the cold floor headers.
 - .1 Assembly to consist of 5/4" (1.25") x 6" deckboard and 1 5/8" Unistrut.
 - .2 Space every 4'
 - .3 Provide pipe clamps to clamp headers to support assembly at every other support.
 - .4 Grout down support assembly before pour.
 - .2 Warm Floor Stubby Header:
 - .1 Supply and install two (2) 3" HDPE supply and return header pipes, circulating warmed fluid to prevent frost heaving in the rink floor. Header pipes shall be run from the refrigeration room.
 - .2 Includes thirteen (13) sets of fusion service saddle connections fusion welded to each of the stubby headers.
 - .3 Contractor to supply and install two (2) drains, complete with valves, and two (2) purge valves (vent) with connections, one (1) per header.
 - .1 Provide 1" purge valves at both ends of supply and return headers.
 - .2 Connect purge valves to headers using 1" SDR 13.5 HDPE pipe. Saddles are also an approved equivalent.
 - .3 Purge valve piping must not slope downwards to ensure air is not trapped in the line, and the valves must be installed in the access box.
 - .4 All valves to be of steel bodies and be fitted with hand wheels (grips).
 - .3 Supply and install Pipe Saddles.
 - .1 To be installed to connect the floor piping to the header pipes below grade.
 - .2 Saddle: 1" IPS Fusion Service Saddles.
 - .3 Fuse 7" on center.
 - .4 All cable ties mentioned in this scope of work will conform to the following:
 - .1 Material: Nylon
 - .2 Colour: High Visibility Yellow
 - .3 All cable ties must bend down and away from rink pipes.
-

- .4 Cut all loose ends after installation and prior to the concrete pour.
 - .5 All tie wires mentioned in this scope of work will conform to the following:
 - .1 Material: Hot dipped galvanized.
 - .2 Colour: High-visibility green
 - .3 Manufactured from soft annealed wire.
 - .4 All tie wires must bend down and away from rink pipes.
 - .5 Cut all loose ends after installation and prior to the concrete pour.
 - .6 Under no circumstances must loose-ends be long enough to reach or potentially puncture the vapour barrier.
 - .7 To be used to secure all joints of interfacing meshes and rebar.
 - .6 Provide pipe supports for the buried headers along the width of the rink.
 - .1 Supports to consist of welded uni-strut assemblies secured with channel nuts to header support assembly.
 - .2 Support frame to be provided every 4' at every header support assembly.
 - .3 Cable tie each chair to horizontal strut support two pipe chairs before chair ends. No overlapping of pipe chairs is required at the buried header sections.
 - .8 Supply and install pipe sleeves for all pipes penetrating perimeter concrete.
 - .1 Use only PVC pipe sleeves.
 - .9 Cold Floor Piping
 - .1 Supply and install cold floor piping, both supply and return running parallel to each other and connected to each header saddle. To run along entire length and width of the rink.
 - .2 Piping Size: 1" SDR 13.5
 - .3 Material: HDPE
 - .4 Spaced 3 ½" on center.
 - .5 Header connections: All joints to be fully fusion welded to header saddles.
 - .6 Perimeter chill ring to be secured to the rebar reinforcements with cable ties.
 - .1 The chill ring will conform to all specifications noted above and be connected to the headers.
-

- .2 Cable ties to be provided as required to ensure no movement of the chill rings, maximum 24" apart.
 - .7 Return bends: Pre-manufactured 1" IPS Socket Fusion 180° (degree) U-bend (one-piece).
 - .1 Joints to be fully fusion welded.
 - .2 U-bend to meet SDR 13.5 dimensional requirements at minimum.
 - .3 Tension the return bends using cable ties to the perimeter rebar at rink ends to prevent sagging.
 - .8 To prevent wear, piping and bends, with exception to the chill ring, are not permitted to be in contact with the reinforcing rebar at any point.
 - .10 Warm Floor Piping
 - .1 Supply and install warm floor piping, both supply and return piping running parallel to each other and connected to each header nipple. Piping must extend the entire length and width of the new ice slab structure. Fusion service saddles may also be used.
 - .2 Pipe Size: 1" SDR 13.5
 - .3 Material: HDPE
 - .4 Spaced 24" on center.
 - .5 Provide rigid insulation to warm floor piping only located in the access box.
 - .6 Header connections: All joints to be fully fusion welded to stubby header in the access box.
 - .11 Supply and install the new Rink Floor, from base up as described below. Note the specifications for each point are described in this document.
 - .1 Clean Sand.
 - .2 Warm floor piping.
 - .3 Vapour Barrier.
 - .4 Two layers of Rigid Extruded Insulation.
 - .5 Vapour Barrier.
 - .6 Pipe Chairs (Supports).
 - .7 Bottom Lower Layer of Reinforcing Bar (Rebar)
 - .1 Installed perpendicular to cold floor piping.
 - .8 Bottom Upper Layer of Reinforcing Bar (Rebar)
 - .1 Installed parallel to cold floor piping.
 - .9 Cold Floor Piping.
 - .10 Top Layer of Reinforcing Wire Mesh.
 - .11 Concrete Slab.
-

- .1 Encapsulating the pipe chairs, pipes, and reinforcement.
 - .12 Supply and install a Clean Sand Layer
 - .1 7" total of clean sand, levelled to a $\pm 3/16$ " tolerance.
 - .2 Warm floor piping to be placed on 2" of compacted sand, then buried under a layer of 5" of sand (for a total of 7" of the sand layer).
 - .3 Sand to be free from clay, shale, and organic matter.
 - .13 Supply and install Vapour Barrier Layers
 - .1 To consist of (2) layers of 10 MIL polyethylene vapour barriers, one (1) above the clean sand level and one (1) above the rigid extruded insulation.
 - .2 Overlap the edges by minimum 12". All joints to be sealed by taping as per manufacturer's requirements.
 - .14 Supply and install Rigid Extruded Insulation.
 - .1 Provide two (2) layers of insulation between the vapour barriers.
 - .2 Thickness: 2" per layer to a total of 4"
 - .3 Compressive Strength: Minimum 30 PSI in conformance to ATSM D1621.
 - .4 Material: Thick rigid extruded insulation levelled to $\pm 3/16$ " tolerance.
 - .1 Edges of the top layer shall be staggered from the bottom layer's edges.
 - .5 Minimum Thermal Resistance: R5.
 - .6 All sheets must be laid flush.
 - .7 Standard of Acceptance: Styrofoam Brand SM Extruded Polystyrene Foam Insulation, or approved equivalent.
 - .15 Supply and install new Pipe Chairs:
 - .1 "M" style chairs with slots for tubing and supports for rebar (parallel to rink pipe) with continuous metal base.
 - .2 Material: Cold rolled steel.
 - .3 Pipe Size: 1" SDR 13.5, with 1 3/8" OD.
 - .4 Pipe centers: 3 1/2"
 - .5 20 tube slots per support.
 - .6 Total Height: 3 1/2"
 - .7 Pipe lift: 2.00"
 - .8 Rebar lift: 1.50"
 - .9 Base plates: 3" x 24 gauge spaced 36" on center.
-

- .10 Cold floor pipes to be secured to the pipe chairs at every second joint using nylon cable ties to sufficiently fasten the pipes to the chairs. Piping must lay snug in the chairs.
 - .11 Space pipe chairs, in parallel, at most 36" along the length of the rink.
 - .1 Provide a row of pipe chairs at each edge.
 - .12 Cut loose cable tie ends and dispose prior to pour.
 - .13 Overlap pipe chair ends by two (2) pipe spaces.
 - .14 Provide additional small chair sections as needed to support pipes in the edges and corners.
 - .16 Supply and install Bottom Layer Reinforcing Rebar:
 - .1 Rebar type: 10M rebar.
 - .2 Install lower rebar first parallel to pipe chairs (perpendicular with floor piping) with 12" on center spacing.
 - .3 Install upper rebar second parallel to cold floor pipes with 10 1/2" on center spacing. Upper rebar to sit in pipe chairs.
 - .4 Rebar to be tied, using high-visibility tie wires, at every intersection along the diagonal, starting at every third rebar intersection along the length of the rebar.
 - .5 Secure rebar to radius rebar at the radius ends using tie wires.
 - .6 Secure rebar to pipe chairs using tie wires at every three intersections, staggering ties at every chair.
 - .17 Supply and install Top Layer Reinforcing Wire Grid:
 - .1 To be installed on top of rink piping.
 - .2 6x6x6/6 (inches, inches, & gauge) welded wire mesh placed on top of rink piping supports (chairs) across whole area of rink slab.
 - .3 Any cut portions must be secured. 6x6 grid reinforced structure must be maintained.
 - .4 Top reinforcing must be laid and lapped to not exceed two (2) layers, and securely tied to pipe chair supports using tie wires.
 - .1 Wires must have loose ends cut and be turned away from and not on top of piping to avoid damage.
 - .2 Tie mesh to pipe chairs a minimum of every 12" along the pipe chairs and around the perimeter of each mesh sheet.
 - .3 Overlaps must be tied together with loop-type wires at a minimum of 12" spaces in two directions.
-

- .5 Install continuous wire mesh above the rink pipes with 6" overlaps. Tie overlaps as noted above.
 - .6 Trimmed corners to maintain two (2) layers overlap max.
 - .7 Use flat sheets only. Rolled will not be approved.
 - .8 Under no circumstances shall wire mesh be tied to the rebar.
- .18 Supply and install Perimeter Rebar Anchors.
- .1 Provide concrete anchors and stainless steel eyebolts. Secure to the perimeter concrete along the ends and radii.
 - .2 To be space at 18" on center at rink radius and ends.
 - .3 Minimum 600 lbs working load limit.
 - .4 Install pre-curved 10M rebar in eyelets at radius ends and straight rebar at straight ends.
- .19 Supply and install new Rink Slab Concrete:
- .1 Provide a 5" concrete slab, finished level.
 - .2 Maximum 1 3/4" concrete coverage over rink pipes.
 - .3 Floor slab tolerance:
 - .1 Cold slab tolerance must be measured using f-number system.
 - .2 Classification D, Extremely Flat
 - .3 Floor Flatness (FF) and Floor Levelness (FL) to be measured in accordance with ASTM E1155M
 - .4 Specified Overall Values (SOV)
 - .1 Flatness: FF 45
 - .2 Levelness: FL 35
 - .5 Minimum Local Values (MLV)
 - .1 Flatness: FF 30
 - .2 Levelness: FL 25
 - .6 Inspection and floor tolerance measurements shall be made within 72 hours of completing floor slab. The Contractor of this scope is responsible for all testing requirements to demonstrate to the Consultant that the floor flatness and levelness meets these specifications in reference to ASTM E1155M.
 - .1 Use a D-Meter or approved equivalent for all measurements on floor flatness and levelness. Provide results in a report to the Consultant.
 - .2 Note that ASTM E1155M, Part 8 Procedure, lays out the steps the Contractor must take for compliant measurements including grinding the floor area in 11.8" sections.
-

- .7 Specified floor tolerances that fall below the MLV shall be corrected by grinding. Any work of this nature must be approved by the Consultant prior to commencement.
 - .4 Material Properties:
 - .1 Strength: 4,641 psi at 28 days. Minimum average of strength test must exceed specified strength.
 - .1 Provide certification that mix proportions selected will produce concrete of specified quality and yield strength will comply with ACI 301-20.
 - .2 Air Content: Maximum of 2% non-entrained air.
 - .3 Maximum Water to Cementitious Material (W/CM): 0.45
 - .4 Fly Ash:
 - .1 Supplementary Cementing Materials (SCM): Maximum 15% total cementitious content.
 - .2 Type C or F.
 - .3 Loss of Ignition (LOI) not to exceed 1%
 - .4 Use fly ash from one source.
 - .5 Maximum Aggregate: 0.55" graded
 - .6 Water reducing and high range water reducing (superplasticizer) admixtures shall be included in concrete mix as required to maintain max W/CM ratio while ensuring required flowability.
 - .5 Include a Shrink-Reducing Admixture
 - .1 Must reduce capillary tension of pore water in cementitious mixtures.
 - .2 Provide moderate to significant reductions in the drying shrinkage of cementitious mixtures.
 - .3 Reduce stresses induced from one-dimensional surface drying in concrete slabs.
 - .4 Must be mixed at the factory. Mixing on-site will not be permitted.
 - .5 Standard of Acceptance: MasterLife SRA-035, or approved equivalent.
 - .6 Slump range before plasticizer: $2.8" \pm 0.79"$.
 - .7 Slump range at discharge: $5.1" \pm 1.2"$.
 - .8 Use approved set retarding admixture at the manufacturers required dosage when concrete is placed at ambient temperature above 86°F.
 - .9 Use approved accelerating admixture at the manufacturers required dosage when concrete is placed in ambient temperatures below 50°F.
-

- .10 Calcium chloride admixtures are not permitted for use.
- .20 Supply and install a water-tight expansion joint with pre-compressed expansion joint system and sealant cover along the rink perimeter.
 - .1 Expansion joint to extend along the rink perimeter, between the rink concrete slab and the perimeter slab.
 - .2 Joint specifications:
 - .1 Use a preformed elastomeric joint seal only.
 - .2 Material: neoprene (synthetic rubber).
 - .3 Total Movement: 0.800”.
 - .4 Minimum Install Width: 1.000”.
 - .5 Nominal Height: 2.000”.
 - .6 Tensile Strength: 2,000 psi.
 - .7 Hardness, Shore A: 55 ± 5.
 - .8 Materials must comply with ATSM D3542 and AASHTO M297.
 - .9 Standard of Acceptance: WABO WA-175, or approved equivalent.
- .21 Pouring
 - .1 Pour to be carried out using laser levelling devices.
 - .2 The concrete pour is to be completed in one continuous pour, beginning from the South end of the rink slab and concluding on the North end.
 - .3 Continuous supervision of the pour by the Contractor is required for the total duration of the pour.
 - .1 Contractor to adjust concrete hoses and clamps as required during the pour to avoid damage.
 - .4 Concrete pumping equipment must be kept out of direct contact with the floor structure.
 - .1 To avoid the concrete hose clamps from dragging and damaging the floor structure (mesh, pipes, etc.) the Contractor is to place wooden support blocks beneath each clamp in contact with the structure.
 - .5 No concrete vibrators are to be used.
 - .6 Finishing to be performed to provide specified flatness and levelness numbers. Advanced mechanical screeding and ride-on power trowels required. Finish per Class 9 ACI 302.1.
 - .1 Ensure the screeding machine or trowels is placed on plywood while finishing the floor.
- .22 The Contractor must submit a Pour Plan in advanced of the concrete pour. A minimum of two (2) months if required for

submitting the pour plan to allow for sufficient time for comments and to coordinate site activity with the Owner and Consultant. This plan must include information such as:

- .1 Details of which companies and who will be on-site during the day of the pour. This can include Owner and Consultant representatives, Contractor representatives, concrete subcontractors, mechanical subcontractors, testing subcontractors, general labor, etc.
 - .2 The approval authority for the batches/trucks as they arrive on-site.
 - .3 An outlined of a schedule of events throughout the day. This should include start time, when trucks will arrive, the frequency of trucks, and the expected completion time.
 - .4 Specific equipment data sheets that will be used.
 - .5 Calibration certificates for any leveling devices.
 - .6 Testing plan, including a reporting procedure.
 - .7 Method of screeding.
 - .8 Concrete plant information.
 - .9 Plan for alternate mix or a back-up plant in the event the concrete fails testing.
 - .10 Site details outlining the method of our, truck, and pump locations including the site entrance.
 - .11 A space ventilation plan to monitor and reduce CO levels.
 - .12 A contingency plan in the event of a piping failure.
 - .13 Curing and protection plan post-pour.
- .23 Testing:
- .1 Upon completion of the warm floor piping system, the header and floor tubing shall be tested at 100 PSIG with air over a continuous 24-hour period, 48 hours prior to the sand fill. Pressure shall be reduced to and held at 50 PSIG for the duration of the sand fill and compacting. Report all findings to the Consultant in writing upon completion of the sand fill.
 - .2 Upon completion of the cold floor piping system, the header and floor tubing shall be tested at 100 PSIG with air over a continuous 24-hour period, 48 hours prior to the concrete pour. Following approval of the testing by the Consultant, the pressure of the cold floor piping systems shall be maintained at 50 PSIG with air until the concrete floor is poured and one 24-hour period has passed upon completion of the floor to verify that the floor piping is not damaged.
-

- .3 A failed test includes the following: loss of pressure, damage to the pipes, failures of seals (including welds at joints).
 - .4 The Consultant shall be present to witness the testing and concrete pour. The Contractor shall notify the Consultant no less than one (1) month in advance of the testing date.
 - .5 If, during the inspection, any defects are found in the installed material, equipment, or workmanship the pressure testing procedure must be repeated.
 - .1 This includes the both the 100 PSIG and 50 PSIG cold floor piping tests.
 - .6 Upon completion of each layer, for the durations noted above, with a specified level tolerance, the Contractor is to provide a report detailing the findings of a laser leveling test to the Consultant. The test results must be acknowledged by the Consultant prior to proceeding with the installation of the next layer.
 - .1 If the required tolerance is not met this must be rectified immediately by the Contractor. No allowance for extra time or compensation will be approved.
 - .2 The report must list the layers, as installed, and provide documentation and testing results for each layer.
 - .7 Contractor to provide concrete test results no later than 24 hours after the test.
 - .8 All tests must be completed no later than 72 hours after the pour.
 - .24 Concrete Pour Site Logistics:
 - .1 The Contractor is solely responsible for all site logistics on the day of the pour. This includes coordination
 - .2 As the rink floor is required to be done in one continuous pour, the Contractor must consider the timing of the pour itself including:
 - .1 Testing capacity for the concrete, especially in relation to the testing of concrete in the trucks prior to when they can be used for the pour.
 - .2 Number of trucks when they arrive and how many are on-site at a given instance.
 - .3 How often trucks show up from the plant.
 - .4 The logistics around the job site, including where concrete will be poured and where testing is going to take place.
-

.5 Concrete batch expiry time.

.25 Curing and Protection:

- .1 Refrigerated slab must be cured for a minimum of 28 days.
- .2 Protect and guard the finished concrete surface at all times from abrasion, concentrated construction point loads, and impact damage for 28 days after the concrete pour.
 - .1 Using blankets specifically designed and manufactured to protect the concrete during curing.
- .3 No construction equipment including lifts, fork trucks, and pallet jacks should be placed on the surface for the first 28 days after the pour.
- .4 Prevent construction traffic over edges to protect exposed concrete from chipping for 28 days after the concrete pour.
- .5 Any defects, abrasions, or construction waste on the floor must be rectified.
- .6 Cover the ice surface using plyboard and tarps to prevent dust or construction debris from settling on the ice surface. Remove prior to ice making.
- .7 Prior to ice making, the floor must be swept then washed with a trisodium phosphate style cleaner and rinsed with fresh water by the Contractor. Cleaners with soap or lanolin are not acceptable.

.26 Provide an Access Box.

- .1 The purpose of the box is to access the purge valves and warm floor stubby headers.
 - .2 Supply and install:
 - .1 Two (2) vent valves for the underfloor warm glycol.
 - .2 Four (4) vent valves for the cold glycol.
 - .3 Two (2) drain valves for the underfloor warm glycol.
 - .3 Location is noted in the drawings package.
 - .4 To be a steel box with removable lid.
 - .5 Formed area to be 144" long x 72" wide.
 - .6 Access box dimensions are to be 72" long x 30" wide x 24" deep.
 - .7 Do not pour until poly pipe is connected to headers and access box is located in coordination with other scopes of work.
 - .8 Contractor to supply and install one (1) steel access box lid suitable for patrons to stand on.
 - .1 Lid must be flush with the building floor and secure to prevent tampering.
-

- .2 After installation is completed, the lid is painted by others.
 - .27 The cold and warm floor system shall be charged with new 40% Ethylene Glycol with all required additives and inhibitors.
 - .1 Submit all data sheets for approval and test results after charging for the mixture as installed.
 - .2 Complete all testing prior to start-up.
 - .28 Reinforcing rods, rebar, and mesh edges must not lie closely above or below pipes to avoid pipe puncture.
 - .29 Under no circumstances must any materials protrude above the finished concrete floor.
 - .30 All pipe joints to be fusion welded only.
 - .31 Piping for the system must not be tied to any rebar unless otherwise noted.
 - .32 Any loose rebar or other supporting structure will not be approved during the floor inspection and must be rectified prior to the concrete pour.
 - .33 Contractor to connect to drainage as required.
 - .34 A licensed journeyman mechanic must be present during the concrete pour.
 - .35 Contractor is responsible for all required coordination of details and construction logistics with other Contractors.
 - .36 In-floor temperature sensors are to be supplied for the floor by the automation contractor, the contractor of this scope of work is to place and install these.
 - .1 Refer to the Drawings Package for positioning details.
 - .2 Cold floor sensors affixed to underside of conduit body cover plate.
 - .3 Use 1" Type C aluminum conduit fitting with neoprene gasket and steel flat top cover plate. Wiring from sensors to plant room using 3/4" PVC electrical conduit.
 - .4 Cut sections in top layer of concrete reinforcing wire mesh to position conduit box and install one complete 6x6 mesh centered around the box for structural reinforcement.
-

4.5 Ice Rink Floor
Concrete Quality
Control

- .1 The contractor shall adhere to the quality control requirements outlined in this section. A representative from the contractor shall confirm all on-site testing.
 - .2 A representative of the concrete inspection company must be present at the time of pour. The concrete engineer is able to reject concrete batches that do not meet specifications.
 - .3 Cold floor concrete shall be placed as one monolithic slab, completed as one continuous operation to be completed within 8 hours of commencement.
 - .4 The use of pencil vibrators, or any such equipment, which may damage the cold floor pipes is not permitted.
 - .5 The concrete supplier shall be no more than a 120-minute transport distance from the job-site. If the vendor is outside of this distance, the concrete supplier is to carry the cost of set-retarders under the direction of a concrete engineer. This may only be considered acceptable if the supplier demonstrates that all mechanical requirements are still met.
 - .6 Provide batch tickets (Certificate of Compliance sheets) for every truck. Tickets must include:
 - .1 Plant name;
 - .2 Truck Number;
 - .3 Date and Batch time;
 - .4 Slump;
 - .5 Temperature;
 - .6 Cylinders cast;
 - .7 Time truck poured;
 - .7 Water is not allowed on-site without approval by the concrete engineer.
 - .8 The contractor must provide a back-up pump onsite such that in the event of failure of the primary pump, work may continue uninterrupted.
 - .9 Concrete installers and finishers to be alert for pipe leaks. If any leaks are found, repair and retest piping system immediately.
 - .10 All debris must be removed from pour area before pour begins and no debris shall be deposited in the concrete during pour.
 - .11 On-site testing shall be performed as follows and each test must pass.
-

Concrete Quality Assurance Tests			
Test	Frequency	No. of Repetitions	Note(s)
Slump	Per Truckload	3 - Successful	All three tests must be successful.
Air Content	Per Truckload	3 - Successful	At the point of deposition
Compression	Per 50 cuyd.	Set of four cylinders per sampling for 7, 14, 21, and 28-day interval compression tests	Dependent on amount of concrete used during the floor pour.

.12 The Slump testing shall be performed on each truckload of concrete received. Before pouring, the Contractor Representative shall meet the delivery driver (supplier representative). A sample of the concrete shall be taken and tested. The slump testing shall be repeated until the test yields a successful result.

.1 If the slump tests yield results which are not within the acceptable range, the Contractor must reject the batch. At this time the Contractor must contact the concrete engineer at the ready-mix facility to see if the slump can be improved without compromising the batch integrity.

.13 Air content testing shall be performed at the time of concrete delivery, at the point of deposition (i.e. through all concrete pumping systems). The air content test shall be performed a minimum of three times; the results shall be recorded and be signed by the on-site foreman.

.14 Compression test samples shall be taken at every 50 yd³ of concrete delivered. The compression tests shall be completed by the contractor, or by a third party testing lab at the cost of the contractor, at 7-day, 14-day, 21-day, and 28-day intervals.

.15 Pour one truck at a time unless testing capacity and site logistics permit additional trucks. The Contractor is to ensure there are three (3) testers per pouring truck.

4.6 Ice Rink Floor Concrete Reporting and Test Results

- .1 Electronic copy of test reports and log must be transmitted to the Consultant as soon as the tests are completed and results are available.
- .2 The Consultant shall document and evaluate all test results as they become available. The overall project test results shall meet or exceed specification and the results shall be precise with a pre-set acceptable standard deviation.
- .3 For each test category there shall be an acceptable maximum standard deviation comprised of all test results taken over the project duration, and there shall be a 'Global' testing minimum or maximum (whichever is the limiting factor). These values are summarized for all regularly measured quantities in the table below:

Concrete Quality Assurance Tests		
Test Category	Max. Standard Deviation	Global Testing
28-Day Compressive Strength	580 psi	4,641 psi [Minimum]
On-Site Air Content	1%	2% Non-Entrained [Maximum]
On-Site Concrete Slump	1.18"	5.14" [Maximum]

- .4 If during the project duration the data exceeds the allowable standard deviation in any of the testing categories, the Consultant shall notify, in writing, the contractor. The contractor shall investigate the source of the deficiency, and implement corrective action such that the concrete meets specification.
 - .1 If the corrective action fails to increase the concrete consistency, the Consultant shall notify the client, contractor, and concrete supplier, in writing informing

them of the deficiency. At this time the Consultant reserves the right to suspend work on behalf of the client until the contractor can return the concrete to specification.

.5 If a series of concrete compressive tests fail to meet global minimums after curing, the Consultant reserves the right to enforce any of the following remedial actions

.1 The Consultant may request, at the option of the client, that concrete samples be retrieved from the site for third party testing. If the concrete samples pass the mandated test, the cost of additional testing shall be carried by the client. If the concrete fails the testing, the cost shall be carried by the contractor.

.2 The Consultant may, at the option of the client, instruct the full or partial demolition of the arena floor. The demolished section shall be carried by the contractor.

4.7 Ice Rink Floor Specific Requirements

.1 The Contractor is responsible for:

.1 Completion the Work in conjunction with the Owner and the Dasher Board installer.

.2 Removal and disposal of construction waste.

.3 All permits where applicable.

.4 Supply and install all required building materials.

.5 All required demolition and material removals to provide a new floor installation, including removing the existing concrete, piping, supports, insulation, boards and glass, header pipes, and other equipment as required.

.1 Contractor is responsible for pumping out and disposing of the existing cold floor refrigerant. Existing facility equipment is not to be used for the pump-out. Provide proof of disposal once completed to the Consultant.

.2 Work to be coordinated with the Owner, as well as the other contractors working in parallel at the facility.

.3 The Consultant shall be present to witness the pressure testing of the warm and cold floor piping systems, and shall be notified by the Contractor at least one-month in advance of the testing date. The Consultant shall also be present to review the completed floor assembly. Any modifications to the assembly deemed necessary at the Consultant's sole discretion must be rectified prior to the concrete pour.

.1 Any deficiencies in the installation, prior to pour and testing, noted by the Contractor shall be reported to the Owner and Consultant prior to the inspection. After these items have been

rectified, the Consultant will perform an inspection of the ice rink floor system work prior to the concrete pour and testing as part of an independent performance commissioning.

- .2 Any subsequent inspections required as a result of incomplete or deficient work shall be at the cost of the Contractor (\$950 per Consultant inspector).
 - .4 Contractor to ensure proper site conditions prior to pouring and during the pour, this includes but is not limited to:
 - .1 Ensuring all workers, of the contractor or subcontractor, are using CO chest sensors or actively monitoring CO throughout the pour zone. Should CO levels rise above the safe limit, the Contractor is to inform the Owner and Consultant while taking immediate corrective action.
 - .2 Contractor is solely responsible for actively maintaining the zone temperature during the pour within a range of 59°F to 68°F to ensure proper pouring and curing.
 - .5 Contractor to connect to the existing sub-floor drain. All required pipes, fittings, and connectors are to be included.
 - .6 Dasher board anchors shall be installed prior to concrete pour by others, to be coordinated by the Contractor.
 - .1 Dasher board installer must provide all mount and goal post hole locations.
 - .7 The Contractor is responsible for all preparations required for the installation of the rink floor and cold slab assembly as specified, including but not limited to:
 - .1 All geotechnical and concrete engineering work. Reports to be provided to the consultant withing 5 working days of inspections.
 - .2 Sub-base inspection.
 - .3 Sand sub-floor compaction inspection.
 - .4 Rink floor concrete mix design, including required admixtures.
 - .5 Overlay concrete for curved section of floor at header trench.
 - .6 All structural work and inspections, including:
 - .1 Header trench wall, interface with new slab, and header trench cover supports.
 - .7 All excavation required to install the cold slab system. The top of the cold slab is to be flush with the existing perimeter slab and the total cold slab system cross-section is 16". Cap all drainage holes in the header trench during construction. Remove caps upon completion.
-

- .8 Piping installed in public spaces shall be located inside a metallic mesh cage to prevent damage and unauthorized access.

PART 5 – ICE RINK DASHER
BOARDS

5.1 Ice Rink Dasher Boards
Description

- .1 Remove and dispose of (1) panelized dasher board system for Rink 1.
- .2 Supply and install one (1) panelized dasher board system for Rink 1. This system must consist of factory pre-fabricated sections having aluminum framing and HDPE facing. 5” deep profile is required throughout the entire system. All gates, hardware, shielding, shielding supports, glass, boxes and anchor bolts necessary to provide a complete and functional dasher board system are required.
- .3 Remove, store, and reinstall one (1) panelized dasher board system for Rink 2.
- .4 The Work shall consist of the provision of all labor, materials, tools, equipment, testing, commissioning, transportation, shipping, handling, administration, supervision, management, insurance, temporary protection, cleaning, cutting and patching, warranties, services, and items, even though these may not be specifically mentioned in these documents which are required for the complete, fully functional and commissioned dasher board systems.
- .5 Manage and coordinate the work in a timely manner in consideration of the Project schedules. Coordinate with the associated work of other trades so as to not impede or delay the work of associated trades.

5.2 Dasher Boards Scope
of Work

- .1 Remove, store, and reinstall one (1) panelized dasher board system for Rink 2 as indicated in the drawings package.
 - .1 The existing netting is to be detached and rolled up as per Section 5.14
- .2 Remove and dispose of one (1) panelized dasher board system for Rink 1.
- .3 Supply and install one (1) panelized dasher board system for Rink 1 as indicated in the drawings package.
 - .1 The existing netting is to be detached and rolled up as per Section 5.14

5.3 Product Description

- .4 A panelized arena dasher board system shall consist of prefabricated, modular panel sections having aluminum framing and HDPE facing. A 5” deep profile is required throughout the entire system. All gates, hardware, shielding supports, and anchor bolts
-

required to provide a complete and functional dasher board system are required.

- .1 System must be suitable for an 85' x 200' ice rink with 28' corner radii.
 - .1 Arena Survey (Section 5.3) to confirm final dimensions.
 - .2 Standard of Acceptance: Athletica Sport Systems Pro Series Dasher Board System, or approved equivalent.

5.4 Dasher Boards Survey

- .1 Perform a survey of the dasher boards for each of the two (2) rink zones prior to removal.
 - .1 Work to be completed by a professional survey engineer licensed in the State of Illinois.
 - .2 The intent is to confirm exact dimensions of the existing Rink 1 dasher boards for door locations and backer types.
 - .3 The intent is to confirm exact dimensions of the existing Rink 2 dasher boards for reinstallation.

5.5 Materials

- .1 All aluminum extrusions will be ATSM B221-14 and 6005-T5 or T6 alloy and temper. Aluminum to be clear anodized.
 - .1 Contractor to provide certification for anodization, demonstrating conformance to Aluminum Association designation AA M12C22A31.
 - .2 Thickness: 0.0002 in. minimum coating thickness.
- .2 Impact panels are to be polycarbonate.
- .3 All other plastic to be High Density Polyethylene (HDPE), high impact.

5.6 Arena Panels

- .1 Arena panels shall be prefabricated, 42" in height, above the refrigerated floor surface, and not more than 8' in length per section with two (2) vertical posts. Each panel is to be assembled using high strength fasteners.
 - .1 Connect frames with heavy duty, 5/8" zinc-plated steel bolts.
- .2 Framing to be aluminum with clear anodized finish.
 - .1 Frames must allow for fastening of the HDPE facing and anchoring at base. Ensure flush mating of the HDPE facing at arena panel joints.
- .3 Supply and install impact absorbing cap rail system around the perimeter of the ice hockey rink, on the ice-side of the shielding, in lieu of standard HDPE. Spectator side of glazing and return and backwalls at the boxes to remain HDPE. Panels shall be clad with 3/4" colored cap rail. Edges of the cap rail must be smooth and radiused.

- .1 Cap Rail Material on ice side: Extruded thermoplastic with built-in voids.
 - .2 HDPE is to be used inside the boxes and on the spectator sides.
 - .3 The impact absorbing system must meet or exceed the following performance standards:
 - .1 Durometer reading must be rated 70A or less.
 - .2 ASTM D638 Standard Test Method for Tensile Properties of Plastics:
 - .1 Average Peak Load: 60 lbf
 - .2 Average Peak Stress: 800 psi
 - .3 Average Strain at Break: 500%
 - .3 ASTM D695 Standard Test Method for Compressive Properties of Rigid Plastics:
 - .1 Average Peak Load: 115 lbf
 - .2 Average Peak Stress: 70 psi
 - .3 Modulus: 850 psi
 - .4 ASTM D790 Standard Test Method for Flexural Properties:
 - .1 Peak Load: 12 lbf
 - .2 Peak Stress: 165 psi
 - .3 Modulus: 6800 psi
 - .4 Standard of Acceptance: Athletica Sports Systems SoftCap[®], or approved equivalent.
 - .1 All bidders are advised to respect any installation and design configuration patents which apply to providing a dasher board cap rail made of extruded thermoplastic elastomer (polyurethane) with built-in voids. If a conflict exists the bidder is required to obtain written permission to install this product, or use an alternate system that is deemed equivalent by the Consultant.
 - .1 The bidder is required to provide all detailed design and equipment selections for an alternative system. This alternative system must be submitted to the Consultant for approval.
 - .4 7 7/8" HDPE kick-plates shall be mounted to the bottom of the panels. Top of the kickplate must have a radiused edge. Each kickplate must be 1/2" thick and inlaid to the panel face.
 - .5 Accurately fit together all joints, corners, and intersections. The Contractor must match components to products to ensure the system is level and flush.
 - .6 Supply and install half height backer plastic, 3/8" white HDPE backers on the rink perimeter as shown in the drawings package
-

with Gap Closure. Backer panels must be securely attached to the arena board framing.

.1 On the rink-side panels for the player's boxes, the inside of that panel must be half-height backers to allow for placing bottles.

5.7 Player's, Penalty, and
Official's
Boxes/Benches

- .1 Boxes and framing must be constructed similarly to the arena panels. Interior finishes of boxes must be 3/8" thick HDPE to the height of mid-stringer on the front side to provide a shelf. Include full-height HDPE on all other sides.
- .2 Boxes shall consist of two player's boxes, two penalty boxes, and one official's box.
- .3 Player's boxes shall be 27' in length and 55" deep and located as indicated in the associated drawings package. Two player gates shall be installed in each of the player's boxes.
- .4 Penalty boxes shall be 82" in length and 55" deep and located as indicated on the drawings package, with one player gate onto the ice per box.
- .5 Official's box shall be 51" long and 55" deep and located as indicated in the associated drawings package.
- .6 Official's box shall include a full-width table with pencil holder, electrical outlet, and chairs.
 - .1 Re-use existing electrical connections.
- .7 Player's and penalty boxes shall include benches mounted to the concrete floor. Benches must be a nominal 9 1/2" deep and mounted on pedestals 22" above the floor.
- .8 Provide a coach's walkway, in each of the player's boxes.
 - .1 Height: 8"
 - .2 Depth: 3/8"
 - .3 Exposed sides covered with 3/8" white HDPE.
- .9 All box floors and coach's walkway are to be covered with 1/2" rubber matting and laid loose.
 - .1 Use only non-absorbent rubber matting.
 - .2 Hardness: ATSM D2240 75 +/- 5
 - .3 Material: Vulcanized rubber.
 - .4 Standard of Acceptance: NWR Sport SportFloor Stamina, or approved equivalent.
 - .5 Cut 1/2" thick rubber flooring and matting to neatly fit in all boxes.

5.8 Spectator Shielding
Supports

- .1 5/8" thick clear tempered glass to be installed on the side, corners, and ends of the rink at a height of 72" above the dasher boards and cap rail.

- .2 Only tempered safety glass, heat tempered and fully toughened is to be used.
 - .1 Glass must be clear and colorless.
 - .2 Roll-wave distortion must not exceed 0.005" from peak to valley.
 - .3 Glass must meet:
 - .1 ANSI Z97.1-2009 Class A
 - .2 CPSC 16 CFR 1201 Category II
 - .3 ASTM C1048
 - .4 Each piece of glass must bear an approval stamp from a certified testing facility. This is to ensure that the glass meets the requirements of Section 1.6 References. Stamp must be clearly visible and legible.
- .3 Spectator shielding shall be installed around the player's boxes as indicated in the drawings package.
- .4 Provide one (1) speaker hole, it shall be 3 1/4" and incorporated in the official's box, for communication between the official and the referees on ice, and between the official and the players in the penalty boxes.

5.9 Spectator Shielding Supports

- .1 Aluminum vertical supports shall keep the spectator shielding in place. Aluminum support must run continuously to within 12" of the top of the glazing. Use only plastic U-shaped gaskets to protect the glass edges.
- .2 At the gates, the supports are secured with a screw-applied aluminum face plate.
- .3 The design shall allow for easy replacement of shielding from the ice-side without requiring additional support or securing adjacent shields.

5.10 Gates

- .1 Supply and install gates in locations as indicted on the associated drawings package, including replaceable HDPE thresholds.
 - .1 Three (3) Single Access Gates, 36"
 - .2 Seven (7) Player Gates, 30"
 - .3 One (1) Machine Gate, 120" (2x60").
- .2 Gates must be single latch type. All gate hinges and latch to be heavy duty stainless steel.
- .3 Provide gate thresholds 1" white HDPE on 1 1/2" aluminum extrusion.
- .4 Provide a flush mounted push-button latch release in the cap rail on the ice entrance gates where shields would otherwise prevent latch operation. The push-button shall be designed to be simple to operate from the ice side of the shielding (suitable for opening gates with hockey glove on hand), yet prevent accidental opening.

- .1 On rink side of single access gates.
- .5 One (1) 120" machine access double-gate beside the Ice Resurfacers room.
 - .1 Machine gate must be double gates.
 - .2 Include all gate locks and door hardware required. Gates must swing away from the rink to allow an Ice Resurfacers to pass.
 - .3 Provide HDPE machine gate thresholds to be flush with the perimeter slab.
 - .4 Doors must not be able to open into the ice surface.
- .6 Materials:
 - .1 All gate hardware to be heavy duty stainless steel.
 - .2 All nuts, washers and bolts to be zinc plated.

5.11 Anchors

- .1 Board anchors shall be mounted in the perimeter concrete.
 - .1 Coordination and placement of the anchors is the responsibility of the Contractor within this Division.
 - .2 Anchors are to be minimum 5/8" threaded rods installed with epoxy anchors drilled into perimeter concrete.
 - .3 Minimum drill depth: 4"
 - .4 Anchors must be galvanized steel or zinc plated.
- .2 Goal-post anchors are to be drilled into the existing rink floor concrete. Work with the Owner's staff to sweat the rink to locate suitable positions.
- .3 Use zinc plates bolts or threaded rods and nuts for tightly fastening the anchors to the perimeter concrete.

5.12 Colour

- .1 Contractor to coordinate shade and type of colours with the Owner and the Consultant. Specific colour ID to be confirmed and approved prior to ordering. Guidelines are below:
 - .1 All panels, including gates, to be white.
 - .2 All kick-plates to be yellow on the inside of the rink.
 - .3 All netting is to be white.
 - .4 All cap rail to be blue.

5.13 Curved Acrylic Termination Assembly

- .1 At players boxes, where perimeter shielding terminates its continuous run, in lieu of an aluminum post that supports both the shielding that runs along the sides of the box and the perimeter shielding at a right angle, install a curved acrylic panel mounted on impact absorbing sleeves. Each of the four locations for these panels must be identical, allowing for a spare to replace any of the panels as required.
 - .1 Product to be NHL approved.
 - .2 Durometer reading must be rated 70A or less.
-

- .3 Provide a list of ten (10) arenas currently using this product for verification with contact information. The Owner and the Consultant reserve the right to visit the sites provided and view the installation.
- .4 Include one spare curved acrylic termination.

5.14 Protective Netting

- .1 Protective Netting
 - .1 Netting is to be installed by the Contractor and attached to the new dasher board system.
 - .2 Supply and install white nylon Protective Netting, where indicated on drawings.
 - .3 Netting must be fastened to the shielding supports to prevent pucks from leaving the ice rink zone. Eyebolts are an acceptable fastening method.
 - .4 Install the netting system so it matches the curvature of the dasher board system.
 - .5 All hardware required for a complete protective netting system is to be included. This includes, but is not limited to, beam clamps and cables.
- .2 Detach the existing netting and anchors from the dasher boards which are being stored and roll it up to prevent it from interfering with construction. Secure the rolled-up netting to the ceiling structure. The netting is to be reinstalled following the reinstallation of the stored dasher boards.
- .3 Detach the existing netting and anchors from the dasher boards which are being replaced and roll it up to prevent it from interfering with construction. Secure the rolled-up netting to the ceiling structure. The netting is to be reinstalled following the reinstallation of the new dasher boards.

5.15 Specific Requirements

- .1 The proponent is responsible for:
 - .1 Completion of the Work in conjunction with the Owner.
 - .2 Removal and disposal of construction waste.
 - .3 All permits where applicable.
 - .4 Supply and install all required building materials.
 - .2 Work to be coordinated with the Owner, as well as the other contractors working in parallel at the facility.
 - .3 Contractor is responsible for cleaning and remove debris from the site related to the work outlined in this Division.
 - .4 All permits and local approvals as required are the responsibility of the Contractor.
-

- .5 Remove six (6) 6" lengths of frame floor plate and matching 2" high by 6" sections of facing for rink drainage.
 - .1 Install removable kickplates at front and back.
 - .6 Extra hardware, cap rails, and two spare pieces of each size of tempered glass to be provided. These are required to be left with the Owner following commissioning of the dasher boards system. This shall consist of:
 - .1 Fifty (50) additional painted screws of each colour required for fastening of HDPE facings.
 - .2 Two (2) extra pieces of facing, cap rail (straight and curved) and kickplate.
 - .3 Two (2) extra pieces of each standard size piece of tempered glass for the ends and sides.
 - .4 Two (2) extra pieces of 72" x 96" nominal 1/2" acrylic to handle all special sizes of glass.
 - .7 The existing electrical and equipment in the official's boxes are to be salvaged. The contractor is to remove and safely store this to be reinstalled following the installation of the dasher board systems. Cap all electrical wiring and parts that cast in place and preserve throughout construction.
-

PART 6 – WATER PIPING

6.1 Water Piping General Comments

- .1 All work of this Division shall be coordinated and provided by the Mechanical Contractor.
- .2 All materials shall be first class and new.
- .3 The Mechanical Contractor shall work with the facility, and the Consultant to provide completed hydronic piping in a timely manner.
- .4 The work of this Division shall be as required by the Specifications and Schematic.
- .5 If the Contractor believes there are conflicts or missing information in the project documents, the Contractor shall promptly request clarification and instruction from the Consultant.

6.2 Water Piping Definitions

- .1 Water Piping: Piping which contains water (or a glycol mixture) for the purpose of distribution to loads.
- .2 Mechanical Contractor (or Contractor): The Contractor responsible for supply and installation of all water piping components and requirements as specified.

6.3 Water Piping Description

- .1 The supply and installation of piping, labeling, identification and insulation as outlined.
 - .2 The work shall consist of the provision of all labour, materials, tools, equipment, testing, commissioning, training services, transportation, shipping, handling, administration, supervision, management, insurance, temporary protection, cleaning, cutting and patching, warranties, services, and items, even though these may not be specifically mentioned in this documents which are required for the complete, fully functional and commissioned water piping system.
 - .3 Provide a complete, neat and workmanlike installation. Use only manufacturers and employees who are skilled, experienced, trained, and familiar with the specific equipment, software, standards and configurations to be provided for this Project.
 - .4 Manage and coordinate the work in a timely manner in consideration of the Project schedules. Coordinate with the associated work of other trades so as to not impede or delay the work of associated trades.
-

6.4 Water Piping Quality Assurance

- .1 General
 - .1 The Contractor shall be a recognized national supplier, installer and service provider for water piping.
 - .2 As part of Risk Management and evidence and assurance of the contractor's ability to support the Owner's system with service and parts, the Contractor must have been in the business for at least the last ten (10) years and have successfully completed a total of ten (10) piping systems in the preceding five (5) years.
 - .2 Workplace Safety and Hazardous Materials
 - .1 Provide a safety program in compliance with the Contract Documents.
 - .2 The Contractor shall have a corporately certified comprehensive Safety Certification Manual and a designated Safety Supervisor for the Project.
 - .3 The Contractor and its employees and subtrades comply with federal, state and local safety regulations.
 - .4 The Contractor shall ensure that all subcontractors and employees have written safety programs in place that covers their scope of work, and that their employees receive the training required by the Health and Safety Commission in the jurisdiction for at least each topic listed in the Safety Certification Manual.
 - .5 Hazards created by the Contractor or its subcontractors shall be eliminated before any further work proceeds.
 - .6 Hazards observed but not created by the Contractor or its subcontractors shall be reported to either the Consultant or the Owner within the same day. The Contractor shall be required to avoid the hazard area until the hazard has been eliminated.
 - .7 The Contractor shall sign and date a safety certification form prior to any work being performed, stating that the Contractors' company is in full compliance with the Project safety requirements.
 - .8 The Contractor's safety program shall include written policy and arrangements for the handling, storage and management of all hazardous materials to be used in the work in compliance with the requirements of the Authorities Having Jurisdiction at the Project site.
 - .9 The Contractor's employees and subcontractor's staff shall have received training as applicable in the use of hazardous materials and shall govern their actions accordingly.
-

.3 Quality Management Program

- .1 Designate a competent and experienced employee to provide Project Management. The designated Project Manager shall be empowered to make technical, scheduling and related decisions on behalf of the Contractor. At minimum, the Project Manager shall:
 - .1 Manage the scheduling of the work to ensure that adequate materials, labour and other resources are available as needed.
 - .2 Manage the financial aspects of the Contract.
 - .3 Coordinate as necessary with other trades.
 - .4 Be responsible for the work and actions of the workforce on site.

6.5 Water Piping Codes and Standards

- .1 Contractor to comply with all codes and standards applicable to this type of work, including;
 - .1 ASME B31.9 Building Service Piping
 - .2 ASME Boiler and Pressure Vessel Code
 - .3 Local, State and National Building Codes
 - .4 ASHRAE Standards
 - .5 OSHA Regulations
- .2 In the case of conflicts or discrepancies, the more stringent regulation shall apply.
- .3 All work shall meet the approval of the Authorities Having Jurisdiction at the project site.

6.6 Water Piping Record Documentation

- .1 Provide two (2) paper copies and one (1) electronic copy of as-built water piping schematics and layouts for all installed piping covered under this contract.
 - .2 Manual shall be bound in 3 ring binders and contain, as a minimum, the following:
 - .1 System operation and maintenance instructions, troubleshooting guidelines and operating log.
 - .2 Safety bulletins and material safety data sheets.
 - .3 Equipment operation and maintenance instructions.
 - .4 Signed Dept. of Labour (or equivalent) Pressure Tests Data Reports
 - .5 Shop drawings of all supplied equipment
 - .3 As-built drawings shall contain, typical piping layout, material details, piping connection details, and any additional pertinent details regarding the piping.
-

6.7 Water Piping
Warranty

- .1 Standard Material and Labour Warranty:
 - .1 The Contractor shall provide a one-year labour and material warranty from the date of substantial completion on the water piping system including all valves and fittings.
 - .2 If within twelve (12) months from the date of acceptance of product, upon written notice from the owner, any portion of the Water Piping system is found to be defective in operation, workmanship or materials, it shall be replaced, repaired or adjusted at the option of the Contractor and at the cost of the Contractor.

6.8 Water Piping Scope of
Work

- .1 Piping shall conform to ASME B31.9 Building Service Piping.
- .2 Piping shall be as follows
 - .1 All Glycol and Water Piping
 - .1 Up to 1 1/2" IPS
 - .1 Schedule 40 ERW OR
 - .2 Schedule 40 Seamless Black Steel Pipe With 150 LB Threaded, OR
 - .3 Schedule 40 3M Socket Weld
 - .2 2" IPS and up
 - .1 Schedule 40 ERW Black Steel Pipe with Standard Butt Weld Fittings,
 - .3 Pipe fittings shall be as follows
 - .1 Steel Piping
 - .1 Flanges ANSI & RF
 - .1 ASTM A105
 - .2 Pressure Rating to Match Design Working Pressure
 - .2 Up to 1 1/2" IPS
 - .1 Threaded – Forged Steel, ASTM A105, 3000 LBS
 - .2 Socket Weld – Forged Steel, ASTM A105, 3000 LBS
 - .3 Butt Weld – Carbon Steel, ASTM SA-234-WPB E.H.
 - .3 2" and Up
 - .1 Socket Weld – Forged Steel, ASTM A105, 3000 LBS
 - .2 Butt Weld – Carbon Steel, ASTM SA-234-WPB STD
 - .2 Copper Piping
 - .1 Up to 4"
 - .1 Join using lead free solder suitable for domestic water system in conformance with ASTM B52 Gr 50A.
 - .2 ATSM B88.
 - .3 Any connections to dissimilar metals to include dielectric union.

.4 Piping shall be identified as per Owner’s Current Labeling Standards. In the event that no standard is currently in place, labeling shall be as follows.

- .1 Labeling body shall be Black on Safety Yellow
- .2 Labeling shall indicate flow of water
- .3 Label Size, text height and placement should conform to ASME A13.1

- .1 Labels shall be adjacent to all valves and flanges
- .2 Adjacent to all changes of direction
- .3 On both sides of a wall or floor penetration
- .4 At regular intervals on straight runs (maximum 50 feet spacing)

.4 Label Size, and Letter Size

Outside Pipe Diameter, including insulation (in.)	Minimum Label Length (in.)	Minimum Letter Height (in.)
< 1.25	8	0.5
1.5 – 2	8	0.75
2.5 – 6	12	1.25
8 – 10	24	2.5
> 10	32	3.5

.5 All insulated field fabricated steel piping shall be painted with a rust resistant primer prior to painting and insulation.

- .1 Standard of Acceptance: Polyguard RG-2400 Primer, or approved equivalent.

.6 To further protect the piping system, the piping shall be painted.

.1 Colors shall match existing color scheme currently utilized at the facility. If no color scheme is present, the following shall be used

- .1 Light Blue Cold Glycol
- .2 Dark Blue Warm Glycol
- .3 Green Domestic Hot and Cold Water

.7 Piping shall be supported as follows

Nominal Diameter Pipe NPS (in.)	Recommended Spacing Between Hangers (ft.)	Minimum Rod Size (in.)
1/2	7	3/8
3/4	7	3/8
1	7	3/8
1-1/2	9	3/8
2	10	3/8
2-1/2	11	1/2
3	12	1/2
4	14	5/8
6	17	3/4
8	19	3/4
10	22	7/8
12	23	7/8
14	25	1
16	27	1
18	28	1
20	30	1-1/4
24	32	1-1/4

- .8 Pipe hangers must include rubber lining on the inside of the clamp to prevent pipe wear, unless the pipe is insulated.
- .9 Mechanical system shut-off valves:
- .1 All hand shutoff valves shall be ball valves or butterfly valves.
 - .2 Valve type used:
 - .1 1/4" to 2", threaded full port ball valves
 - .2 2 1/2" to 8", full lug type butterfly valves
 - .3 Ball valves to be two (2) piece construction with bronze or steel body, stainless steel ball and manual lever actuator with stem extension. Ball valves to have a rated working pressure or 600 PSIG.
 - .4 Butterfly valves to be full lug style and constructed with ductile iron body, ductile iron nickel plated disc, stainless steel shaft, and BUNA-N seat. Butterfly valve to have rated working pressure of 225 PSIG.
- .10 Valve flow coefficient shall be, at minimum, as per the following. Pressure drop across any fully open valve shall be at maximum 1.5 psi.

Pipe Size (in.)	CV
1-1/2	45
2	75
2-1/2	140
3	240
4	400
5	700
6	1000
8	2100
10	3100
12	4500

.11 Glycol Piping Insulation

- .1 Temperature range: Any
- .2 Insulation Type: Polyiso
- .3 Thickness: 1"
- .4 Jacket Type: PVC
 - .1 Single piece, pre-curved for insulation thickness

.12 Water Piping Insulation

- .1 Temperature range: Any
- .2 Insulation Type: Polyiso
- .3 Thickness: 1"
- .4 Jacket Type: PVC
 - .1 Single piece, pre-curved for insulation thickness

.13 Unless otherwise indicated, all materials must be new, first quality and approved by at least one of the following organizations: ULC, ARI, AMCA, ASME or any other body with jurisdiction in the area concerned.

.14 Piping system test pressures:

- .1 All new piping to be pressure tested. Provide all test results to Owner upon completion.
- .2 Type of test: Hydronic
- .3 Cold Glycol System: 80 PSI.
- .4 Warm Glycol System: 100 PSI.

6.9 Specific Requirements

- .1 The proponent is responsible for:
 - .1 All pipe, valves and fittings shall be installed as per Local, State, and National Code.
 - .2 Construction is to be completed in conjunction with owner.

6.10 Installation Practices

- .1 All piping shall be installed as per manufacturer’s specifications in accordance with ASME B31.9 as required.
- .2 All piping shall be installed straight and true, and parallel to all walls.
- .3 All valves and controls should be located at ergonomic heights unless technically unfeasible.
- .4 All valves shall be tagged with identification tags, and a reference key identifying each valve shall be provided with the as-built drawings.
- .5 Piping shall be installed as per the drawings package.
- .6 Piping installed in public spaces shall be located inside a metallic mesh cage to prevent damage and unauthorized access.

PART 7 – REFRIGERANT
PIPING

7.1 Refrigerant Piping
General Comments

- .1 All work of this Division shall be coordinated and provided by the Mechanical Contractor.
- .2 All materials shall be first class and new.
- .3 The Refrigeration Contractor shall work with the facility, and the Consultant to provide completed refrigeration piping in a timely manner.
- .4 The work of this Division shall be as required by the Specifications and Schematic.
- .5 If the Contractor believes there are conflicts or missing information in the project documents, the Contractor shall promptly request clarification and instruction from the design team.
- .6 The following specification is for the refrigerant relief piping from the new refrigeration package(s).

7.2 Refrigerant Piping
Definitions

- .1 Refrigerant Piping: Piping which contains refrigerant as any stage within the refrigeration cycle.
- .2 Refrigerant Relief Piping: Piping specifically used to vent refrigerant to atmosphere, in the event of an emergency or for testing purposes.
- .3 Refrigeration Contractor (or Contractor): The Contractor responsible for supply and installation of all refrigerant piping components and requirements as specified.

7.3 Refrigerant Piping
Description

- .1 The supply and installation of refrigerant piping, labeling, identification and insulation as outlined.
 - .2 The work shall consist of the provision of all labour, materials, tools, equipment, testing, commissioning, training services, transportation, shipping, handling, administration, supervision, management, insurance, temporary protection, cleaning, cutting and patching, warranties, services, and items, even though these may not be specifically mentioned in this documents which are required for the complete, fully functional and commissioned refrigerant piping system.
-

- .3 Provide a complete, neat and workmanlike installation. Use only manufacturers and employees who are skilled, experienced, trained, and familiar with the specific equipment, software, standards and configurations to be provided for this Project.
- .4 Manage and coordinate the work in a timely manner in consideration of the Project schedules. Coordinate with the associated work of other trades so as to not impede or delay the work of associated trades.

7.4 Refrigerant Piping Quality Assurance

- .1 General
 - .1 The Refrigeration Contractor shall be a recognized national supplier, installer and service provider for refrigerant piping.
 - .2 As part of Risk Management and evidence and assurance of the contractor's ability to support the Owner's system with service and parts, the Contractor must have been in the business for at least the last ten (10) years and have successfully completed a total of ten (10) refrigerant piping systems in the preceding five (5) years.
 - .2 Workplace Safety and Hazardous Materials
 - .1 Provide a safety program in compliance with the Contract Documents.
 - .2 The Contractor shall have a corporately certified comprehensive Safety Certification Manual and a designated Safety Supervisor for the Project.
 - .3 The Contractor and its employees and subtrades comply with federal, state and local safety regulations.
 - .4 The Contractor shall ensure that all subcontractors and employees have written safety programs in place that covers their scope of work, and that their employees receive the training required by the Health and Safety Commission in the jurisdiction for at least each topic listed in the Safety Certification Manual.
 - .5 Hazards created by the Contractor or its subcontractors shall be eliminated before any further work proceeds.
 - .6 Hazards observed but not created by the Contractor or its subcontractors shall be reported to either the Consultant or the Owner within the same day. The Contractor shall be required to avoid the hazard area until the hazard has been eliminated.
 - .7 The Contractor shall sign and date a safety certification form prior to any work being performed, stating that the Contractors'
-

company is in full compliance with the Project safety requirements.

- .8 The Contractor's safety program shall include written policy and arrangements for the handling, storage and management of all hazardous materials to be used in the work in compliance with the requirements of the Authorities Having Jurisdiction at the Project site.
- .9 The Contractor's employees and subcontractor's staff shall have received training as applicable in the use of hazardous materials and shall govern their actions accordingly.

.3 Quality Management Program

- .1 Designate a competent and experienced employee to provide Project Management. The designated Project Manager shall be empowered to make technical, scheduling and related decisions on behalf of the Contractor. At minimum, the Project Manager shall:
 - .2 Manage the scheduling of the work to ensure that adequate materials, labour and other resources are available as needed.
 - .3 Manage the financial aspects of the Contract.
 - .4 Coordinate as necessary with other trades.
 - .5 Be responsible for the work and actions of the workforce on site.

7.5 Refrigerant Piping
Codes and Standards

- .1 Contractor to comply with all codes and standards applicable to this type of work, including;
 - .1 ASME B31.9 Building Service Piping
 - .2 ASME Boiler and Pressure Vessel Code
 - .3 Local, State and National Building Codes
 - .4 ASHRAE Standards
 - .5 OSHA Regulations
- .2 In the case of conflicts or discrepancies, the more stringent regulation shall apply.
- .3 All work shall meet the approval of the Authorities Having Jurisdiction at the project site.

7.6 Refrigerant Piping
Record
Documentation

- .1 Provide two (2) paper copies and one (1) electronic copy of as-built refrigerant piping schematics and layouts for all installed piping covered under this contract.
- .2 Manual shall be bound in 3 ring binders and contain, as a minimum, the following:

- .1 System operation and maintenance instructions, troubleshooting guidelines and operating log.
 - .2 Safety bulletins and material safety data sheets.
 - .3 Equipment operation and maintenance instructions.
 - .4 Signed Dept. of Labour (or equivalent) Pressure Tests Data Reports
 - .5 Shop drawings of all supplied equipment
- .3 As-built drawings shall contain, typical piping layout, material details, piping connection details, and any additional pertinent details regarding the piping.

7.7 Refrigerant Piping
Warranty

- .1 Standard Material and Labour Warranty:
- .1 The Contractor shall provide a one-year labour and material warranty from the date of substantial completion on the refrigerant piping system including all valves and fittings.
 - .2 If within twelve (12) months from the date of acceptance of product, upon written notice from the Owner, any portion of the Refrigerant Piping system is found to be defective in operation, workmanship or materials, it shall be replaced, repaired or adjusted at the option of the Contractor and at the cost of the Contractor.

7.8 Refrigerant Piping
Scope of Work

- .1 Refrigerant piping shall conform to ASME B31.5 Refrigeration piping code.
- .2 Refrigerant piping shall be as follows
- .2 Up to 1 1/2" IPS
 - .1 Schedule 80 ASTM A53 Grade A or B Seamless, OR
 - .2 Schedule 80 ASTM A106 Grade A or B Seamless, OR
 - .3 Schedule 80 ASTM A333 Grade 1 or 6 Seamless
 - .3 2" IPS and up
 - .1 Schedule 40 ASTM A53 Grade A or B ERW, OR
 - .2 Schedule 40 ASTM A106 Grade A or B Seamless, OR
 - .3 Schedule 40 ASTM A333 Grade 1 or 6 Seamless
 - .4 All piping shall bear the manufacturers identification and conform to the pervious specifications.
- .3 Refrigerant pipe fittings shall be as follows
- .2 Flanges ANSI & RF
 - .1 ASTM A105
 - .3 Pressure Rating to Match Design Working Pressure
 - .4 Up to 1 1/2" IPS
 - .1 Threaded – Forged Steel, ASTM A105, 3000 LBS
 - .2 Socket Weld – Forged Steel, ASTM A105, 3000 LBS

- .3 Butt Weld – Carbon Steel, ASTM SA-234-WPB E.H.
- .5 2" and Up
 - .1 Socket Weld – Forged Steel, ASTM A105, 3000 LBS
 - .2 Butt Weld – Carbon Steel, ASTM SA-234-WPB STD
- .4 Piping shall be identified as per the Refrigeration Pipe Labeling Guide:
 - .1 Labeling body shall be Black on Safety Yellow
 - .2 Labeling shall indicate flow of refrigerant and arrows shall be present on both sides of the label, with arrows wrapping around the entire circumference of the pipe
 - .3 Labeling shall have an abbreviation legend
 - .4 Labeling shall identify the system component as per the table listed below
 - .5 Labeling shall identify refrigerant physical state (Liquid or Vapour)
 - .1 Liquid shall be abbreviated as LIQ and set upon an Orange background
 - .2 Vapour shall be abbreviated as VAP and set upon a Blue background
 - .6 Labeling shall identify the working fluid as refrigerant
 - .7 Labeling shall identify pressure level
 - .1 LOW shall be any pressure below 70 psig and set upon a green background
 - .2 HIGH shall be any pressure above 70 psig and set upon a red background
 - .8 Label Size, text height and placement should conform to ASME A13.1
 - .1 Labels shall be adjacent to all valves and flanges
 - .2 Adjacent to all changes of direction
 - .3 On both sides of a wall or floor penetration
 - .4 At regular intervals on straight runs (maximum 50 feet spacing)
 - .1 BD Booster Discharge
 - .2 CD Condenser
 - .3 DS Defrost Condensate
 - .4 ES Economizer Suction
 - .5 HGD Hot Gas Defrost
 - .6 HPL High Pressure Liquid
 - .7 HSD High Stage Discharge
 - .8 HSS High Stage Suction
 - .9 HTRL High Temperature Recirculated Liquid
 - .10 HTRS High Temperature Recirculated Suction
 - .11 LTRL Low Temperature Recirculated Liquid

- .12 LTRS Low Temperature Recirculated Suction
- .13 LIC Liquid Injection Cooling
- .14 LSS Low Stage Suction
- .15 RV Relief Vent
- .16 TSR Thermosiphon Return
- .17 TSS Thermosiphon Supply

.5 Label Size, and Letter Size

Outside Pipe Diameter, including insulation (in)	Minimum Label Length (in)	Minimum Letter Height (in)
< 1.25	8	0.5
1.5 – 2	8	0.75
2.5 – 6	12	1.25
8 – 10	24	2.5
> 10	32	3.5

- .5 All insulated field fabricated steel piping shall be painted with a rust resistant primer prior to painting and insulation.
 - .1 Standard of Acceptance: Polyguard RG-2400 Primer, or approved equivalent.
- .6 To further protect the refrigerant piping, the piping shall be painted.
 - .1 Colors shall match existing color scheme currently utilized at the facility. If no color scheme is present, the following shall be used
 - .1 Red Compressor High Vapour
 - .2 Yellow Intermediate Pressure
 - .3 Orange High Pressure Liquid
 - .4 Blue Low Pressure Liquid or Vapour
 - .5 Green Water

.7 Refrigerant piping shall be supported as follows

Nominal Diameter Pipe NPS (in)	Recommended Spacing Between Hangers (ft.)	Recommended Rod Size (in)
1/2	7	3/8
3/4	7	3/8
1	7	3/8
1-1/2	9	3/8
2	10	3/8
2-1/2	11	1/2
3	12	1/2
4	14	5/8
6	17	3/4
8	19	3/4
10	22	7/8
12	23	7/8
14	25	1
16	27	1
18	28	1
20	30	1-1/4
24	32	1-1/4

.8 Refrigerant isolation valves to be Angle or Globe type only.

- .1 Supply and Return refrigerant valves to compressors shall be Angle type
 - .2 Supply and Return refrigerant valves to Plate and Frames shall be Globe type
 - .3 Supply and Return refrigerant valves to Condenser shall be Globe type
 - .4 Inline refrigerant valves shall be Globe type
- .9 All refrigerant valves to be equipped with seal caps; however, handwheels shall also be provided.

.10 Refrigerant Valve flow coefficient shall be, at minimum, as per the following

Pipe Size (in)	CV	Equivalent Pipe Length (ft.)
1-1/2	45	11
2	75	26
2-1/2	115	22
3	180	31
4	280	54
5	550	47
6	775	65
8	1300	85
10	2250	97
12	3000	116
14	4000	143
16	5500	155

.11 Refrigerant systems shall be equipped with Pressure Relief valves. The Relief Valves shall start to function at a pressure not exceeding the design pressure of the system being protected.

- .1 Stop Valves shall not be located between pressure relief valve and the system, unless when pressure relief valves are installed in parallel.
- .2 The discharge to atmosphere shall be not less than 15 ft. above the adjoining ground level, and not less than 20 ft. from any window, ventilation opening, pedestrian walkway, or exit.

.12 Unless otherwise indicated, all materials must be new, first quality and approved by at least one of the following organizations: ULC, ARI, AMCA, ASME or any other body with jurisdiction in the area concerned.

.13 All refrigerant piping and fittings shall conform to the latest edition of the ASME B31.5 Refrigeration Piping and Heat Transfer Components.

7.9 Refrigerant Piping Specific Requirements

- .1 The contractor shall provide a new refrigerant relief stack, which extends a minimum of 15 ft above the adjoining ground level and is 20 ft from any window, ventilation opening, pedestrian walkway, or building exit.

- .1 A diffusor and goose-neck must be included on the relief stack to prevent direct spray of refrigerant on personnel in the vicinity and prevent foreign material or debris from entering the discharge piping.
- .2 The proponent is responsible for:
 - .1 All pipe, valves and fittings shall be installed as per code. The pipe sizes and valve equipment list are provided in drawings package.
 - .2 Construction is to be completed in conjunction with the Owner.

7.10 Refrigerant Piping Installation Practices

- .1 All piping shall be installed as per manufacturer's specification.
 - .2 Where refrigerant piping must cross an open space that provides a passageway, piping shall be installed no less than 7.5 feet above floor, unless it is against the ceiling of such a space.
 - .3 All valves and controls should be located at ergonomic heights unless technically unfeasible.
 - .4 All piping shall be installed straight and true, and parallel to all walls.
 - .5 Refrigerant piping shall not be installed in an enclosed stairway, stair landing or exit. Piping shall not be installed in an elevator, dumb waiter, or shaft containing a moveable object.
 - .6 All refrigerant piping, valves, and fittings shall be free of copper, zinc and its specific alloys.
 - .7 All refrigerant valves shall be tagged with identification tags, and a reference key identifying each valve shall be located within the mechanical room.
 - .8 Piping and valves shall be installed as per the drawings package.
 - .9 Piping installed in public spaces shall be located inside a metallic mesh cage to prevent damage and unauthorized access.
-

PART 8 - ELECTRICAL
DESIGN-BUILD

8.1 Electrical Design-Build
Description

- .1 The design-build of an electrical system as outlined.
 - .2 The intent of the electrical design-build is that no loss of ice time will occur. This contractor must be able to demonstrate to the Owner that a proper plan be implemented such that the allotted time for installation is satisfied.
 - .1 If the start-up date for the electrical design-build does not occur by the substantial completion date, the Contractor will be responsible for supplying and installing temporary power at no cost to the Owner. The Contractor is responsible for all equipment selection and functionality in this scenario.
 - .2 At the option of the Contractor, temporary power may be provided in lieu of meeting the substantial completion date. This must be noted at the time of bidding and include all costs relating to switching-over the plant from the temporary to the permanent power. This must be approved by the Owner. The Contractor is responsible for all equipment selection and functionality within this option.
 - .3 Supply and install electrical design-build components, including wiring, panels, labour, and other electrical equipment.
 - .4 The work shall consist of the provision of all labour, materials, tools, equipment, testing, commissioning, transportation, shipping, handling, administration, supervision, management, insurance, temporary protection, cleaning, removal, installation, cutting and patching, warranties, services, and items, even though these may not be specifically mentioned in these documents which are required for the complete, fully functional, and commissioned electrical system.
 - .5 Provide a complete, neat, and workmanlike installation. Use only employees who are certified journeyman or registered apprentices (under the supervision of a journeyman). The labour used to carry out the work shall be skilled, experienced, trained, and is to be familiar with the specific equipment, software, standards, and configurations to be provided for this Project. Contractors must
-

8.2 Electrical Design-Build
Scope of Work

- submit registration numbers for key personnel that are certified journeyman.
- .6 Manage and coordinate the work in a timely manner in consideration of the Project schedule.
- .1 The Contractor shall provide a design-build electrical scope to provide all required electrical feed for the new refrigeration plant under this project.
- .1 The contractor is to confirm that the existing service is large enough for the new refrigeration system as part of the electrical design-build.
- .2 The electrical requirements of the plant are provided in 24-009 E-701 SPD Single Line Diagram.
- .3 The Contractor is to pull from the main building electrical a new feed per the conceptual design sized and verified by the Contractor's team for the refrigeration plant equipment, instrumentation, and controllers.
- .4 All wiring and conduit from electrical panels directly to equipment and instrumentation, including controllers, is the responsibility of the Contractor of this division.
- .1 The Contractor is responsible for verifying the existing electrical system on-site prior to bidding and determining what is required electrically to install the new system.
- .5 Power and control wiring as much as possible is to be run through the building in non-accessible locations to the building occupants in the most aesthetically pleasing method as reasonable.
- .1 Power and control wiring shall be run in conduit as much as possible
- .2 Power and control wiring shall be firmly secured to surfaces, walls, cable trays or other.
- .3 Power and control wiring is to be run parallel along walls at a minimum elevation of 7 ft in occupied corridors or along the ceiling of these zones to prevent interference with building occupants.
- .6 Any disagreements between these requirements and relevant Electrical Codes for the local municipality are trumped by the Electrical Codes.
- .7 The contractor is responsible for all required new electrical equipment. Reconfiguration is required to provide adequate power to the new equipment.

Appendix B

Contract Drawing Package



WWW.IBSTOREY.COM

IBS DRAWING SHEET DEFINITION

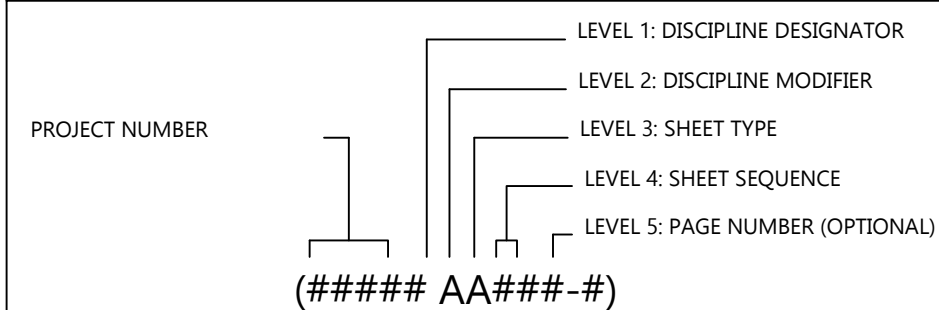

LEVEL 1 DISCIPLINE DESIGNATOR		LEVEL 2 DISCIPLINE MODIFIER		LEVEL 3 SHEET TYPE		LEVEL 4 SHEET SEQUENCE	
A	ARCHITECTURAL	-	MODIFIER NOT USED	0	GENERAL	01-99	SEQUENTIAL VALUE
B	GEOTECHNICAL	M	B	1	PLANS	ODD	DISTINCT DRAWINGS
C	CIVIL		D	2	ELEVATIONS	EVEN	MIRROR DRAWINGS
D	PROCESS		H	3	SECTIONS		
E	ELECTRICAL		I	4	LARGE-SCALE VIEWS		
F	FIRE PROTECTION		P	5	DETAILS		
H	HAZARDOUS MATERIALS		R	6	SCHEDULES & DIAGRAMS		
I	INTERIORS			7	COORDINATION		
L	LANDSCAPE			8	DESIGN STANDARD		
M	MECHANICAL			9	3D REPRESENTATIONS		
O	OPERATIONS						
P	PLUMBING						
Q	EQUIPMENT						
R	RESOURCE						
S	STRUCTURAL						
T	TELECOMMUNICATIONS						
V	SURVEY/MAPPING						
W	DISTRIBUTED ENERGY						
X	OTHER DISCIPLINES						
Z	CONTRACTOR/SHOP DRAWINGS						

REVISION LOG				
DRAWING #	DRAWING NAME	VER:	ISSUED FOR:	DATE
24009 M-601	SCHEMATICS & SCHEDULES	VER: 2.0	ISSUED FOR DETAILED DESIGN	05-SEP-24
24009 M-103	ADIABATIC FLUID COOLER PLACEMENT	VER: 1.0	ISSUED FOR DETAILED DESIGN	05-SEP-24
24009 M-401	EQUIPMENT LAYOUT	VER: 4.0	ISSUED FOR DETAILED DESIGN	05-SEP-24
24009 M-403	PLANT ROOM VIEWS	VER: 4.0	ISSUED FOR DETAILED DESIGN	05-SEP-24
24009 M-901	PLANT ROOM ISO VIEW	VER: 2.0	ISSUED FOR DETAILED DESIGN	05-SEP-24
24009 MP403	PLANT ROOM COOLING PIPING LARGE-SCALE VIEW	VER: 1.0	ISSUED FOR DETAILED DESIGN	05-SEP-24
24009 MP405	PLANT ROOM WARM PIPING LARGE-SCALE VIEW	VER: 1.0	ISSUED FOR DETAILED DESIGN	05-SEP-24
24009 MP407	PLANT ROOM RELIEF PIPING LARGE-SCALE VIEW	VER: 1.0	ISSUED FOR DETAILED DESIGN	05-SEP-24
24009 MP409	PLANT ROOM WATER PIPING LARGE-SCALE VIEW	VER: 1.0	ISSUED FOR DETAILED DESIGN	05-SEP-24
24009 MP411	SNOW MELT PIT PIPING LARGE-SCALE VIEW	VER: 1.0	ISSUED FOR DETAILED DESIGN	05-SEP-24
24009 MP903	COOLING PIPING ISOMETRIC VIEW	VER: 1.0	ISSUED FOR DETAILED DESIGN	05-SEP-24
24009 MP905	HEATING PIPING ISOMETRIC VIEW	VER: 1.0	ISSUED FOR DETAILED DESIGN	05-SEP-24
24009 MP907	RELIEF PIPING ISOMETRIC VIEW	VER: 1.0	ISSUED FOR DETAILED DESIGN	05-SEP-24
24009 MP909	WATER PIPING ISOMETRIC VIEW	VER: 1.0	ISSUED FOR DETAILED DESIGN	05-SEP-24
24009 M-603	BACKUP CONTROLLER SCHEMATIC	VER: 1.0	ISSUED FOR DETAILED DESIGN	05-SEP-24
24009 MI101	AUTOMATION PLAN	VER: 2.0	ISSUED FOR DETAILED DESIGN	05-SEP-24
24009 MI601	AUTOMATION SCHEMATICS	VER: 2.0	ISSUED FOR DETAILED DESIGN	05-SEP-24
24009 MR101	RINK FLOOR LAYOUT	VER: 2.0	ISSUED FOR DETAILED DESIGN	05-SEP-24
24009 MR401	RINK FLOOR LARGE-SCALE VIEWS	VER: 2.0	ISSUED FOR DETAILED DESIGN	05-SEP-24
24009 MR503	RINK FLOOR DETAILS	VER: 4.0	ISSUED FOR DETAILED DESIGN	05-SEP-24
24009 MB101	BOARDS & GLASS PLAN	VER: 2.0	ISSUED FOR DETAILED DESIGN	05-SEP-24
24009 MB503	BOARDS & GLASS DETAILS	VER: 4.0	ISSUED FOR DETAILED DESIGN	05-SEP-24
24009 E-701	SINGLE LINE DIAGRAM	VER: 2.0	ISSUED FOR DETAILED DESIGN	05-SEP-24
24009 S-701	EQUIPMENT WEIGHTS & HOUSEKEEPING PADS	VER: 1.0	ISSUED FOR DETAILED DESIGN	05-SEP-24
24009 P-701	PLUMBING COORDINATION	VER: 1.0	ISSUED FOR DETAILED DESIGN	05-SEP-24
24009 SPEC 1	RINK ENGINEERING TENDER SPECIFICATION	VER: 1.0	ISSUED FOR DETAILED DESIGN	05-SEP-24
IBSDS M801	GLYCOL RELIEF VALVES STANDARD	VER: 10.0	ISSUED FOR DETAILED DESIGN	30-AUG-24
IBSDS M805	AIR SEPARATOR STANDARD	VER: 12.0	ISSUED FOR DETAILED DESIGN	30-AUG-24
IBSDS M809	GLYCOL FEEDER STANDARD	VER: 10.0	ISSUED FOR DETAILED DESIGN	30-AUG-24
IBSDS M811	EXPANSION TANK STANDARD	VER: 11.0	ISSUED FOR DETAILED DESIGN	30-AUG-24
IBSDS M815	RENTAL CHILLER STANDARD	VER: 4.0	ISSUED FOR DETAILED DESIGN	27-MAR-24

REVISION LOG

NOTES

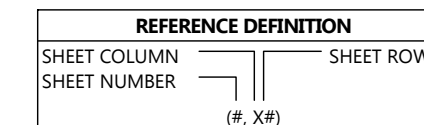

COPYRIGHT AND DISCLAIMER

THIS WORK IS THE SOLE PROPERTY OF I.B. STOREY INC AND IS INTENDED SOLELY FOR THE INFORMATION OF THE CLIENT. ALL RIGHTS RESERVED. THE WORK MAY NOT BE REPRODUCED OR DISTRIBUTED, WHOLE OR IN PART, WITHOUT THE PRIOR WRITTEN PERMISSION OF I.B. STOREY INC. THIS DOCUMENT MAY NOT BE USED FOR ANY OTHER PROJECTS OR WITHOUT INVOLVEMENT OF I.B. STOREY INC. ANY USE WHICH A THIRD PARTY MAKES OF THE WORK, OR ANY RELIANCE ON OR DECISIONS TO BE MADE BASED ON IT, ARE THE RESPONSIBILITY OF SUCH THIRD PARTIES.

**- NOT FOR CONSTRUCTION -
CONFIDENTIAL & PROPRIETARY**

VER #	REVISIONS	DATE	BY
4.0	ISSUED FOR DETAILED DESIGN	05-SEP-24	H.A.
3.0	ISSUED FOR SCHEMATIC DESIGN	28-JUN-24	H.A.
2.0	ISSUED FOR CONCEPTUAL DESIGN	30-MAY-24	H.A.
1.0	ISSUED FOR WORKSHOP	06-MAY-24	H.A.



CHARLOTTETOWN PE
VAUGHAN ON
REDINGTON SHORES FL
PLANO TX

WWW.IBSTOREY.COM

STAMP

DRAWING NUMBER 24009 PKG01	
DRAWING NAME REVISION LOG	
CLIENT SPRINGFIELD PARK DISTRICT	
PROJECT SPRINGFIELD - PLANT REPLACEMENT	
DRAWN BY H.AKAR	CHECKED BY J.RITCHIE
DATE 05-SEP-24	REVISION 4.0
SHEET SIZE C	SHEET NO. 1 OF 1

24009 PKG01

1

2

3

4

5

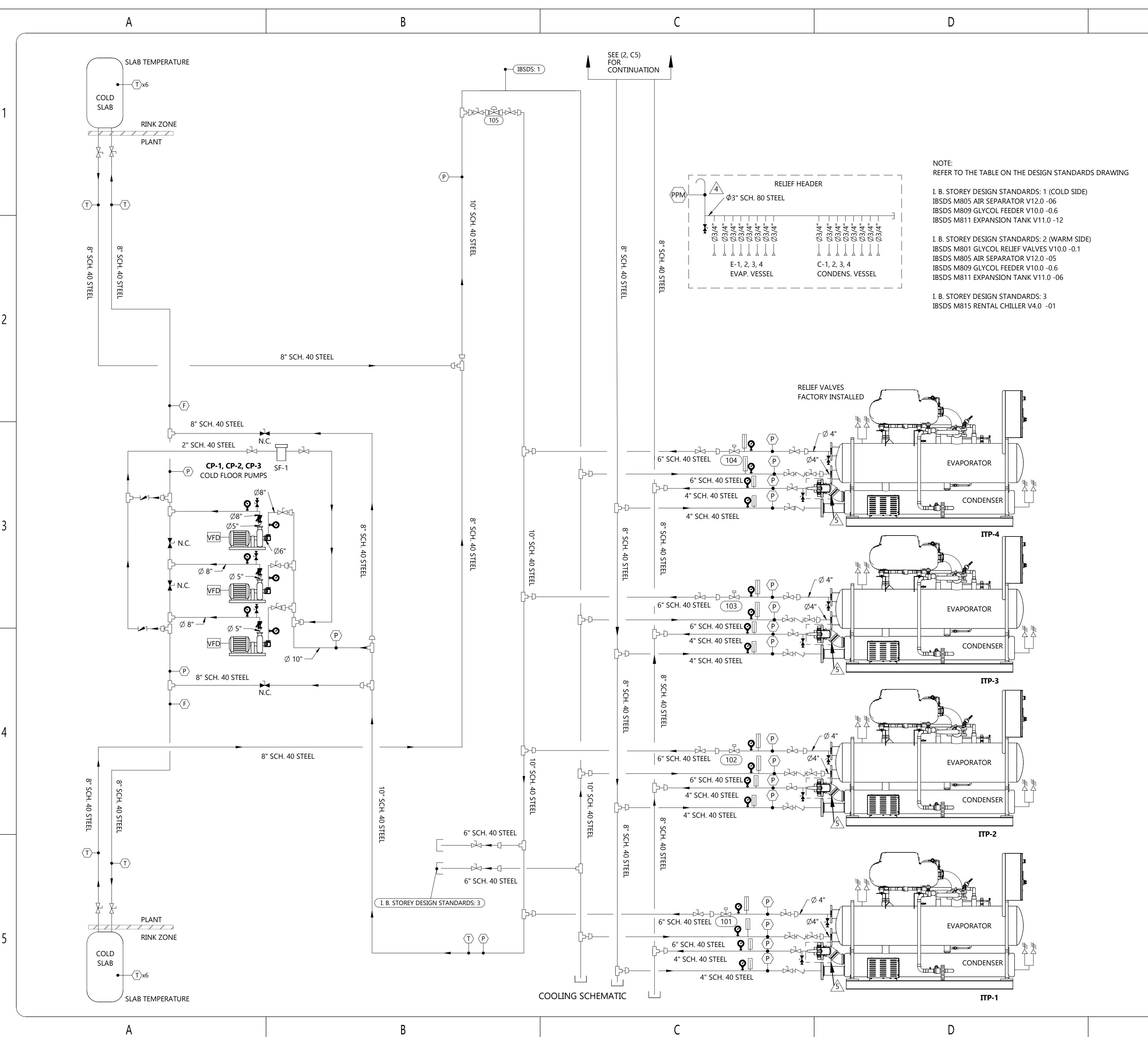

NOTES

NEW	EXISTING
	ISOLATING VALVE
	MODULATING VALVE
	SOLENOID VALVE
	EXPANSION VALVE
	RELIEF VALVE
	STRAINER
	CHECK VALVE
	BALANCING VALVE
	DRAIN
	FLO-TREX VALVE
	SUCTION GUIDE
	PRESSURE SENSOR
	TEMPERATURE SENSOR
	FLOW METER
	LEVEL SWITCH
	RELIEF LINE
	PRESSURE GAUGE
	THERMOMETER
	REFRIGERANT DETECTOR

REFERENCE DEFINITION

SHEET COLUMN	SHEET ROW
(#, X#)	

COPYRIGHT AND DISCLAIMER
THIS WORK IS THE SOLE PROPERTY OF I.B. STOREY INC AND IS INTENDED SOLELY FOR THE INFORMATION OF THE CLIENT. ALL RIGHTS RESERVED. THE WORK MAY NOT BE REPRODUCED OR DISTRIBUTED, WHOLE OR IN PART, WITHOUT THE PRIOR WRITTEN PERMISSION OF I.B. STOREY INC.
THIS DOCUMENT MAY NOT BE USED FOR ANY OTHER PROJECTS OR WITHOUT INVOLVEMENT OF I.B. STOREY INC. ANY USE WHICH A THIRD PARTY MAKES OF THE WORK, OR ANY RELIANCE ON OR DECISIONS TO BE MADE BASED ON IT, ARE THE RESPONSIBILITY OF SUCH THIRD PARTIES.

- NOT FOR CONSTRUCTION -
CONFIDENTIAL & PROPRIETARY

VER #	REVISIONS	DATE	BY
2.0	ISSUED FOR DETAILED DESIGN	05-SEP-24	H.A.
1.0	ISSUED FOR SCHEMATIC DESIGN	28-JUN-24	H.A.

I.B. STOREY
Rink Engineering Experts

CHARLOTTETOWN PE
VAUGHAN ON
REDINGTON SHORES FL
PLANO TX

WWW.IBSTOREY.COM

STAMP

DRAWING NUMBER	24009 M-601
DRAWING NAME	SCHEMATICS & SCHEDULES
CLIENT	SPRINGFIELD PARK DISTRICT
PROJECT	SPRINGFIELD - PLANT REPLACEMENT
DRAWN BY	H.AKAR
CHECKED BY	C.CUDMORE
DATE	05-SEP-24
REVISION	2.0
SHEET SIZE	C
SHEET NO.	1 OF 3

NOTES

NEW	EXISTING
	ISOLATING VALVE
	MODULATING VALVE
	SOLENOID VALVE
	EXPANSION VALVE
	RELIEF VALVE
	STRAINER
	CHECK VALVE
	BALANCING VALVE
	DRAIN
	FLO-TREX VALVE
	SUCTION GUIDE
	PRESSURE SENSOR
	TEMPERATURE SENSOR
	FLOW METER
	LEVEL SWITCH
	RELIEF LINE
	PRESSURE GAUGE
	THERMOMETER
	REFRIGERANT DETECTOR

REFERENCE DEFINITION

SHEET COLUMN	SHEET ROW
(#, X#)	

COPYRIGHT AND DISCLAIMER
 THIS WORK IS THE SOLE PROPERTY OF I.B. STOREY INC AND IS INTENDED SOLELY FOR THE INFORMATION OF THE CLIENT. ALL RIGHTS RESERVED. THE WORK MAY NOT BE REPRODUCED OR DISTRIBUTED, WHOLE OR IN PART, WITHOUT THE PRIOR WRITTEN PERMISSION OF I.B. STOREY INC.
 THIS DOCUMENT MAY NOT BE USED FOR ANY OTHER PROJECTS OR WITHOUT INVOLVEMENT OF I.B. STOREY INC. ANY USE WHICH A THIRD PARTY MAKES OF THE WORK, OR ANY RELIANCE ON OR DECISIONS TO BE MADE BASED ON IT, ARE THE RESPONSIBILITY OF SUCH THIRD PARTIES.
- NOT FOR CONSTRUCTION -
 CONFIDENTIAL & PROPRIETARY

2.0	ISSUED FOR DETAILED DESIGN	05-SEP-24	H.A.
1.0	ISSUED FOR SCHEMATIC DESIGN	28-JUN-24	H.A.
VER #	REVISIONS	DATE	BY

I.B. STOREY
 Risk Engineering Experts

CHARLOTTETOWN PE
 VAUGHAN ON
 REDINGTON SHORES FL
 PLANO TX

WWW.IBSTOREY.COM

STAMP

DRAWING NUMBER	24009 M-601
DRAWING NAME	SCHEMATICS & SCHEDULES
CLIENT	SPRINGFIELD PARK DISTRICT
PROJECT	SPRINGFIELD - PLANT REPLACEMENT
DRAWN BY	H.AKAR
CHECKED BY	C.CUDMORE
DATE	05-SEP-24
REVISION	2.0
SHEET SIZE	C
SHEET NO.	2 OF 3

1	STRUCTURAL SUPPORT, CONCRETE PAD, AND PLUMBING TO DRAIN BY OTHERS.
2	COLD GLYCOL PIPING TO BE INSULATED AS PER TENDER SPECIFICATIONS.
3	FACILITY DOMESTIC COLD WATER CONNECTIONS BY OTHERS.
4	THE POINT OF VENT DISCHARGE SHALL BE LOCATED NOT LESS THAN 15 FT ABOVE THE ADJOINING GROUND LEVEL. THE POINT OF VENT DISCHARGE SHALL BE LOCATED NOT LESS THAN 20 FT FROM WINDOWS, BUILDING VENTILATION OPENINGS, PEDESTRIAN WALKWAYS, OR BUILDING EXITS.
5	MODULATING CONDENSER VALVE (FACTORY INSTALLED)

HEATING SCHEMATIC

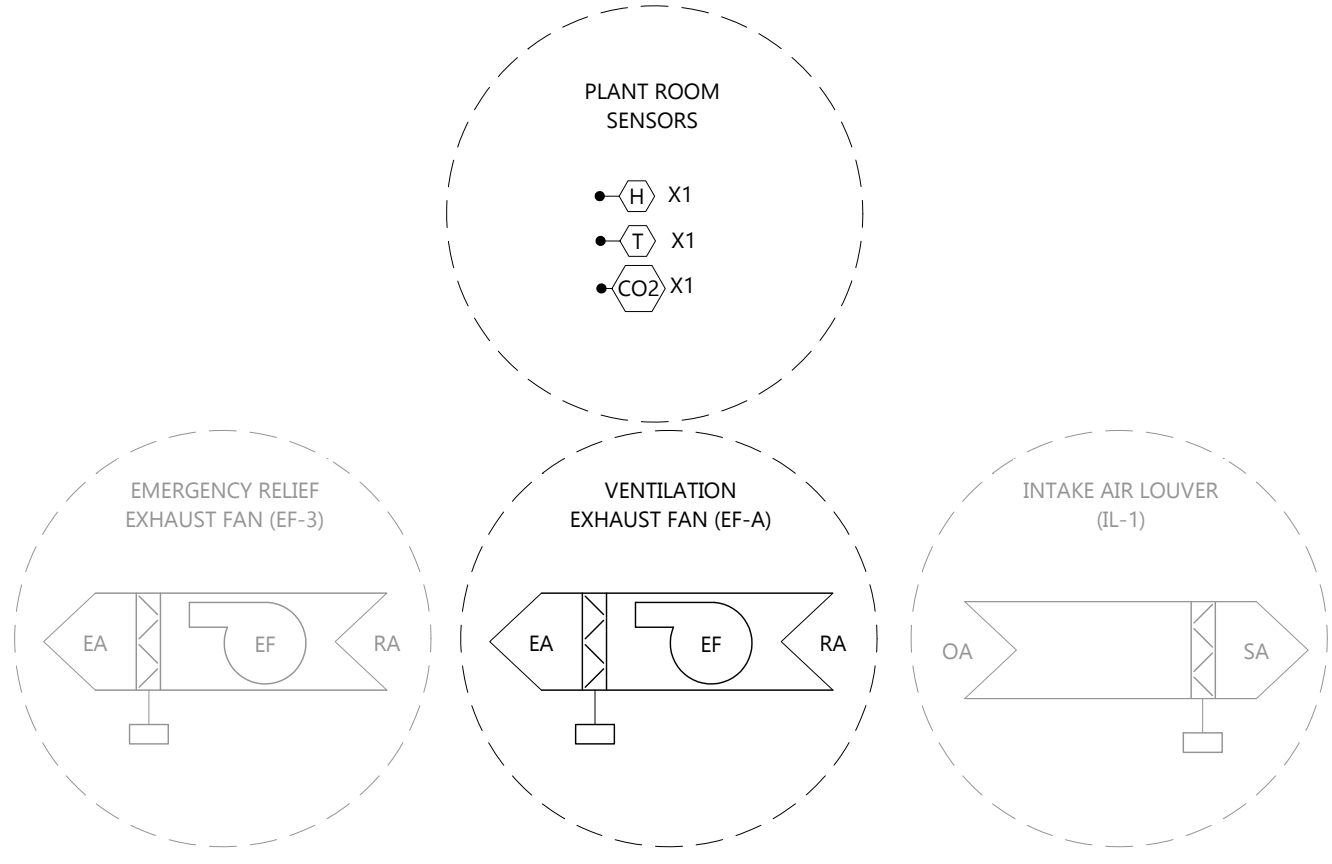
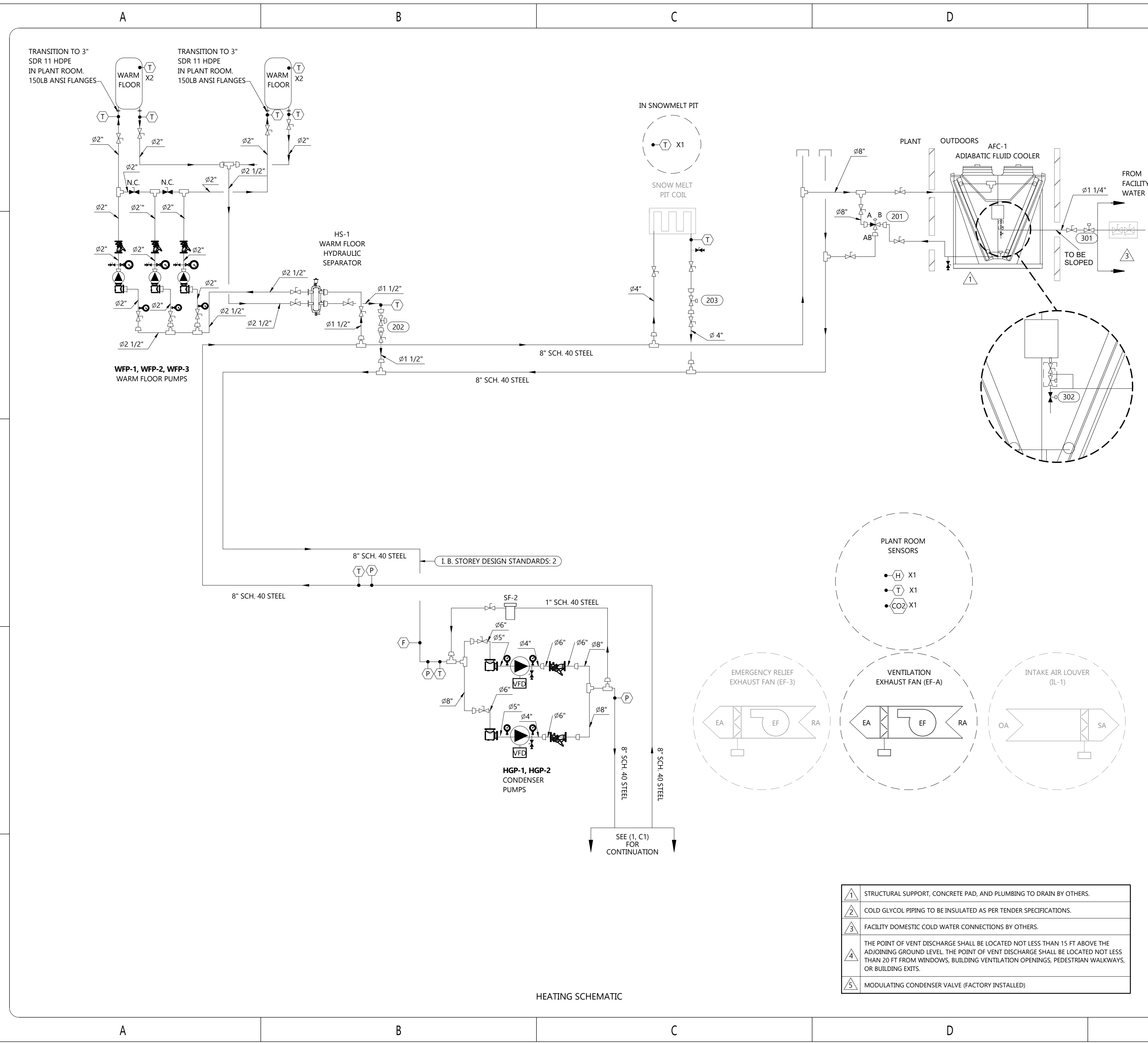

1

2

3

4

5

1

2

3

4

5

A

B

C

D

E

ITP PACKAGE SCHEDULE (ICE BUILDING MODE)

TAG	SERVICE	QTY	REFRIGERANT	COMPRESSOR DATA		CAPACITY, TR	EVAPORATOR DATA					CONDENSER DATA					POWER (KW)	V/PH/HZ	MANUFACTURER AND MODEL NO.
				NO. COMPRESSORS	NO. CIRCUITS		GPM	FLUID	EGT, F	LGT, F	FT. H2O	GPM	FLUID	EGT, F	LGT, F	FT. H2O			
ITP-1	INTEGRATED THERMAL PKG	1	R513A	1	1	50	467	40% E. GLYCOL	13	10	33	220	40% E. GLYCOL	85	93	25	52.8	460/3/60	THERMAL CARE TCFW375 LIMITED
ITP-2	INTEGRATED THERMAL PKG	1	R513A	1	1	50	467	40% E. GLYCOL	13	10	33	220	40% E. GLYCOL	85	93	25	52.8	460/3/60	THERMAL CARE TCFW375 LIMITED
ITP-3	INTEGRATED THERMAL PKG	1	R513A	1	1	50	467	40% E. GLYCOL	13	10	33	220	40% E. GLYCOL	85	93	25	52.8	460/3/60	THERMAL CARE TCFW375 LIMITED
ITP-4	INTEGRATED THERMAL PKG	1	R513A	1	1	50	467	40% E. GLYCOL	13	10	33	220	40% E. GLYCOL	85	93	25	52.8	460/3/60	THERMAL CARE TCFW375 LIMITED

DESIGN																
TAG	SERVICE	QTY.	MFR.	MODEL	FLOW, GPM	CAPACITY, MBH	AIR FLOW, CFM	DRY BULB TEMP, F	WET BULB TEMP, F	DRY SWITCH POINT, F	FLUID	EFT, F	LFT, F	PRESSURE DROP, PSIG	DIMENSIONS, LxWxH (FT)	OPERATING WEIGHT, LBS
AFC-1	ADIABATIC FLUID COOLER	1	GUNTNER	GFD 090.2A2x5/6AA-E355L/02P.M	680	3076	171549	90.6	75.9	79.6	40% EG	105	95	6.37	24x8.5x9.3	11450

PUMPS SCHEDULE

TAG	SERVICE	QTY.	FLUID	FLOW, GPM	FT. H2O	MOTOR HP	RPM	V/PH/HZ	VFD	EST. WEIGHT, LB	LxWxH, IN	MANUFACTURER AND MODEL NO.	SUCTION GUIDE	FLO TREX
CP-1	COLD FLOOR PUMP	1	40% E. GLYCOL	934	86.5	30	1750	480/3/60	YES	1334	48x19x28	ARMSTRONG 4030 6x5x11.5	SG-86	FTV-8FS
CP-2	COLD FLOOR PUMP	1	40% E. GLYCOL	934	86.5	30	1750	480/3/60	YES	1334	48x19x28	ARMSTRONG 4030 6x5x11.5	SG-86	FTV-8FS
CP-3	COLD FLOOR PUMP	1	40% E. GLYCOL	934	86.5	30	1750	480/3/60	YES	1334	48x19x28	ARMSTRONG 4030 6x5x11.5	SG-86	FTV-8FS
HGP-1	CONDENSER PUMP	1	40% E. GLYCOL	660	91	25	1721	480/3/60	YES	941	48x19x26.5	ARMSTRONG 4030 5x4x10	SG-65	FTV-6FS
HGP-2	CONDENSER PUMP	1	40% E. GLYCOL	660	91	25	1721	480/3/60	YES	941	48x19x26.5	ARMSTRONG 4030 5x4x10	SG-65	FTV-6FS
WFP-1	WARM FLOOR PUMP	1	40% E. GLYCOL	31	36.1	1	1735	480/3/60	NO	109	30x14x14.75	ARMSTRONG 4030 - 1.5x1x6	SG-1515TF	FTV-2GS
WFP-2	WARM FLOOR PUMP	1	40% E. GLYCOL	31	36.1	1	1735	480/3/60	NO	109	30x14x14.75	ARMSTRONG 4030 - 1.5x1x6	SG-1515TF	FTV-2GS
WFP-3	WARM FLOOR PUMP	1	40% E. GLYCOL	31	36.1	1	1735	480/3/60	NO	109	30x14x14.75	ARMSTRONG 4030 - 1.5x1x6	SG-1515TF	FTV-2GS

I.B. STOREY DESIGN STANDARDS SCHEDULE

TAG	DESCRIPTION	QTY.	SERVICE/LOCATION ID	MAX.FLOW, USGPM	MANUFACTURER AND MODEL NO.	ACCEPTANCE VOLUME, USGAL	VOLUME, USGAL	SHIPPING WEIGHT, LB
EX-1	EXP. TANK	1	COLD SIDE	-	ARMSTRONG AX-260V	128	158	812
EX-2	EXP. TANK	1	WARM SIDE	-	ARMSTRONG AX-100V	48.5	60	218
AS-1	AIR SEPARATOR	1	COLD SIDE	1868	VASASME VA-10-U	-	-	390
AS-2	AIR SEPARATOR	1	WARM SIDE	880	VASAME VA-8-U	-	-	228
GF-1	FEEDER	1	COLD SIDE	-	AXIOM SF-100L	-	100	55
GF-2	FEEDER	1	WARM SIDE	-	AXIOM SF-100L	-	100	55

COLD GLYCOL VALVE SCHEDULE

TAG	DESCRIPTION	QTY.	FLOW, GPM	PIPE SIZE, IN	VALVE SIZE, IN	VALVE PATTERN	VALVE CV	FAIL STATE	PART #	MANUFACTURER	ACTUATOR CONTROL SIGNAL
101	EVAP	1	467	6	4	2-WAY	600	OPEN	6100HD + DKRX24-3-T	BELIMO	FLOATING / TWO-POSITION
102	EVAP	1	467	6	4	2-WAY	600	OPEN	6100HD + DKRX24-3-T	BELIMO	FLOATING / TWO-POSITION
103	EVAP	1	467	6	4	2-WAY	600	OPEN	6100HD + DKRX24-3-T	BELIMO	FLOATING / TWO-POSITION
104	EVAP	1	467	6	4	2-WAY	600	OPEN	6100HD + DKRX24-3-T	BELIMO	FLOATING / TWO-POSITION
105	STARTUP BYPASS	1	467	6	4	2-WAY	230	OPEN	6100HD + PKRXUP-MFT-T	BELIMO	MODULATING

WARM GLYCOL VALVE SCHEDULE

TAG	DESCRIPTION	QTY.	FLOW, GPM	PIPE SIZE, IN	VALVE SIZE, IN	VALVE PATTERN	VALVE CV	FAIL STATE	PART #	MANUFACTURER	ACTUATOR CONTROL SIGNAL
201	ADIABATIC FLUID COOLER BY-PASS	1	880	8	5	3-WAY	393	MFT PROGRAMMABLE, B-AB FAIL OPEN	F7125HD+PKRXUP-MFT-T	BELIMO	ANALOG MODULATING (0)2-10 VDC
202	UNDER FLOOR	1	12	1 1/2	1/2	2-WAY	7.4	SPRING RETURN, FAIL OPEN	B214+LF24-MFT US	BELIMO	FLOATING / TWO-POSITION
203	SNOW MELT	1	157	4	2 1/2	2-WAY	150	FAIL SAFE CLOSED (FSC) VBN2 ONLY	B264+AFRB24	BELIMO	FLOATING / TWO-POSITION

WATER VALVE SCHEDULE

TAG	DESCRIPTION	QTY.	FLOW, GPM	PIPE SIZE, IN	VALVE SIZE	VALVE PATTERN	VALVE CV	FAIL STATE	PART #	MANUFACTURER	ACTUATOR CONTROL SIGNAL
301	WATER IN	1	5	1 1/4	1/2	2-WAY	4.7	CLOSED	B213+LF24-MFT US	BELIMO	FLOATING / TWO-POSITION
302	WATER DRAIN	1	5	1/2	1/2	2-WAY	4.7	OPEN	B213+LF24-MFT US	BELIMO	FLOATING / TWO-POSITION

EXHAUST FAN SCHEDULE

TAG	AREA SERVED	MFG	MODEL	DRIVE TYPE	CFM	TOTAL EXTERNAL SP	FAN RPM	BHP	HP	V/C/P	SONES (INLET)	DBA	NOTES
EF-3	PLANT ROOM	GREENHECK	SBE-1L24	BELT	5,000	0.1	613	0.37	0.5	115/60/1	11.4	60	EXISTING EXHAUST FAN (EMERGENCY RELIEF)
EF-A	PLANT ROOM	GREENHECK	BAER-24-02-0305	BELT	395	0.1	502	0.09	0.25	115/60/1	22	73	NEW VENTILATION EXHAUST FAN

SIDE STREAM FILTER SCHEDULE

TAG	MODEL	SIZE	SIDE STREAM FLOW RATE	FILTER SIZE	VESSEL VOLUME
SF-1	PRM BFHBFH2DCSX	2"	100 GPM	POLYESTER FELT BAG #2 7-1/16" DIA X 32"L	-
SF-2	SFP-20	1"	10-20 GPM	20" DOE COTTON WOUND	0.8 GAL

WARM FLOOR HYDRAULIC SEPARATOR SCHEDULE

TAG	FLUID	QTY.	SIZE IN	CAPACITY, GPM	MANUFACTURER AND MODEL NO.
HS-1	40% E. GLYCOL	1	2.5	80	CALEFFI 548062A

EQUIPMENT SCHEDULES

NOTE:
• CONTRACTOR TO CONFIRM MECHANICAL ROOM EXHAUST FAN FUNCTIONALITY AND PERFORMANCE.

NOTES

REFERENCE DEFINITION	
SHEET COLUMN	SHEET ROW
SHEET NUMBER	(#, X#)

COPYRIGHT AND DISCLAIMER
THIS WORK IS THE SOLE PROPERTY OF I.B. STOREY INC AND IS INTENDED SOLELY FOR THE INFORMATION OF THE CLIENT. ALL RIGHTS RESERVED. THE WORK MAY NOT BE REPRODUCED OR DISTRIBUTED, WHOLE OR IN PART, WITHOUT THE PRIOR WRITTEN PERMISSION OF I.B. STOREY INC.
THIS DOCUMENT MAY NOT BE USED FOR ANY OTHER PROJECTS OR WITHOUT INVOLVEMENT OF I.B. STOREY INC. ANY USE WHICH A THIRD PARTY MAKES OF THE WORK, OR ANY RELIANCE ON OR DECISIONS TO BE MADE BASED ON IT, ARE THE RESPONSIBILITY OF SUCH THIRD PARTIES.

- NOT FOR CONSTRUCTION -
CONFIDENTIAL & PROPRIETARY



CHARLOTTETOWN PE
VAUGHAN ON
REDINGTON SHORES FL
PLANO TX

WWW.IBSTOREY.COM

STAMP

DRAWING NUMBER	24009 M-601
DRAWING NAME	SCHEMATICS & SCHEDULES
CLIENT	SPRINGFIELD PARK DISTRICT
PROJECT	SPRINGFIELD - PLANT REPLACEMENT
DRAWN BY	H.AKAR
CHECKED BY	C.CUDMORE
DATE	05-SEP-24
REVISION	2.0
SHEET SIZE	C
SHEET NO.	3 OF 3

24009 M-601

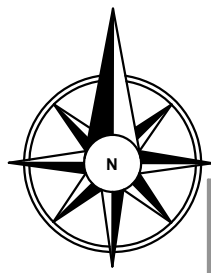

SITE KEY

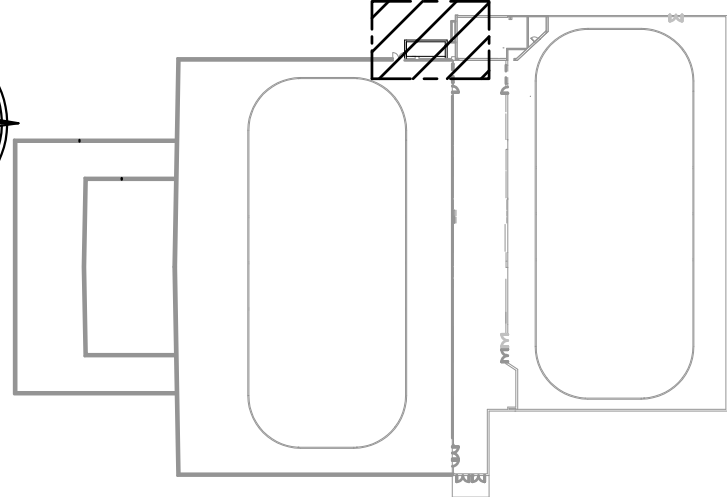

NOTE:

- ADIABATIC FLUID COOLER IS TO BE ELEVATED 4 FEET FROM THE GROUND TO ALLOW FOR ADEQUATE AIR FLOW.
- ADIABATIC FLUID COOLER TO HAVE AT LEAST 11 INCH CLEARANCE FROM THE SIDEWALL TO ALLOW FOR ADEQUATE AIRFLOW.
- ADIABATIC FLUID COOLER HAS A TOTAL OPERATING WEIGHT OF 11,450 LBS.
- REMOTE CONTROL PANEL LOCATED IN THE PLANT ROOM.
- PROTECTIVE FENCE TO BE INSTALLED WITHIN 1 FEET SURROUNDING THE ADIABATIC FLUID COOLER.

NOTES

	NEW
	EXISTING
	PROTECTIVE FENCING

REFERENCE DEFINITION	
SHEET COLUMN	SHEET ROW
SHEET NUMBER	(#, X#)

COPYRIGHT AND DISCLAIMER

THIS WORK IS THE SOLE PROPERTY OF I.B. STOREY INC AND IS INTENDED SOLELY FOR THE INFORMATION OF THE CLIENT. ALL RIGHTS RESERVED. THE WORK MAY NOT BE REPRODUCED OR DISTRIBUTED, WHOLE OR IN PART, WITHOUT THE PRIOR WRITTEN PERMISSION OF I.B. STOREY INC. THIS DOCUMENT MAY NOT BE USED FOR ANY OTHER PROJECTS OR WITHOUT INVOLVEMENT OF I.B. STOREY INC. ANY USE WHICH A THIRD PARTY MAKES OF THE WORK, OR ANY RELIANCE ON OR DECISIONS TO BE MADE BASED ON IT, ARE THE RESPONSIBILITY OF SUCH THIRD PARTIES.

- NOT FOR CONSTRUCTION -
CONFIDENTIAL & PROPRIETARY

1.0	ISSUED FOR DETAILED DESIGN	05-SEP-24	H.A.
VER #	REVISIONS	DATE	BY



CHARLOTTETOWN PE
VAUGHAN ON
REDINGTON SHORES FL
PLANO TX

WWW.IBSTOREY.COM

STAMP	
DRAWING NUMBER	
24009 M-103	
DRAWING NAME	
ADIABATIC FLUID COOLER PLACEMENT	
CLIENT	
SPRINGFIELD PARK DISTRICT	
PROJECT	
SPRINGFIELD - PLANT REPLACEMENT	
DRAWN BY	CHECKED BY
H.AKAR	J. RITCHIE
DATE	REVISION
05-SEP-24	1.0
SHEET SIZE	SHEET NO.
C	1 OF 1

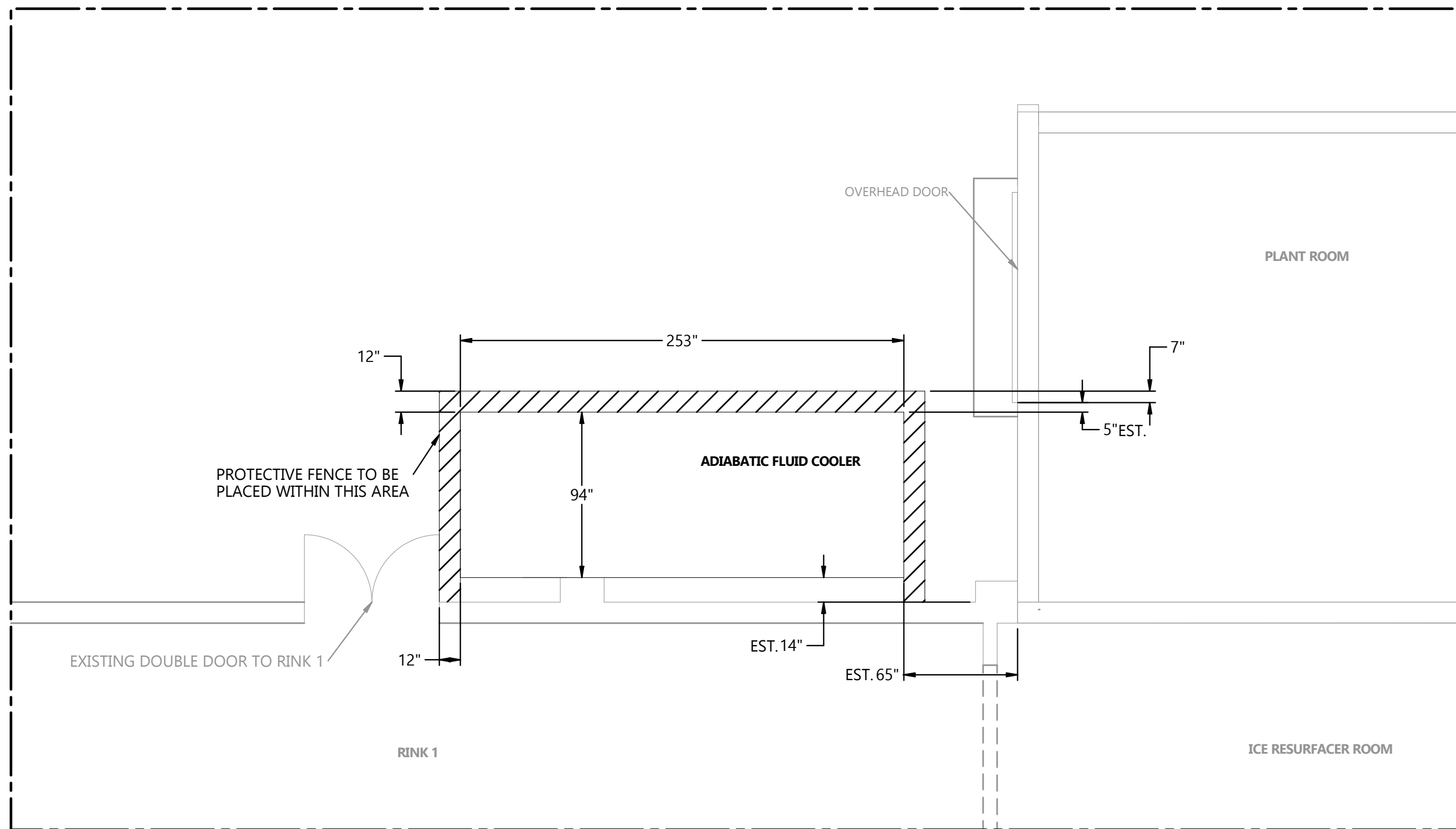

ADIABATIC FLUID COOLER PLACEMENT
SCALE 1"=16'

24009 M-103

1

2

3

4

5

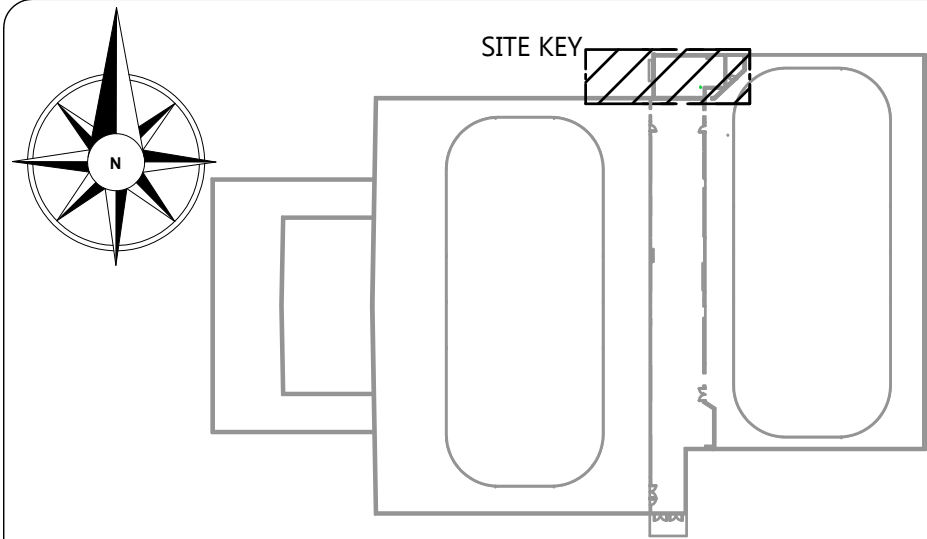

NOTES:

- ALL CONCRETE PADS SHOULD HAVE THICKNESS OF 4"
- ALL PIPING HIDDEN FOR CLARITY

NOTES

REFERENCE DEFINITION	
SHEET COLUMN	SHEET ROW
SHEET NUMBER	(#, X#)

COPYRIGHT AND DISCLAIMER
 THIS WORK IS THE SOLE PROPERTY OF I.B. STOREY INC AND IS INTENDED SOLELY FOR THE INFORMATION OF THE CLIENT. ALL RIGHTS RESERVED. THE WORK MAY NOT BE REPRODUCED OR DISTRIBUTED, WHOLE OR IN PART, WITHOUT THE PRIOR WRITTEN PERMISSION OF I.B. STOREY INC.
 THIS DOCUMENT MAY NOT BE USED FOR ANY OTHER PROJECTS OR WITHOUT INVOLVEMENT OF I.B. STOREY INC. ANY USE WHICH A THIRD PARTY MAKES OF THE WORK, OR ANY RELIANCE ON OR DECISIONS TO BE MADE BASED ON IT, ARE THE RESPONSIBILITY OF SUCH THIRD PARTIES.

- NOT FOR CONSTRUCTION -
CONFIDENTIAL & PROPRIETARY

VER #	REVISIONS	DATE	BY
4.0	ISSUED FOR DETAILED DESIGN	05-SEPT-24	H.D.
3.0	ISSUED FOR SCHEMATIC DESIGN	28-JUN-24	H.D.
2.0	ISSUED FOR CONCEPTUAL DESIGN	29-MAY-24	H.D.
1.0	ISSUED FOR WORKSHOP	06-MAY-24	H.D.



CHARLOTTETOWN PE
 VAUGHAN ON
 REDINGTON SHORES FL
 PLANO, TX

WWW.IBSTOREY.COM

STAMP

DRAWING NUMBER		24009 M-401	
DRAWING NAME		EQUIPMENT LAYOUT	
CLIENT		SPRINGFIELD PARK DISTRICT	
PROJECT		SPRINGFIELD-PLANT REPLACEMENT	
DRAWN BY	H.DHAMELIYA	CHECKED BY	J.RITCHIE
DATE	05-SEPT-24	REVISION	4.0
SHEET SIZE	C	SHEET NO.	1 OF 1

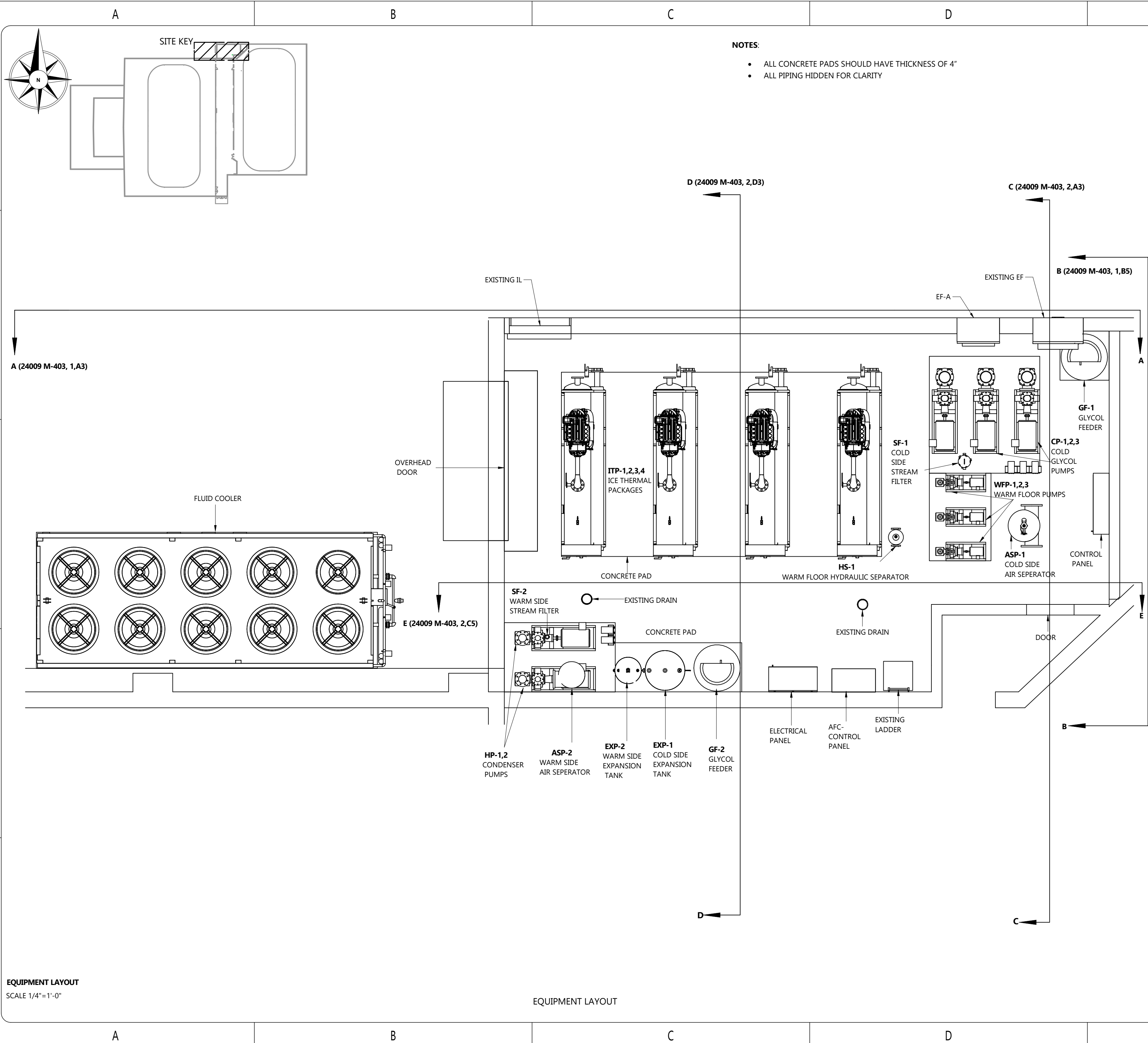

EQUIPMENT LAYOUT
 SCALE 1/4"=1'-0"

EQUIPMENT LAYOUT

24009 M-401

REFERENCE DEFINITION	
SHEET COLUMN	SHEET ROW
(#, X#)	

COPYRIGHT AND DISCLAIMER
 THIS WORK IS THE SOLE PROPERTY OF I.B. STOREY INC AND IS INTENDED SOLELY FOR THE INFORMATION OF THE CLIENT. ALL RIGHTS RESERVED. THE WORK MAY NOT BE REPRODUCED OR DISTRIBUTED, WHOLE OR IN PART, WITHOUT THE PRIOR WRITTEN PERMISSION OF I.B. STOREY INC.
 THIS DOCUMENT MAY NOT BE USED FOR ANY OTHER PROJECTS OR WITHOUT INVOLVEMENT OF I.B. STOREY INC. ANY USE WHICH A THIRD PARTY MAKES OF THE WORK, OR ANY RELIANCE ON OR DECISIONS TO BE MADE BASED ON IT, ARE THE RESPONSIBILITY OF SUCH THIRD PARTIES.

- NOT FOR CONSTRUCTION -
 CONFIDENTIAL & PROPRIETARY

VER #	REVISIONS	DATE	BY
4.0	ISSUED FOR DETAILED DESIGN	05-SEPT-24	H.D.
3.0	ISSUED FOR SCHEMATIC DESIGN	28-JUN-24	H.D.
2.0	ISSUED FOR CONCEPTUAL DESIGN	29-MAY-24	H.D.
1.0	RELEASED FOR WORKSHOP	06-MAY-24	H.D.



CHARLOTTETOWN PE
 VAUGHAN ON
 REDINGTON SHORES FL
 PLANO, TX

WWW.IBSTOREY.COM

STAMP

DRAWING NUMBER		24009 M-401	
DRAWING NAME		PLANT ROOM VIEWS	
CLIENT		SPRINGFIELD PARK DISTRICT	
PROJECT		SPRINGFIELD-PLANT REPLACEMENT	
DRAWN BY	H.DHAMELIYA	CHECKED BY	J.RITCHIE
DATE	05-SEPT-24	REVISION	4.0
SHEET SIZE	C	SHEET NO.	1 OF 2

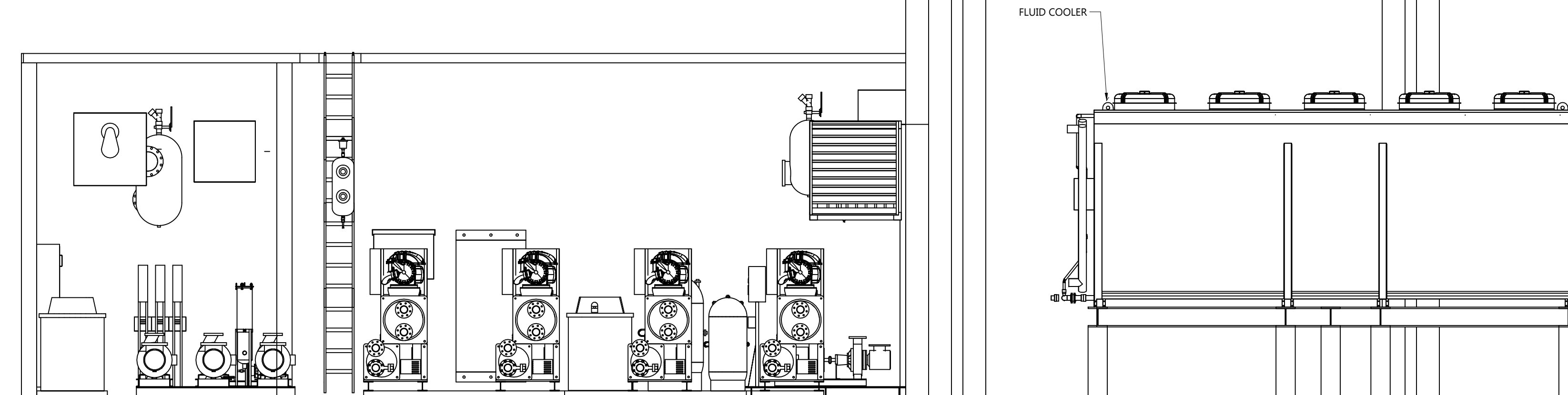

SECTION VIEW A-A (24009 M-401,1,A2) 180°
 SCALE 1/4"=1'-0"

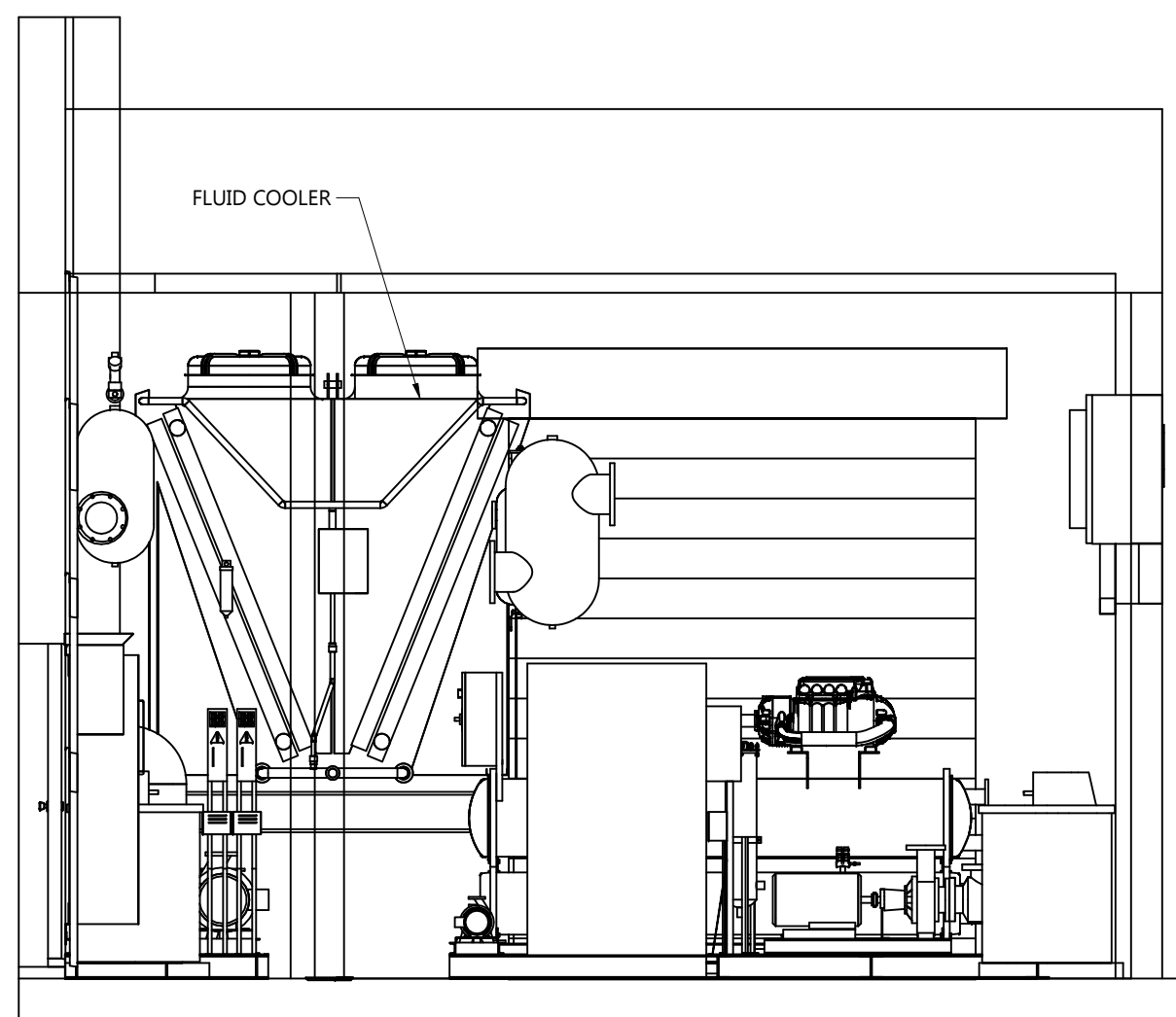

SECTION VIEW B-B (24009 M-401,1,D2) 90°
 SCALE 1/4"=1'-0"

PLANT ROOM VIEWS-1

NOTES:

- ALL CONCRETE PADS SHOULD HAVE THICKNESS OF 4"
- ALL PIPING ARE HIDDEN FOR CLARITY

NOTES:

- ALL CONCRETE PADS SHOULD HAVE THICKNESS OF 4"
- ALL PIPING HIDDEN FOR CLARITY

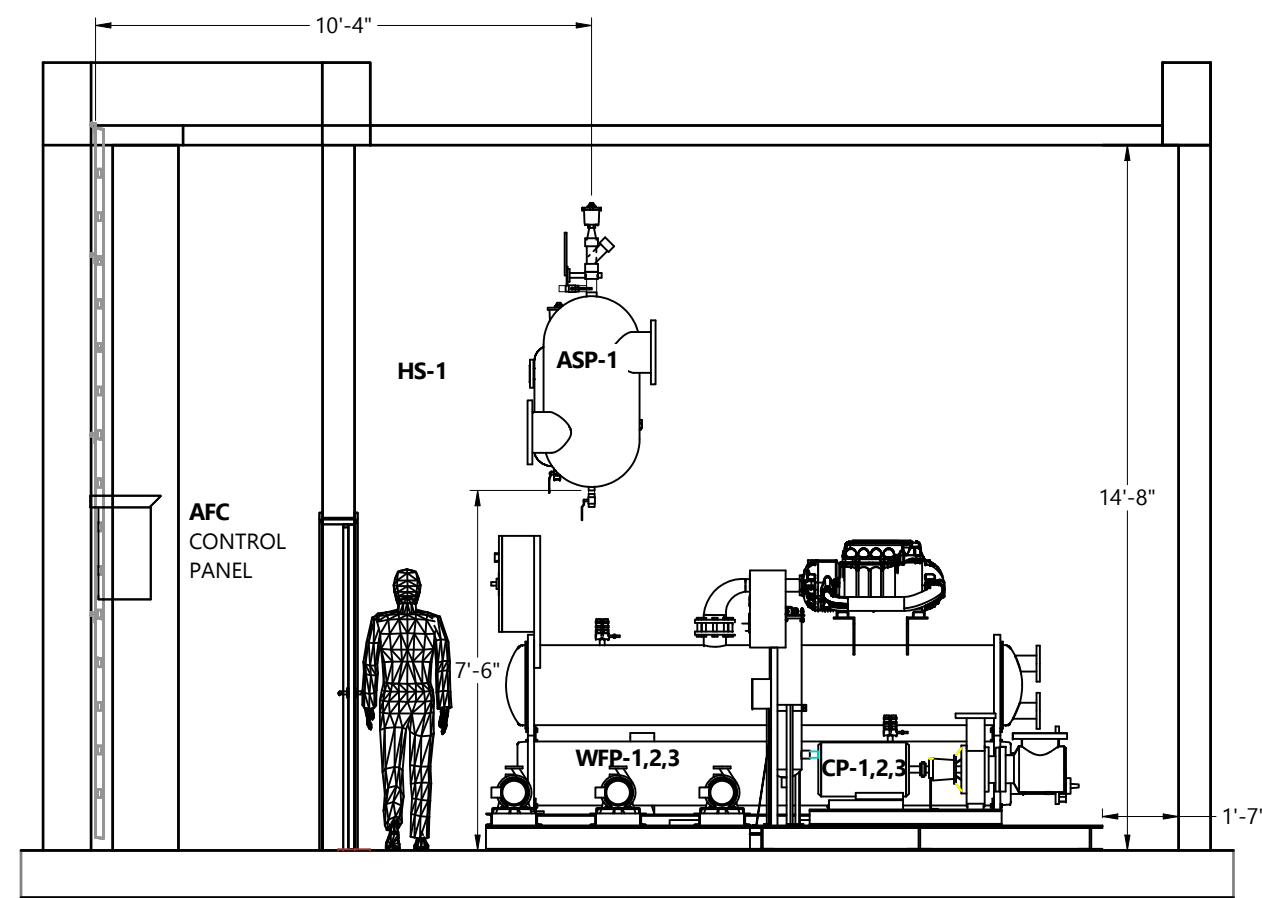

SECTION CUT C-C (24009 M-401,1,C1) 90°
SCALE 1/4"=1'-0"

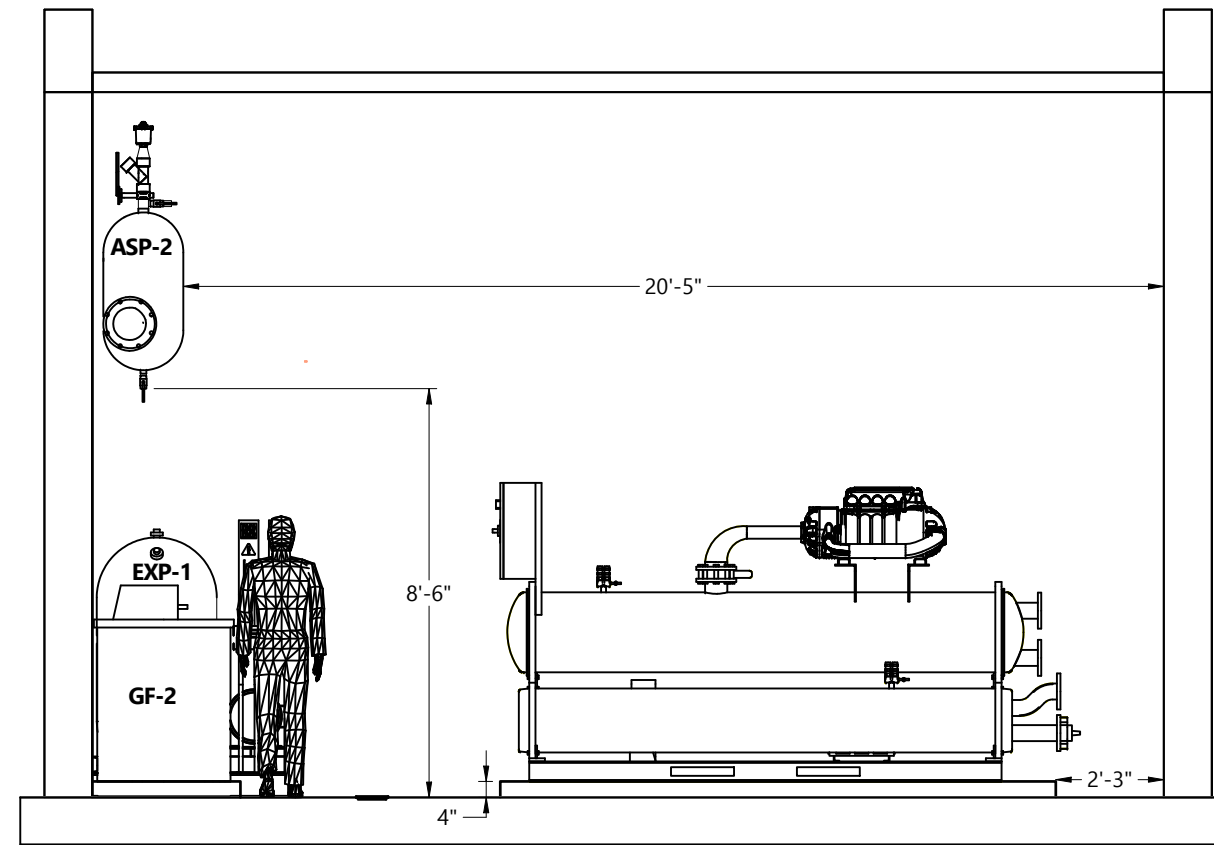

SECTION CUT D-D (24009 M-401,1,C2) 90°
SCALE 1/4"=1'-0"

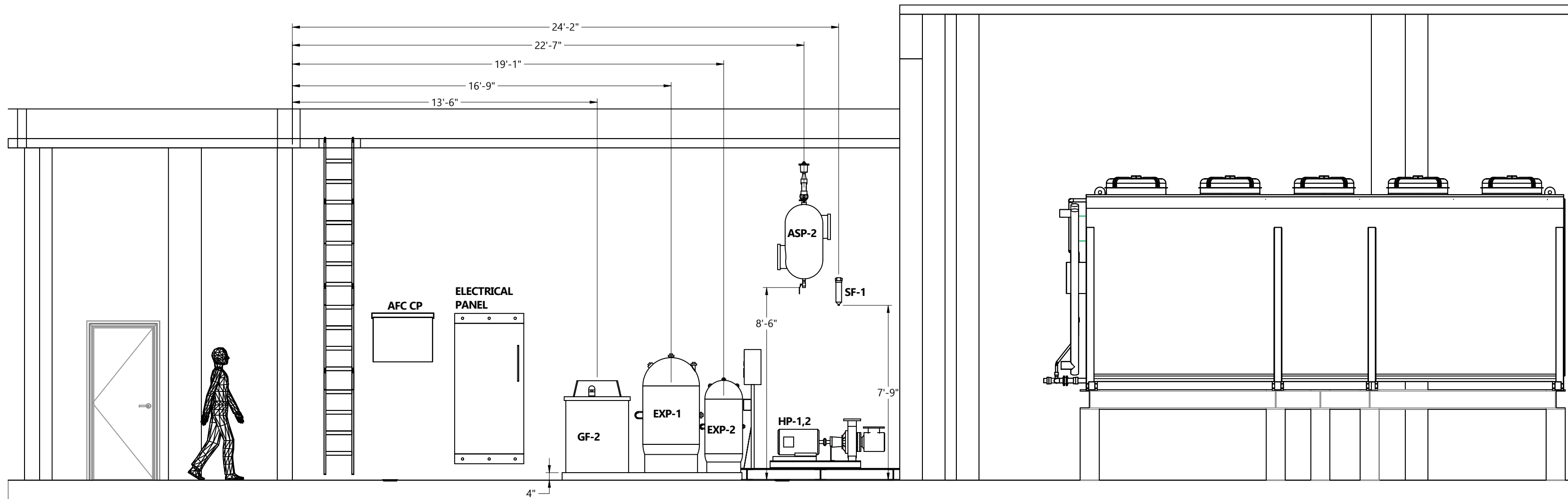

SECTION CUT E-E (24009 M-401,1,A4) 180°
SCALE 1/4"=1'-0"

PLANT ROOM VIEWS-2

NOTES

REFERENCE DEFINITION	
SHEET COLUMN	SHEET ROW
SHEET NUMBER	(#, X#)

COPYRIGHT AND DISCLAIMER
THIS WORK IS THE SOLE PROPERTY OF I.B. STOREY INC AND IS INTENDED SOLELY FOR THE INFORMATION OF THE CLIENT. ALL RIGHTS RESERVED. THE WORK MAY NOT BE REPRODUCED OR DISTRIBUTED, WHOLE OR IN PART, WITHOUT THE PRIOR WRITTEN PERMISSION OF I.B. STOREY INC.
THIS DOCUMENT MAY NOT BE USED FOR ANY OTHER PROJECTS OR WITHOUT INVOLVEMENT OF I.B. STOREY INC. ANY USE WHICH A THIRD PARTY MAKES OF THE WORK, OR ANY RELIANCE ON OR DECISIONS TO BE MADE BASED ON IT, ARE THE RESPONSIBILITY OF SUCH THIRD PARTIES.

- NOT FOR CONSTRUCTION -
CONFIDENTIAL & PROPRIETARY

VER #	REVISIONS	DATE	BY
4.0	ISSUED FOR DETAILED DESIGN	05-SEPT-24	H.D.
3.0	ISSUED FOR SCHEMATIC DESIGN	28-JUN-24	H.D.
2.0	ISSUED FOR CONCEPTUAL DESIGN	29-MAY-24	H.D.
1.0	RELEASED FOR WORKSHOP	06-MAY-24	H.D.



CHARLOTTETOWN PE
VAUGHAN ON
REDINGTON SHORES FL
PLANO, TX

WWW.IBSTOREY.COM

DRAWING NUMBER	
24009 M-401	
DRAWING NAME	
PLANT ROOM VIEWS	
CLIENT	
SPRINGFIELD PARK DISTRICT	
PROJECT	
SPRINGFIELD-PLANT REPLACEMENT	
DRAWN BY	CHECKED BY
H.DHAMELIYA	J.RITCHIE
DATE	REVISION
05-SEPT-24	4.0
SHEET SIZE	SHEET NO.
C	2 OF 2

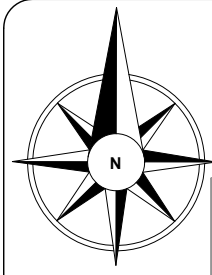

SITE KEY



1

2

3

4

5

A

B

C

D

E

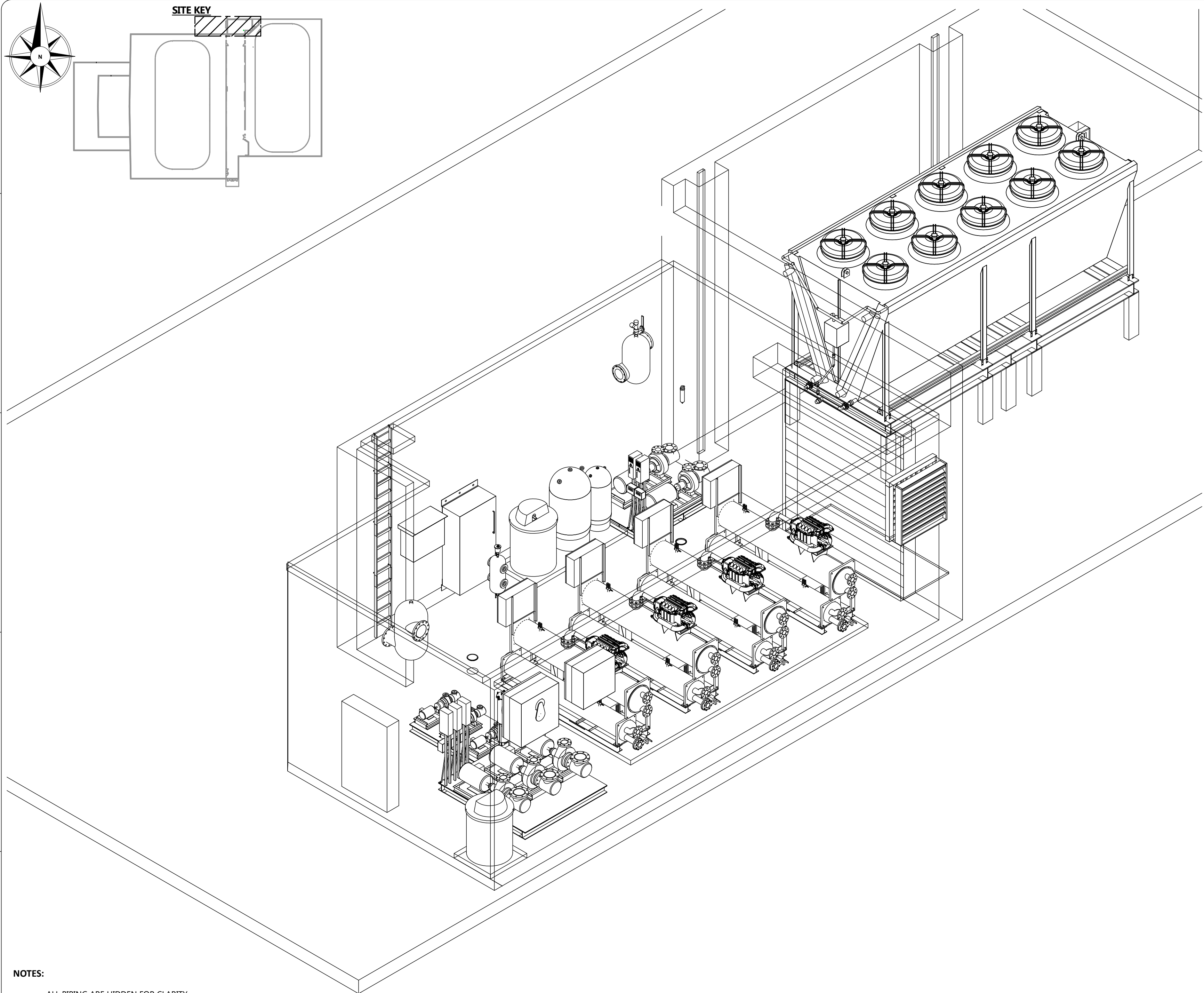

ISOMETRIC VIEW
SCALE 1/4"=1'-0"

PLANT ROOM ISOMETRIC VIEW

NOTES:

- ALL PIPING ARE HIDDEN FOR CLARITY.
- FOR EQUIPMENT TAGS REFER TO DWG NO 24009 M-401.

NOTES

REFERENCE DEFINITION	
SHEET COLUMN	SHEET ROW
SHEET NUMBER	(#, X#)

COPYRIGHT AND DISCLAIMER
 THIS WORK IS THE SOLE PROPERTY OF I.B. STOREY INC AND IS INTENDED SOLELY FOR THE INFORMATION OF THE CLIENT. ALL RIGHTS RESERVED. THE WORK MAY NOT BE REPRODUCED OR DISTRIBUTED, WHOLE OR IN PART, WITHOUT THE PRIOR WRITTEN PERMISSION OF I.B. STOREY INC.
 THIS DOCUMENT MAY NOT BE USED FOR ANY OTHER PROJECTS OR WITHOUT INVOLVEMENT OF I.B. STOREY INC. ANY USE WHICH A THIRD PARTY MAKES OF THE WORK, OR ANY RELIANCE ON OR DECISIONS TO BE MADE BASED ON IT, ARE THE RESPONSIBILITY OF SUCH THIRD PARTIES.

- NOT FOR CONSTRUCTION -
 CONFIDENTIAL & PROPRIETARY

VER #	REVISIONS	DATE	BY
2.0	ISSUED FOR DETAILED DESIGN	05-SEP-24	R.T.
1.0	ISSUED FOR SCHEMATIC DESIGN	28-JUN-24	H.D.



CHARLOTTETOWN PE
 VAUGHAN ON
 REDINGTON SHORES FL
 PLANO, TX

WWW.IBSTOREY.COM

STAMP

DRAWING NUMBER 24009 M-901	
DRAWING NAME PLANT ROOM ISOMETRIC VIEW	
CLIENT SPRINGFIELD PARK DISTRICT	
PROJECT SPRINGFIELD-PLANT REPLACEMENT	
DRAWN BY R. THOMAS	CHECKED BY J. RITCHIE
DATE 05-SEP-24	REVISION 2.0
SHEET SIZE C	SHEET NO. 1 OF 1

24009 M-901

1

2

3

4

5

A

B

C

D

E

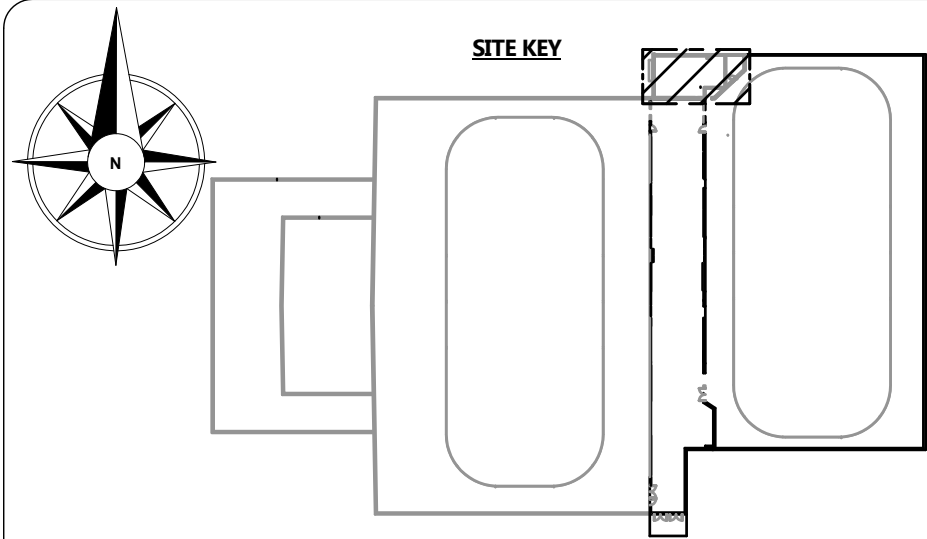

- NOTES:**
- ALL CONCRETE PADS SHOULD HAVE THICKNESS OF 4".
 - FOR EQUIPMENT LAYOUT AND DETAILS REFER TO 24009 M-401.
 - EXHAUST FANS AND LOUVER ARE HIDDEN FOR CLARITY.

NOTES

REFERENCE DEFINITION	
SHEET COLUMN	SHEET ROW
(#, X#)	

COPYRIGHT AND DISCLAIMER
 THIS WORK IS THE SOLE PROPERTY OF I.B. STOREY INC AND IS INTENDED SOLELY FOR THE INFORMATION OF THE CLIENT. ALL RIGHTS RESERVED. THE WORK MAY NOT BE REPRODUCED OR DISTRIBUTED, WHOLE OR IN PART, WITHOUT THE PRIOR WRITTEN PERMISSION OF I.B. STOREY INC.
 THIS DOCUMENT MAY NOT BE USED FOR ANY OTHER PROJECTS OR WITHOUT INVOLVEMENT OF I.B. STOREY INC. ANY USE WHICH A THIRD PARTY MAKES OF THE WORK, OR ANY RELIANCE ON OR DECISIONS TO BE MADE BASED ON IT, ARE THE RESPONSIBILITY OF SUCH THIRD PARTIES.

**- NOT FOR CONSTRUCTION -
 CONFIDENTIAL & PROPRIETARY**

1.0	ISSUED FOR DETAILED DESIGN	05-SEP-24	H.D.
VER #	REVISIONS	DATE	BY



CHARLOTTETOWN PE
 VAUGHAN ON
 REDINGTON SHORES FL
 PLANO, TX

WWW.IBSTOREY.COM

STAMP

DRAWING NUMBER	24009 MP403
DRAWING NAME	PLANT ROOM COOLING PIPING LARGE-SCALE VIEW
CLIENT	SPRINGFIELD PARK DISTRICT
PROJECT	SPRINGFIELD-PLANT REPLACEMENT
DRAWN BY	H.DHAMELIYA
CHECKED BY	J.RITCHIE
DATE	05-SEP-24
REVISION	1.0
SHEET SIZE	C
SHEET NO.	1 OF 2

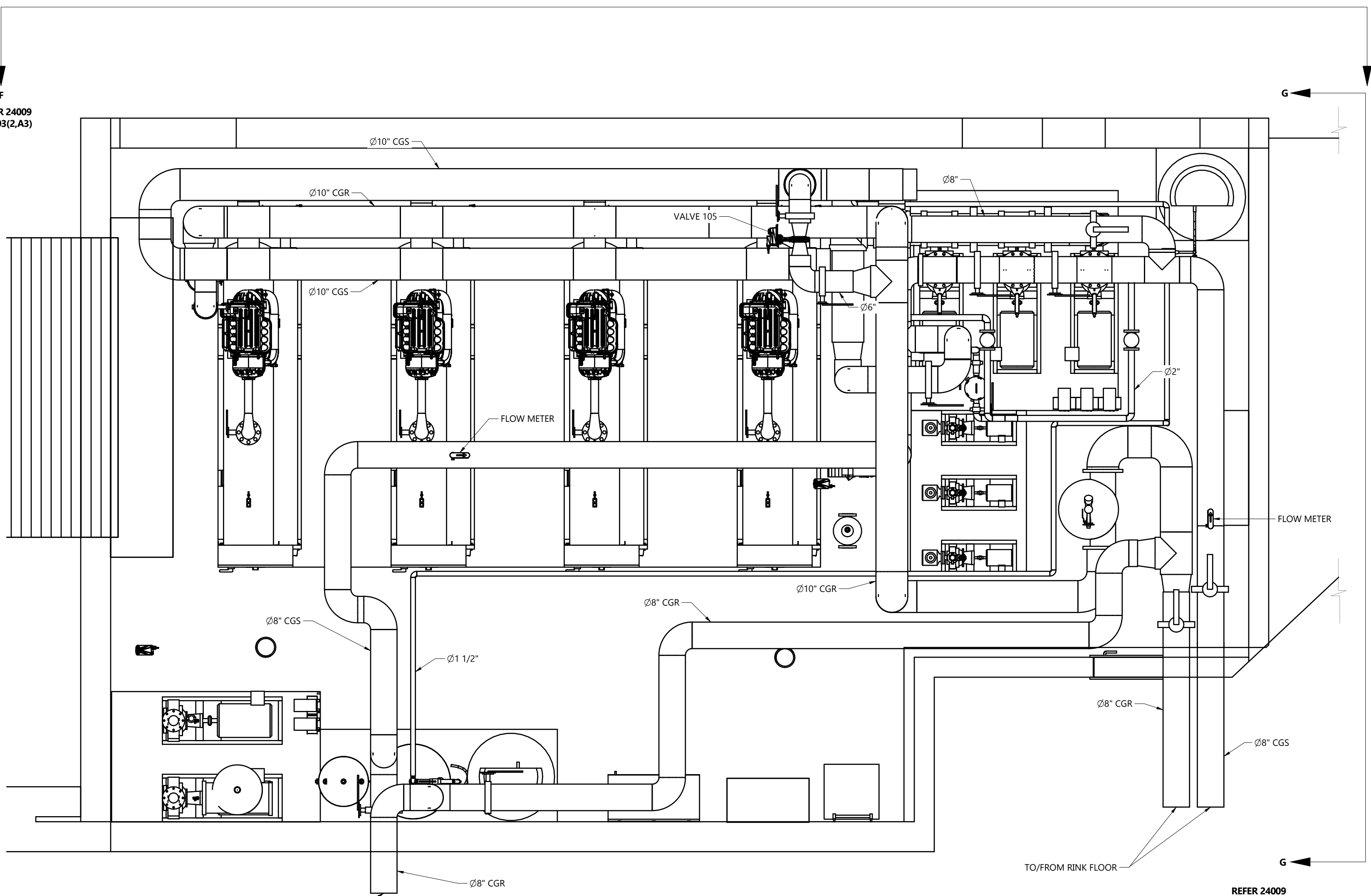

COOLING PIPING PLAN
 SCALE 3/8" = 1'-0"

COOLING PIPING PLAN

REFER 24009
 MP403(2,A5)

24009 MP403

1

2

3

4

5

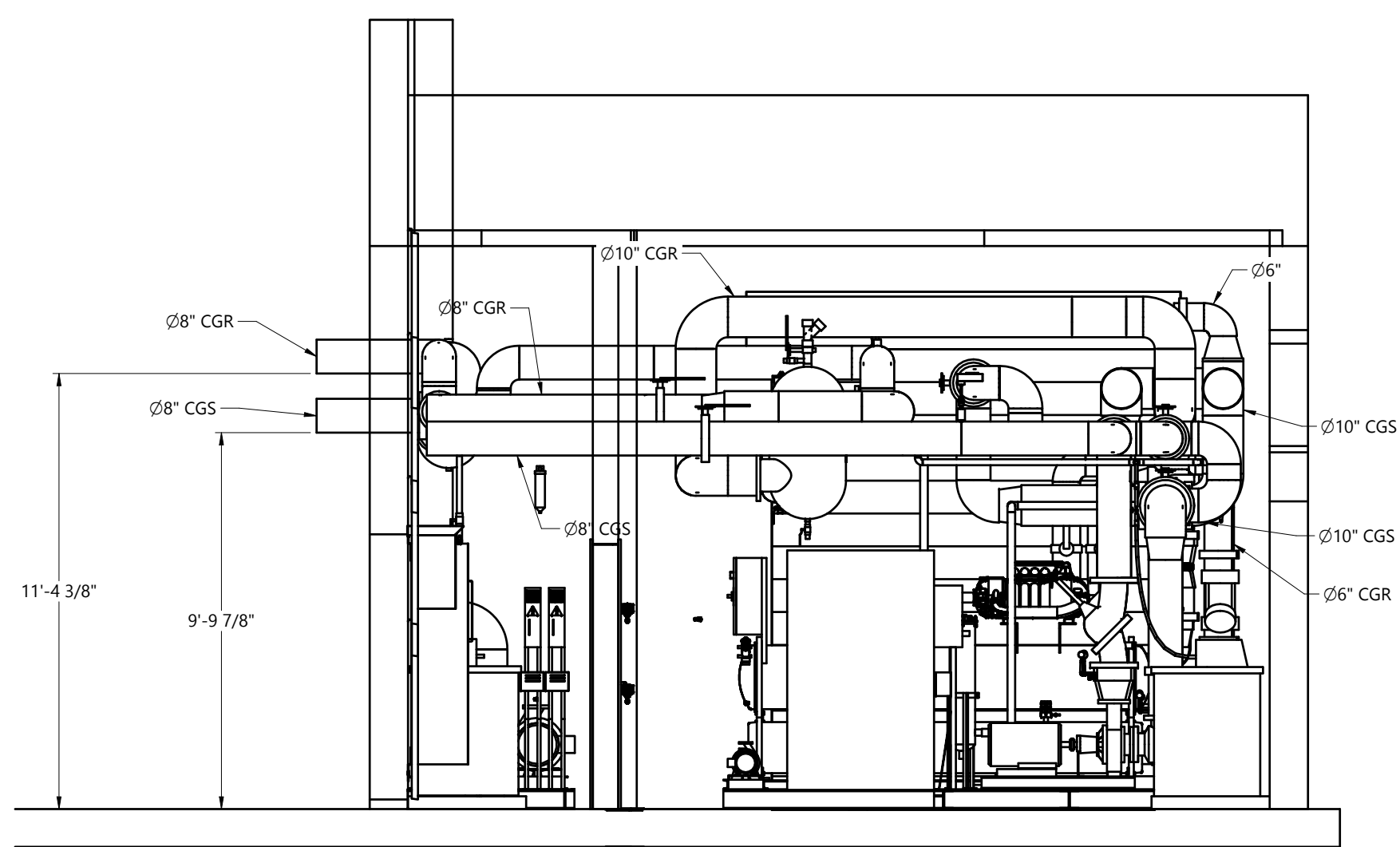
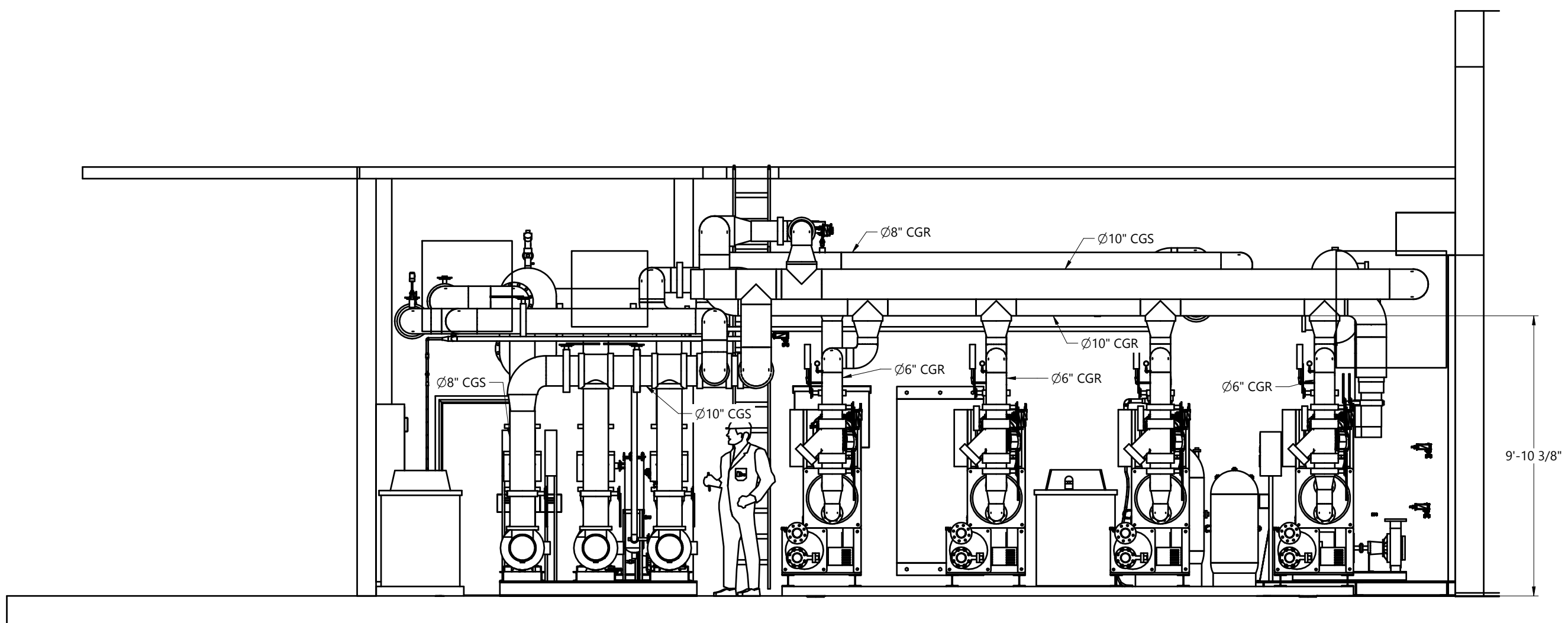

COOLING PIPING SECTION VIEWS

NOTES

REFERENCE DEFINITION

SHEET COLUMN	SHEET ROW
(#, X#)	

COPYRIGHT AND DISCLAIMER
THIS WORK IS THE SOLE PROPERTY OF I.B. STOREY INC AND IS INTENDED SOLELY FOR THE INFORMATION OF THE CLIENT. ALL RIGHTS RESERVED. THE WORK MAY NOT BE REPRODUCED OR DISTRIBUTED, WHOLE OR IN PART, WITHOUT THE PRIOR WRITTEN PERMISSION OF I.B. STOREY INC.
THIS DOCUMENT MAY NOT BE USED FOR ANY OTHER PROJECTS OR WITHOUT INVOLVEMENT OF I.B. STOREY INC. ANY USE WHICH A THIRD PARTY MAKES OF THE WORK, OR ANY RELIANCE ON OR DECISIONS TO BE MADE BASED ON IT, ARE THE RESPONSIBILITY OF SUCH THIRD PARTIES.

- NOT FOR CONSTRUCTION -
CONFIDENTIAL & PROPRIETARY

VER #	REVISIONS	DATE	BY
1.0	ISSUED FOR DETAILED DESIGN	05-SEP-24	H.D.

I.B. STOREY
Risk Engineering Experts

CHARLOTTETOWN PE
VAUGHAN ON
REDINGTON SHORES FL
PLANO, TX

WWW.IBSTOREY.COM

STAMP

DRAWING NUMBER 24009 MP403	
DRAWING NAME PLANT ROOM COOLING PIPING LARGE-SCALE VIEW	
CLIENT SPRINGFIELD PARK DISTRICT	
PROJECT SPRINGFIELD-PLANT REPLACEMENT	
DRAWN BY H.DHAMELIYA	CHECKED BY J.RITCHIE
DATE 05-SEP-24	REVISION 1.0
SHEET SIZE C	SHEET NO. 2 OF 2

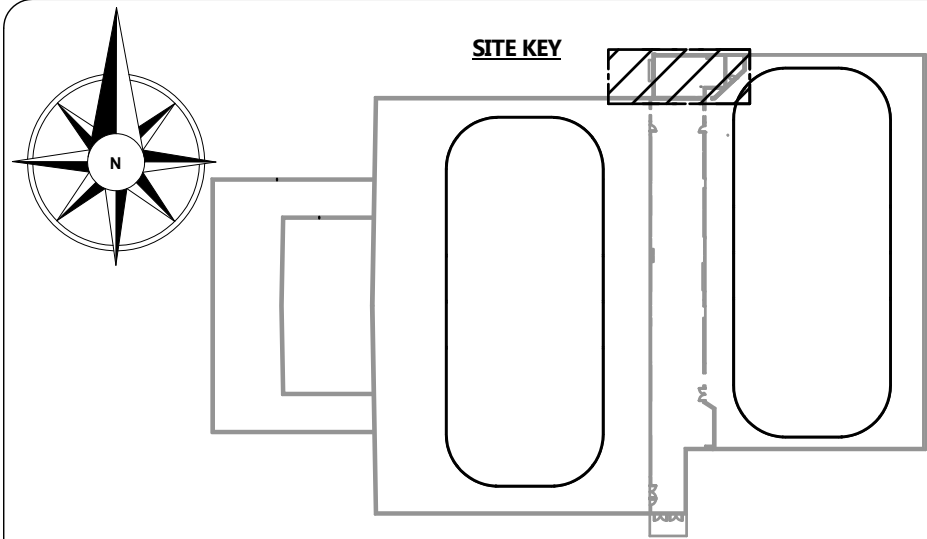

NOTES:

- ALL CONCRETE PADS SHOULD HAVE THICKNESS OF 4".
- FOR EQUIPMENT LAYOUT AND DETAILS REFER TO 24009 M-401.
- EXHAUST FANS AND LOUVER ARE HIDDEN FOR CLARITY.

NOTES

REFERENCE DEFINITION	
SHEET COLUMN	SHEET ROW
(#, X#)	

COPYRIGHT AND DISCLAIMER

THIS WORK IS THE SOLE PROPERTY OF I.B. STOREY INC AND IS INTENDED SOLELY FOR THE INFORMATION OF THE CLIENT. ALL RIGHTS RESERVED. THE WORK MAY NOT BE REPRODUCED OR DISTRIBUTED, WHOLE OR IN PART, WITHOUT THE PRIOR WRITTEN PERMISSION OF I.B. STOREY INC. THIS DOCUMENT MAY NOT BE USED FOR ANY OTHER PROJECTS OR WITHOUT INVOLVEMENT OF I.B. STOREY INC. ANY USE WHICH A THIRD PARTY MAKES OF THE WORK, OR ANY RELIANCE ON OR DECISIONS TO BE MADE BASED ON IT, ARE THE RESPONSIBILITY OF SUCH THIRD PARTIES.

- NOT FOR CONSTRUCTION -
CONFIDENTIAL & PROPRIETARY

VER #	REVISIONS	DATE	BY
1.0	ISSUED FOR DETAILED DESIGN	05-SEP-24	V.K.



CHARLOTTETOWN PE
VAUGHAN ON
REDINGTON SHORES FL
PLANO, TX

WWW.IBSTOREY.COM

STAMP

DRAWING NUMBER	
24009 MP405	
DRAWING NAME	
PLANT ROOM HEATING PIPING LARGE-SCALE VIEW	
CLIENT	
SPRINGFIELD PARK DISTRICT	
PROJECT	
SPRINGFIELD-PLANT REPLACEMENT	
DRAWN BY	CHECKED BY
V.KOFANOV	J.RITCHIE
DATE	REVISION
05-SEP-24	1.0
SHEET SIZE	SHEET NO.
C	1 OF 2

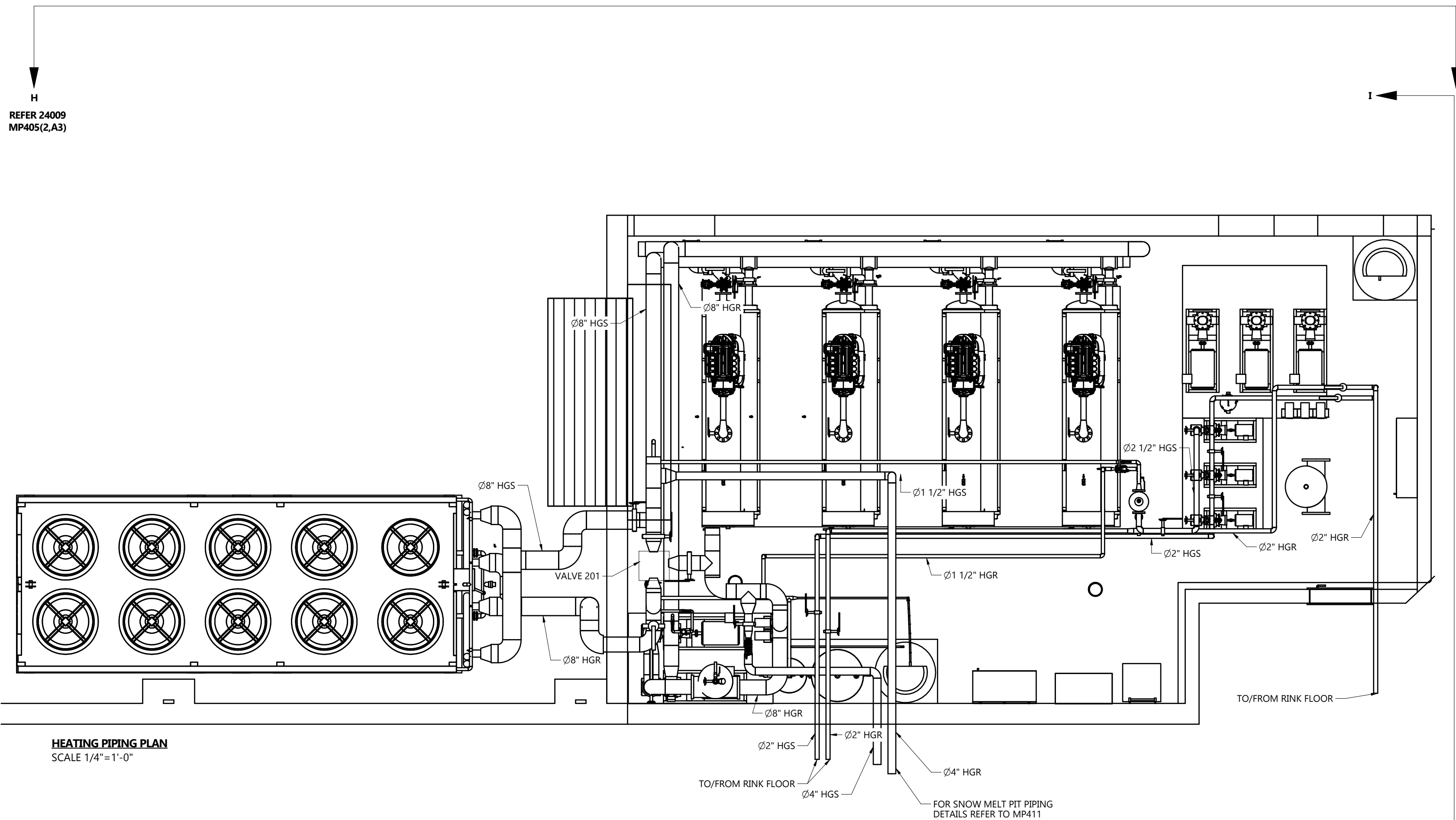

HEATING PIPING PLAN
SCALE 1/4" = 1'-0"

HEATING PIPING PLAN

REFER 24009
MP405(2,A5)

24009 MP405

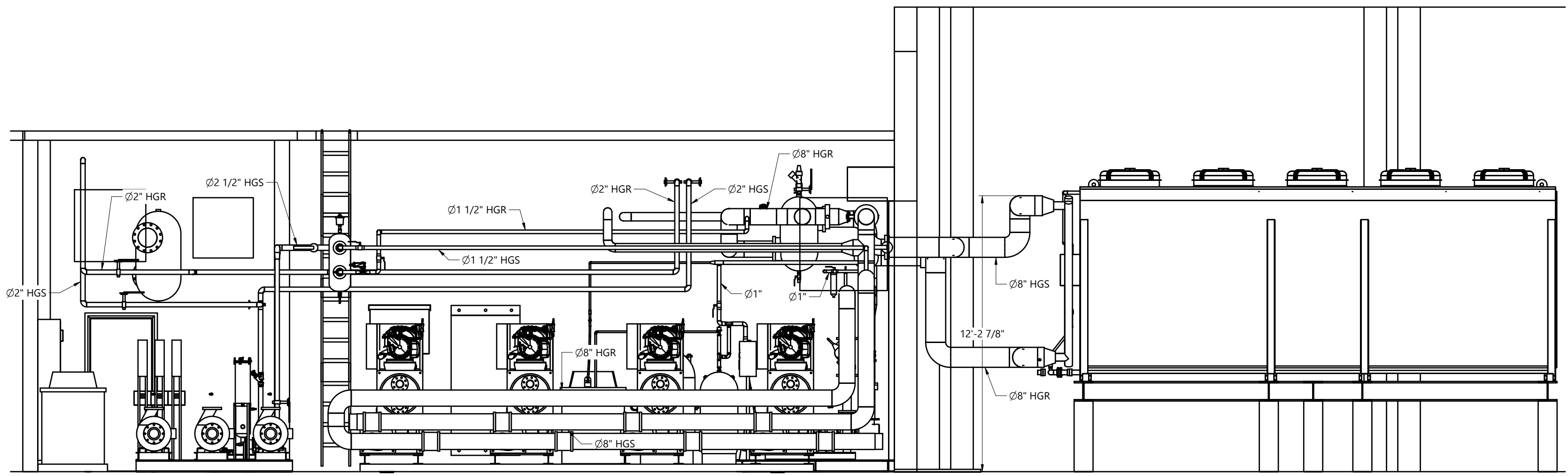

SECTION VIEW H-H (24009 MP405.1.A2)
SCALE 1/4"=1'-0"

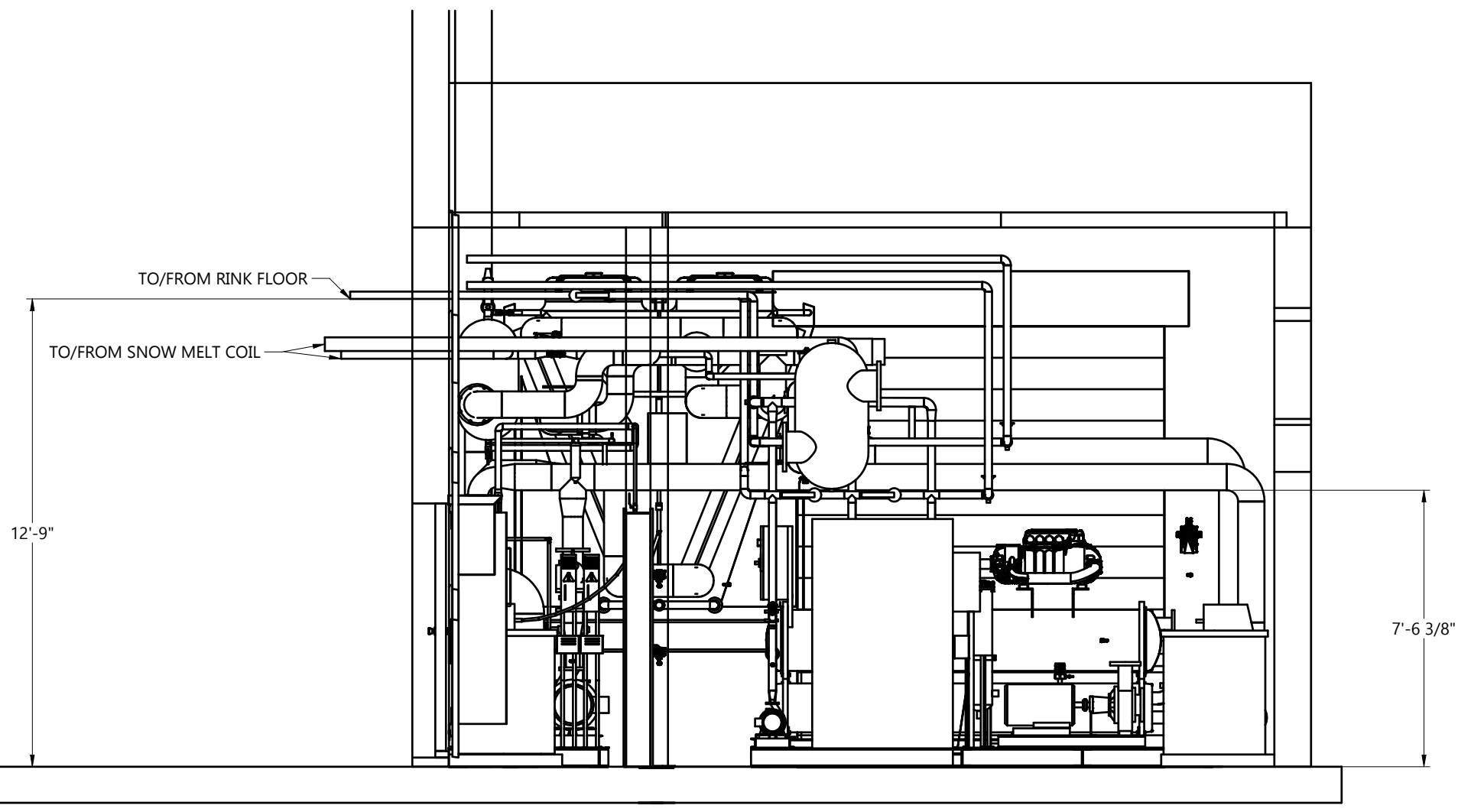

SECTION VIEW I-I (24009 MP405.1.D5)
SCALE 1/4"=1'-0"

HEATING PIPING SECTION VIEWS

NOTES

REFERENCE DEFINITION	
SHEET COLUMN	SHEET ROW
(#, X#)	

COPYRIGHT AND DISCLAIMER
THIS WORK IS THE SOLE PROPERTY OF I.B. STOREY INC AND IS INTENDED SOLELY FOR THE INFORMATION OF THE CLIENT. ALL RIGHTS RESERVED. THE WORK MAY NOT BE REPRODUCED OR DISTRIBUTED, WHOLE OR IN PART, WITHOUT THE PRIOR WRITTEN PERMISSION OF I.B. STOREY INC.
THIS DOCUMENT MAY NOT BE USED FOR ANY OTHER PROJECTS OR WITHOUT INVOLVEMENT OF I.B. STOREY INC. ANY USE WHICH A THIRD PARTY MAKES OF THE WORK, OR ANY RELIANCE ON OR DECISIONS TO BE MADE BASED ON IT, ARE THE RESPONSIBILITY OF SUCH THIRD PARTIES.

- NOT FOR CONSTRUCTION -
CONFIDENTIAL & PROPRIETARY

VER #	REVISIONS	DATE	BY
1.0	ISSUED FOR DETAILED DESIGN	05-SEP-24	V.K.

I.B. STOREY
Rink Engineering Experts

CHARLOTTETOWN PE
VAUGHAN ON
REDINGTON SHORES FL
PLANO, TX

WWW.IBSTOREY.COM

STAMP

DRAWING NUMBER		24009 MP405	
DRAWING NAME		PLANT ROOM HEATING PIPING LARGE-SCALE VIEW	
CLIENT		SPRINGFIELD PARK DISTRICT	
PROJECT		SPRINGFIELD-PLANT REPLACEMENT	
DRAWN BY	CHECKED BY		
V.KOFANOV	J.RITCHIE		
DATE	REVISION		
05-SEP-24	1.0		
SHEET SIZE	SHEET NO.		
C	2 OF 2		

24009 MP405

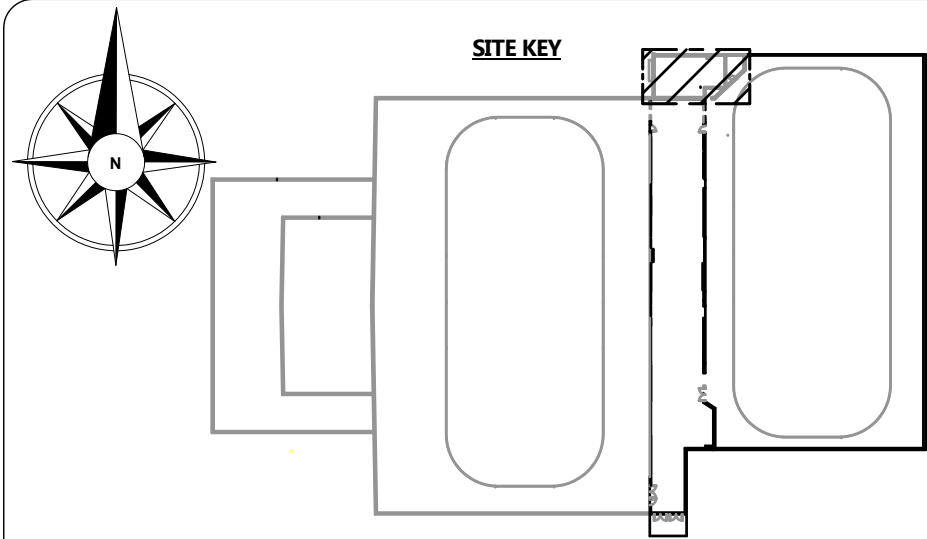

NOTES:

- ALL CONCRETE PADS SHOULD HAVE THICKNESS OF 4".
- FOR EQUIPMENT LAYOUT AND DETAILS REFER TO 24009 M-401.

NOTES

REFERENCE DEFINITION	
SHEET COLUMN	SHEET ROW
(#, X#)	

COPYRIGHT AND DISCLAIMER

THIS WORK IS THE SOLE PROPERTY OF I.B. STOREY INC AND IS INTENDED SOLELY FOR THE INFORMATION OF THE CLIENT. ALL RIGHTS RESERVED. THE WORK MAY NOT BE REPRODUCED OR DISTRIBUTED, WHOLE OR IN PART, WITHOUT THE PRIOR WRITTEN PERMISSION OF I.B. STOREY INC. THIS DOCUMENT MAY NOT BE USED FOR ANY OTHER PROJECTS OR WITHOUT INVOLVEMENT OF I.B. STOREY INC. ANY USE WHICH A THIRD PARTY MAKES OF THE WORK, OR ANY RELIANCE ON OR DECISIONS TO BE MADE BASED ON IT, ARE THE RESPONSIBILITY OF SUCH THIRD PARTIES.

- NOT FOR CONSTRUCTION -
CONFIDENTIAL & PROPRIETARY

VER #	REVISIONS	DATE	BY
1.0	ISSUED FOR DETAILED DESIGN	05-SEP-24	R.T.



CHARLOTTETOWN PE
VAUGHAN ON
REDINGTON SHORES FL
PLANO, TX

WWW.IBSTOREY.COM

DRAWING NUMBER	
24009 MP407	
DRAWING NAME	
PLANT ROOM RELIEF PIPING LARGE-SCALE VIEW	
CLIENT	
SPRINGFIELD PARK DISTRICT	
PROJECT	
SPRINGFIELD-PLANT REPLACEMENT	
DRAWN BY	CHECKED BY
R.THOMAS	J.RITCHIE
DATE	REVISION
05-SEP-24	1.0
SHEET SIZE	SHEET NO.
C	1 OF 2

REFER 24009
MP409(2,A3)

REFER 24009
MP409(2,A3)

RELIEF PIPING PLAN
SCALE 3/8"=1'-0"

RELIEF PIPING PLAN

24009 MP407

1

2

3

4

5

NOTES

REFERENCE DEFINITION	
SHEET COLUMN	SHEET ROW
SHEET NUMBER	(#, X#)

COPYRIGHT AND DISCLAIMER
 THIS WORK IS THE SOLE PROPERTY OF I.B. STOREY INC AND IS INTENDED SOLELY FOR THE INFORMATION OF THE CLIENT. ALL RIGHTS RESERVED. THE WORK MAY NOT BE REPRODUCED OR DISTRIBUTED, WHOLE OR IN PART, WITHOUT THE PRIOR WRITTEN PERMISSION OF I.B. STOREY INC.
 THIS DOCUMENT MAY NOT BE USED FOR ANY OTHER PROJECTS OR WITHOUT INVOLVEMENT OF I.B. STOREY INC. ANY USE WHICH A THIRD PARTY MAKES OF THE WORK, OR ANY RELIANCE ON OR DECISIONS TO BE MADE BASED ON IT, ARE THE RESPONSIBILITY OF SUCH THIRD PARTIES.

- NOT FOR CONSTRUCTION -
 CONFIDENTIAL & PROPRIETARY

THE DISCHARGE TO ATMOSPHERE SHALL BE NOT LESS THAN 15 FT. ABOVE THE ADJOINING GROUND LEVEL, AND NOT LESS THAN 20 FT. FROM ANY WINDOW, VENTILATION OPENING PEDESTRIAN WALKWAY, OR EXIT.

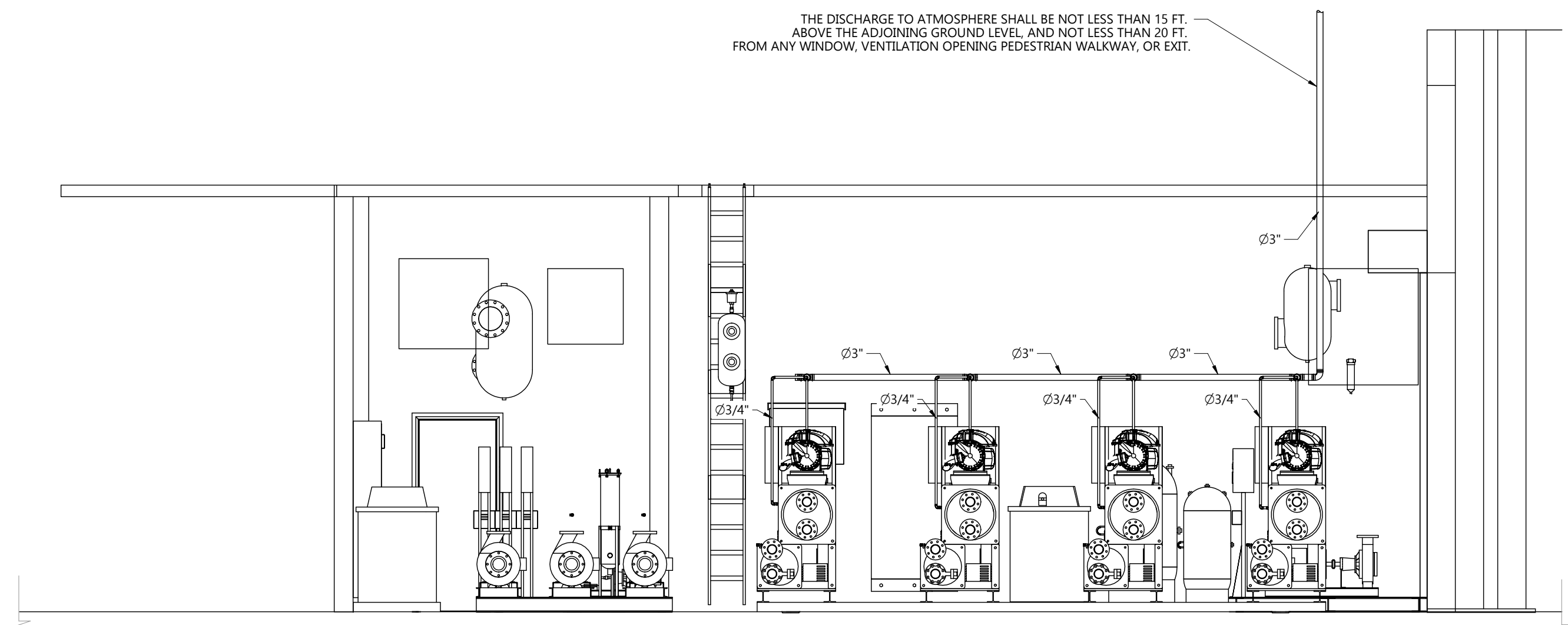

SECTION VIEW J-J (24009 MP409.1.A2)
 SCALE 1/4"=1'-0"

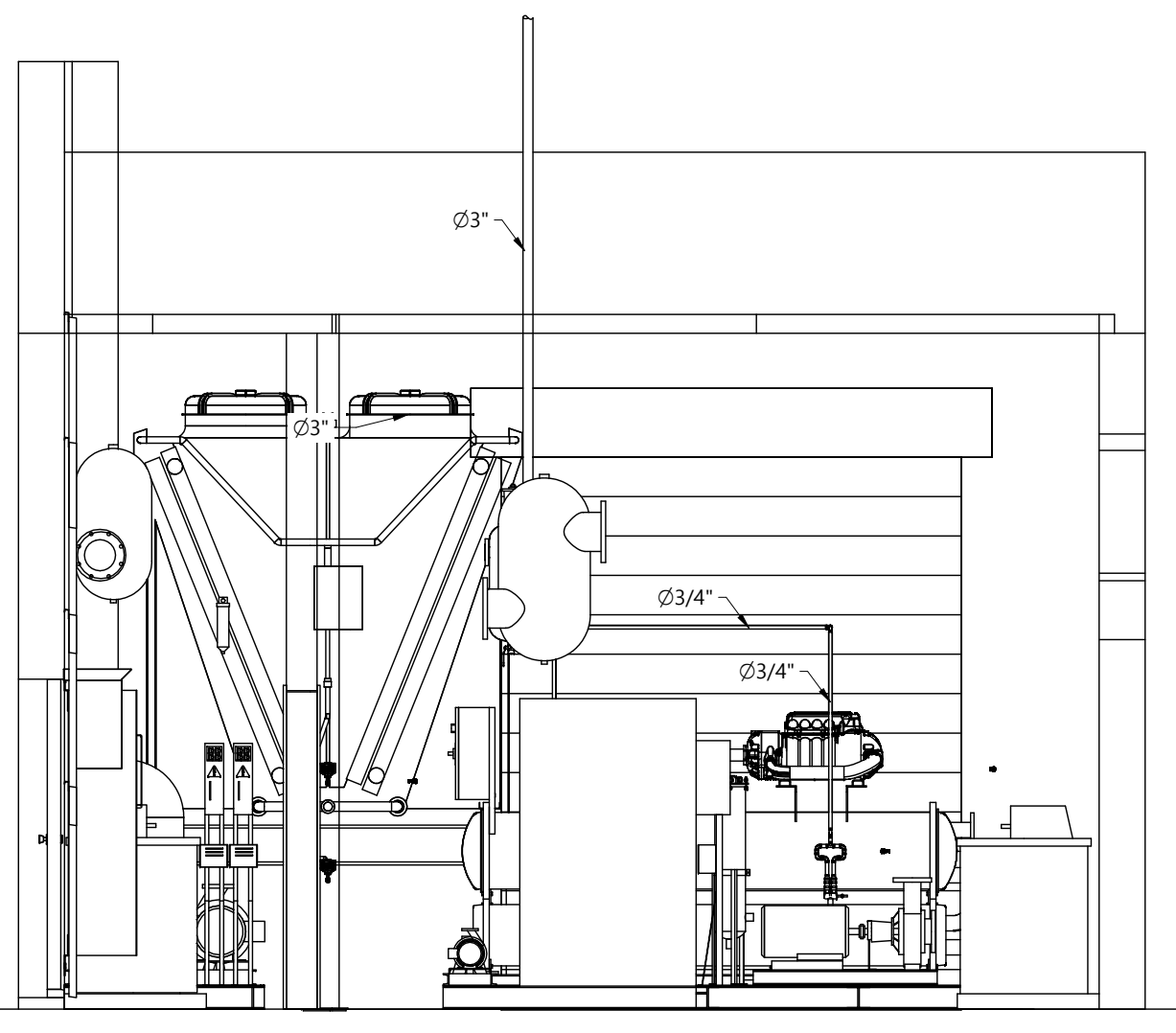

SECTION VIEW K-K (24009 MP409.1.D5)
 SCALE 1/4"=1'-0" RELIEF PIPING SECTION VIEWS

VER #	REVISIONS	DATE	BY
1.0	ISSUED FOR DETAILED DESIGN	05-SEP-24	R.T.

I.B. STOREY
 Risk Engineering Experts

CHARLOTTETOWN PE
 VAUGHAN ON
 REDINGTON SHORES FL
 PLANO, TX

WWW.IBSTOREY.COM

STAMP

DRAWING NUMBER	
24009 MP407	
DRAWING NAME	
PLANT ROOM RELIEF PIPING LARGE-SCALE VIEW	
CLIENT	
SPRINGFIELD PARK DISTRICT	
PROJECT	
SPRINGFIELD-PLANT REPLACEMENT	
DRAWN BY	CHECKED BY
R.THOMAS	J.RITCHIE
DATE	REVISION
05-SEP-24	1.0
SHEET SIZE	SHEET NO.
C	2 OF 2

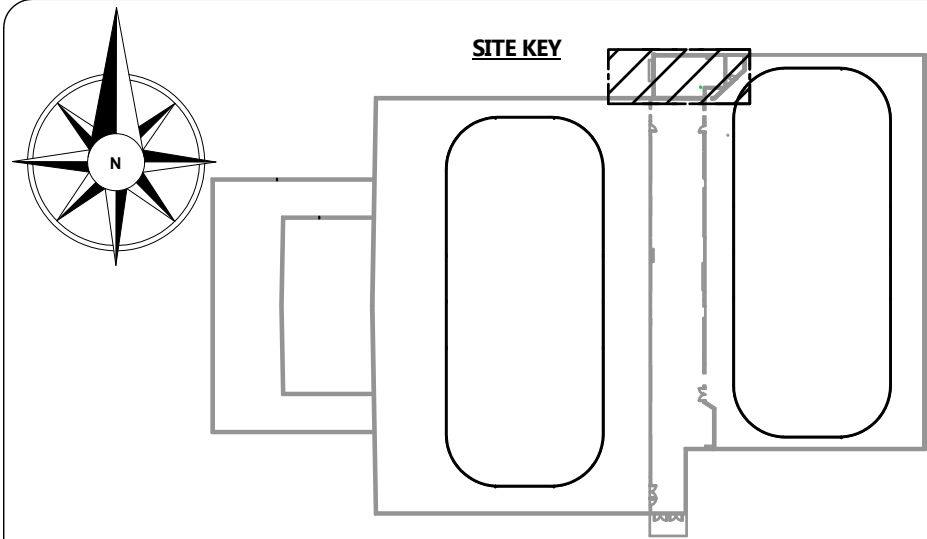

NOTES:

- ALL CONCRETE PADS SHOULD HAVE THICKNESS OF 4".
- FOR EQUIPMENT LAYOUT AND DETAILS REFER TO 24009 M-401.
- EXHAUST FANS AND LOUVER ARE HIDDEN FOR CLARITY.

NOTES

REFERENCE DEFINITION	
SHEET COLUMN	SHEET ROW
(#, X#)	

COPYRIGHT AND DISCLAIMER

THIS WORK IS THE SOLE PROPERTY OF I.B. STOREY INC AND IS INTENDED SOLELY FOR THE INFORMATION OF THE CLIENT. ALL RIGHTS RESERVED. THE WORK MAY NOT BE REPRODUCED OR DISTRIBUTED, WHOLE OR IN PART, WITHOUT THE PRIOR WRITTEN PERMISSION OF I.B. STOREY INC. THIS DOCUMENT MAY NOT BE USED FOR ANY OTHER PROJECTS OR WITHOUT INVOLVEMENT OF I.B. STOREY INC. ANY USE WHICH A THIRD PARTY MAKES OF THE WORK, OR ANY RELIANCE ON OR DECISIONS TO BE MADE BASED ON IT, ARE THE RESPONSIBILITY OF SUCH THIRD PARTIES.

- NOT FOR CONSTRUCTION -
CONFIDENTIAL & PROPRIETARY

VER #	REVISIONS	DATE	BY
1.0	ISSUED FOR DETAILED DESIGN	05-SEP-24	H.D.



CHARLOTTETOWN PE
VAUGHAN ON
REDINGTON SHORES FL
PLANO, TX

WWW.IBSTOREY.COM

STAMP

DRAWING NUMBER 24009 MP409	
DRAWING NAME PLANT ROOM WATER PIPING LARGE-SCALE VIEW	
CLIENT SPRINGFIELD PARK DISTRICT	
PROJECT SPRINGFIELD-PLANT REPLACEMENT	
DRAWN BY H.DHAMELIYA	CHECKED BY J.RITCHIE
DATE 05-SEP-24	REVISION 1.0
SHEET SIZE C	SHEET NO. 1 OF 2

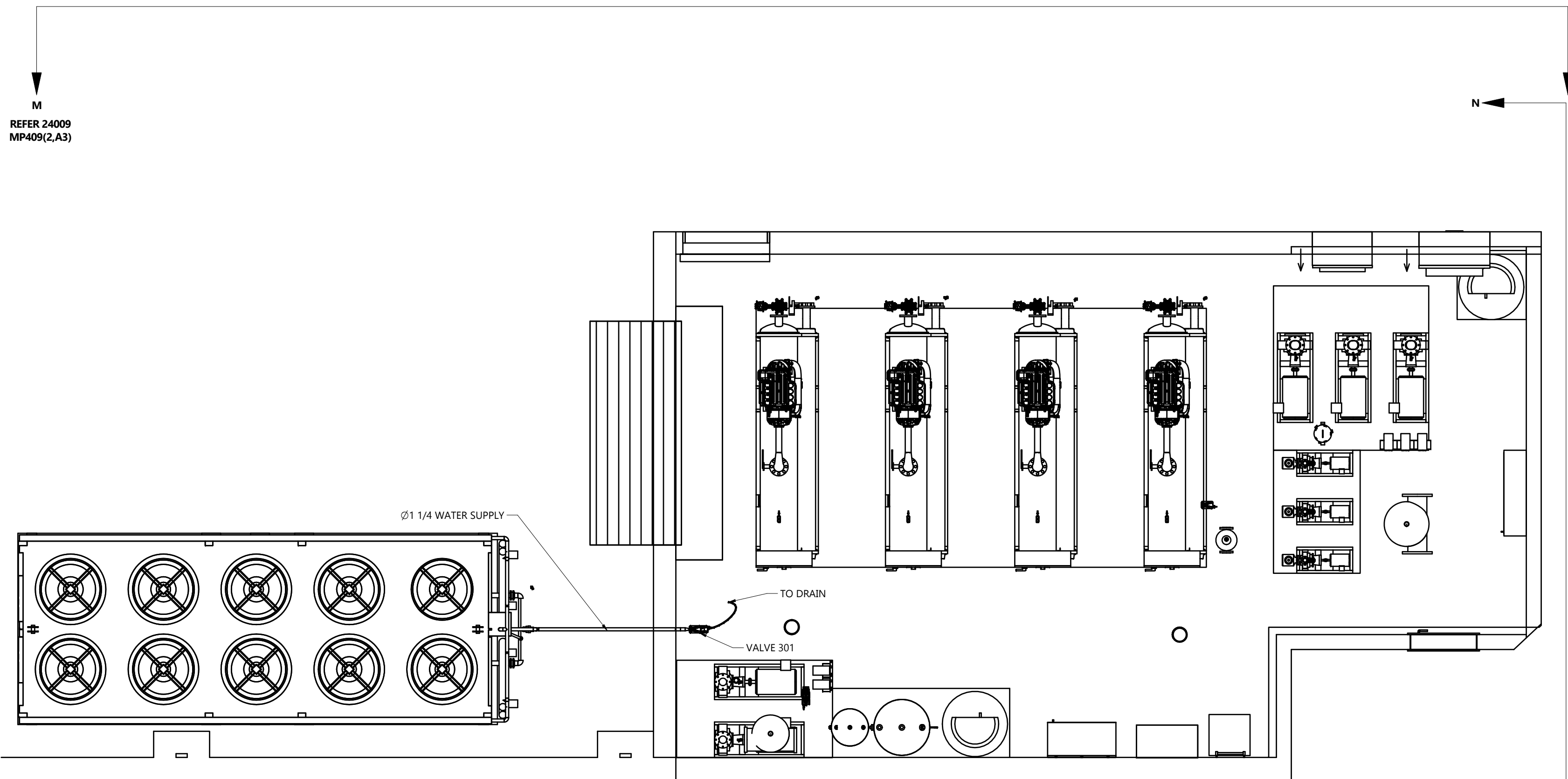

HEATING PIPING PLAN
SCALE 1/4" = 1'-0"

WATER PIPING PLAN

REFER 24009
MP409(2,A5)

24009 MP409

NOTES

REFERENCE DEFINITION	
SHEET COLUMN	SHEET ROW
SHEET NUMBER	(#, X#)

COPYRIGHT AND DISCLAIMER
 THIS WORK IS THE SOLE PROPERTY OF I.B. STOREY INC AND IS INTENDED SOLELY FOR THE INFORMATION OF THE CLIENT. ALL RIGHTS RESERVED. THE WORK MAY NOT BE REPRODUCED OR DISTRIBUTED, WHOLE OR IN PART, WITHOUT THE PRIOR WRITTEN PERMISSION OF I.B. STOREY INC.
 THIS DOCUMENT MAY NOT BE USED FOR ANY OTHER PROJECTS OR WITHOUT INVOLVEMENT OF I.B. STOREY INC. ANY USE WHICH A THIRD PARTY MAKES OF THE WORK, OR ANY RELIANCE ON OR DECISIONS TO BE MADE BASED ON IT, ARE THE RESPONSIBILITY OF SUCH THIRD PARTIES.

- NOT FOR CONSTRUCTION -
 CONFIDENTIAL & PROPRIETARY

VER #	REVISIONS	DATE	BY
1.0	ISSUED FOR DETAILED DESIGN	05-SEP-24	H.D.



CHARLOTTETOWN PE
 VAUGHAN ON
 REDINGTON SHORES FL
 PLANO, TX
 WWW.IBSTOREY.COM

STAMP

DRAWING NUMBER		24009 MP409
DRAWING NAME		PLANT ROOM WATER PIPING LARGE-SCALE VIEW
CLIENT		SPRINGFIELD PARK DISTRICT
PROJECT		SPRINGFIELD-PLANT REPLACEMENT
DRAWN BY	CHECKED BY	
H.DHAMELIYA	J.RITCHIE	
DATE	REVISION	
05-SEP-24	1.0	
SHEET SIZE	SHEET NO.	
C	2 OF 2	

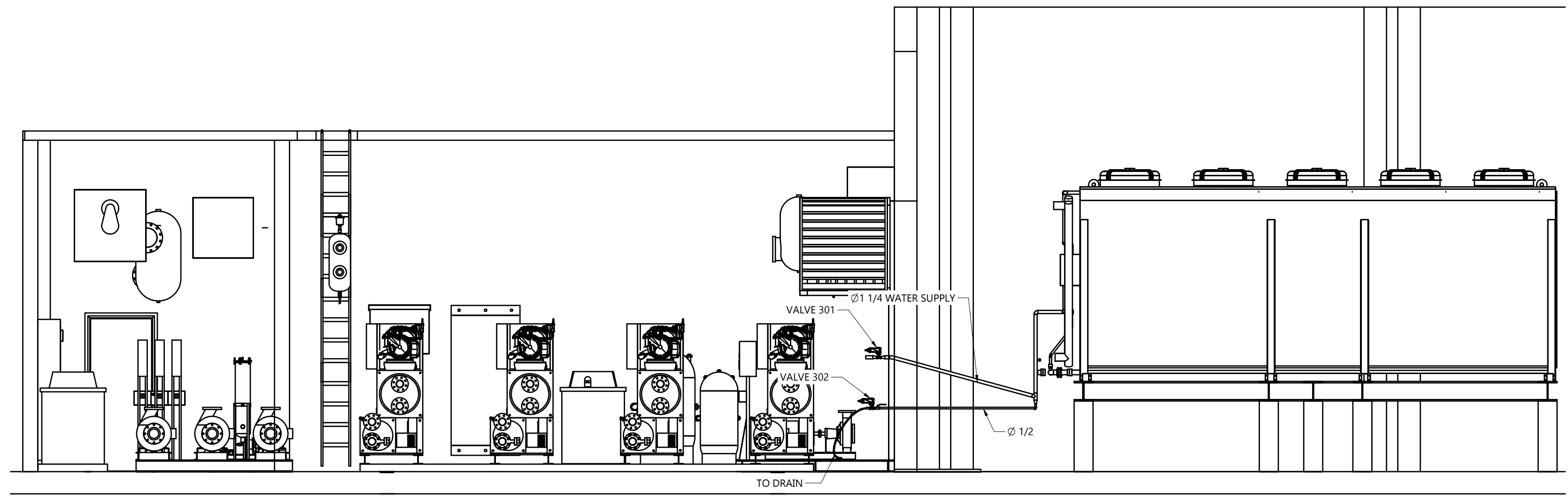

SECTION VIEW M-M (24009 MP409, 1,A2)
 SCALE 1/4"=1'-0"

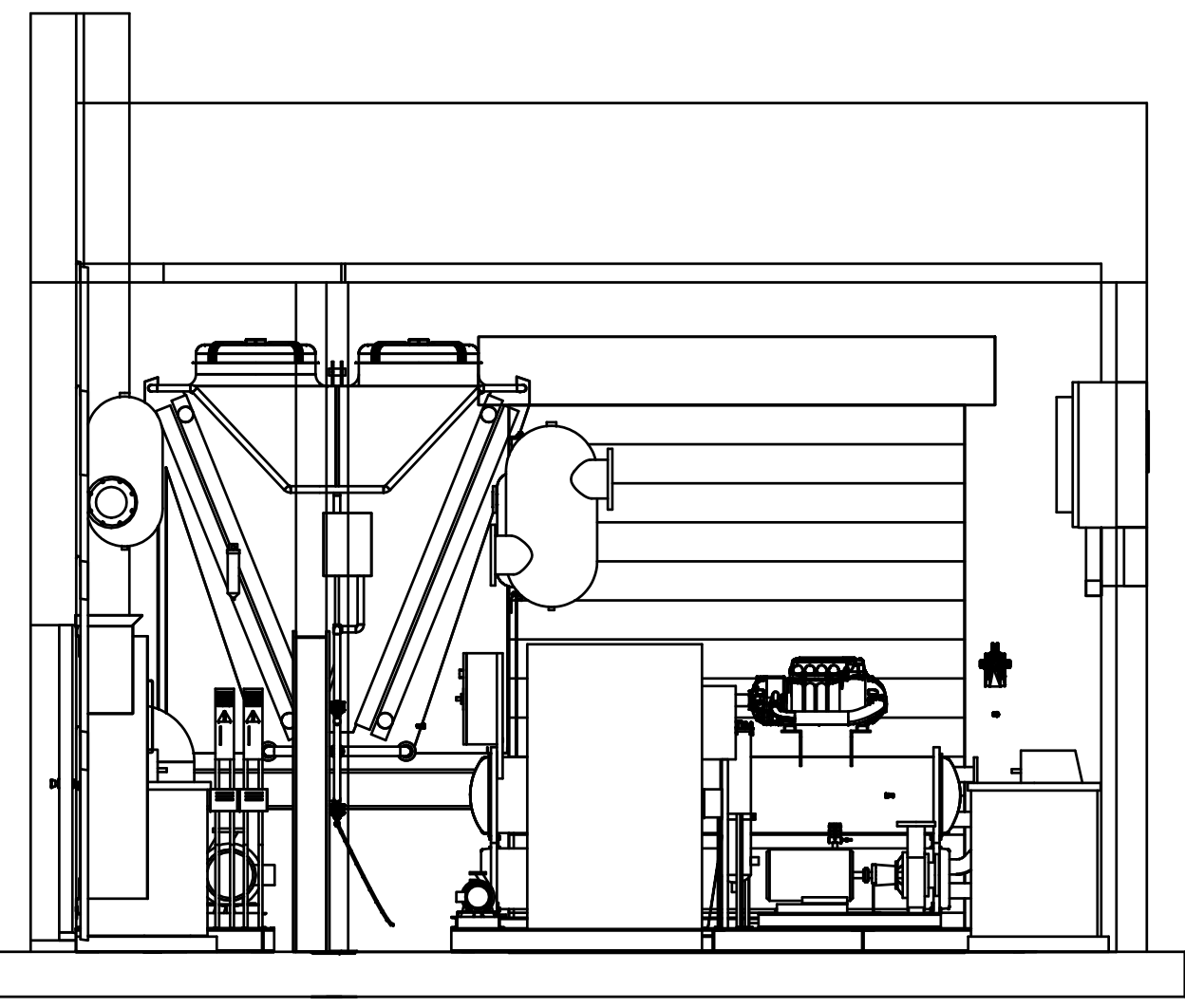

SECTION VIEW N-N (24009 MP409, 1,D5)
 SCALE 1/4"=1'-0"

WATER PIPING SECTION VIEWS

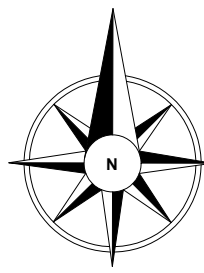

SITE KEY

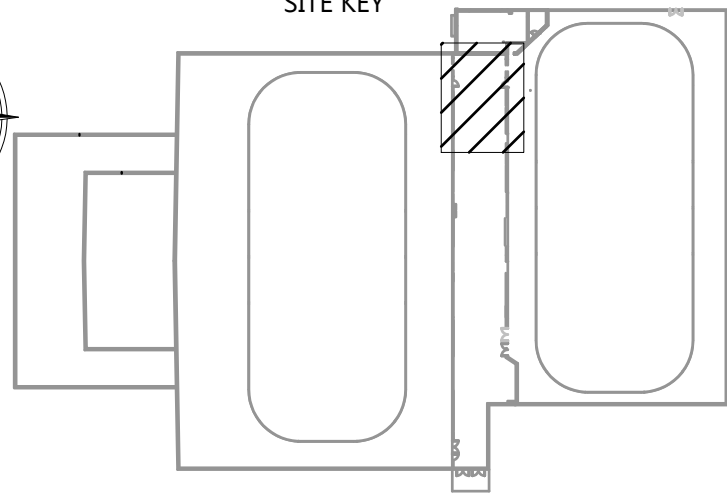

NOTE:
 • CONTRACTOR TO TEST EXISTING SNOW MELT PIT COIL FOR ANY LEAKS

NOTES

---	NEW
---	EXISTING

REFERENCE DEFINITION	
SHEET COLUMN	SHEET ROW
SHEET NUMBER	(#, X#)

COPYRIGHT AND DISCLAIMER
 THIS WORK IS THE SOLE PROPERTY OF I.B. STOREY INC AND IS INTENDED SOLELY FOR THE INFORMATION OF THE CLIENT. ALL RIGHTS RESERVED. THE WORK MAY NOT BE REPRODUCED OR DISTRIBUTED, WHOLE OR IN PART, WITHOUT THE PRIOR WRITTEN PERMISSION OF I.B. STOREY INC.
 THIS DOCUMENT MAY NOT BE USED FOR ANY OTHER PROJECTS OR WITHOUT INVOLVEMENT OF I.B. STOREY INC. ANY USE WHICH A THIRD PARTY MAKES OF THE WORK, OR ANY RELIANCE ON OR DECISIONS TO BE MADE BASED ON IT, ARE THE RESPONSIBILITY OF SUCH THIRD PARTIES.

- NOT FOR CONSTRUCTION -
 CONFIDENTIAL & PROPRIETARY

1.0	ISSUED FOR DETAILED DESIGN	05-SEP-24	H.A.
VER #	REVISIONS	DATE	BY



CHARLOTTETOWN PE
 VAUGHAN ON
 REDINGTON SHORES FL
 PLANO TX

WWW.IBSTOREY.COM

STAMP	
DRAWING NUMBER	24009 MP411
DRAWING NAME	SNOW MELT PIT PIPING LARGE-SCALE VIEW
CLIENT	SPRINGFIELD PARK DISTRICT
PROJECT	SPRINGFIELD - PLANT REPLACEMENT
DRAWN BY	CHECKED BY
H.AKAR	J. RITCHIE
DATE	REVISION
05-SEP-24	1.0
SHEET SIZE	SHEET NO.
C	1 OF 1

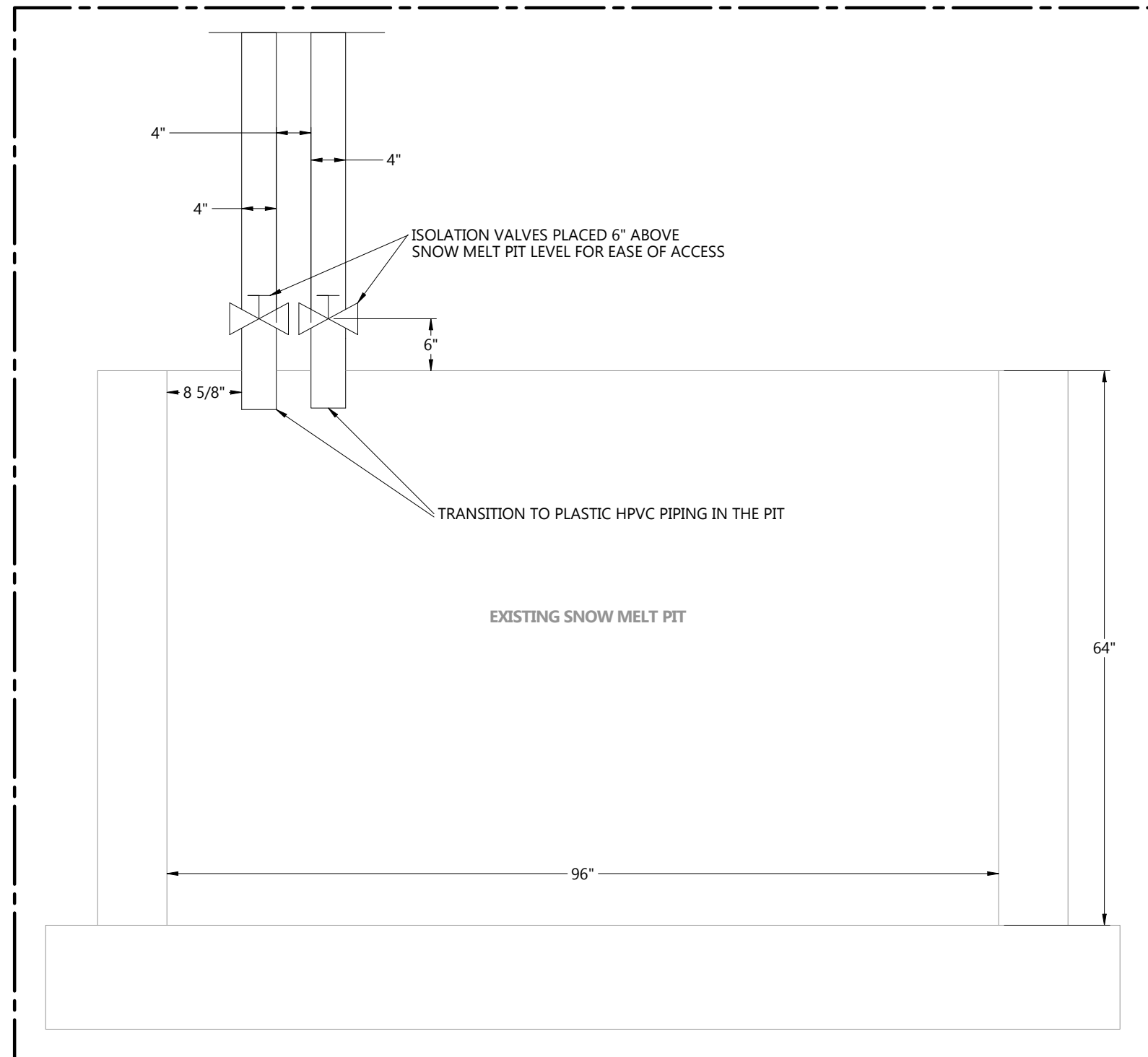

SECTION CUT L-L (1, D4): SNOW MELT PIT PIPING
 SCALE 3/4"=1'

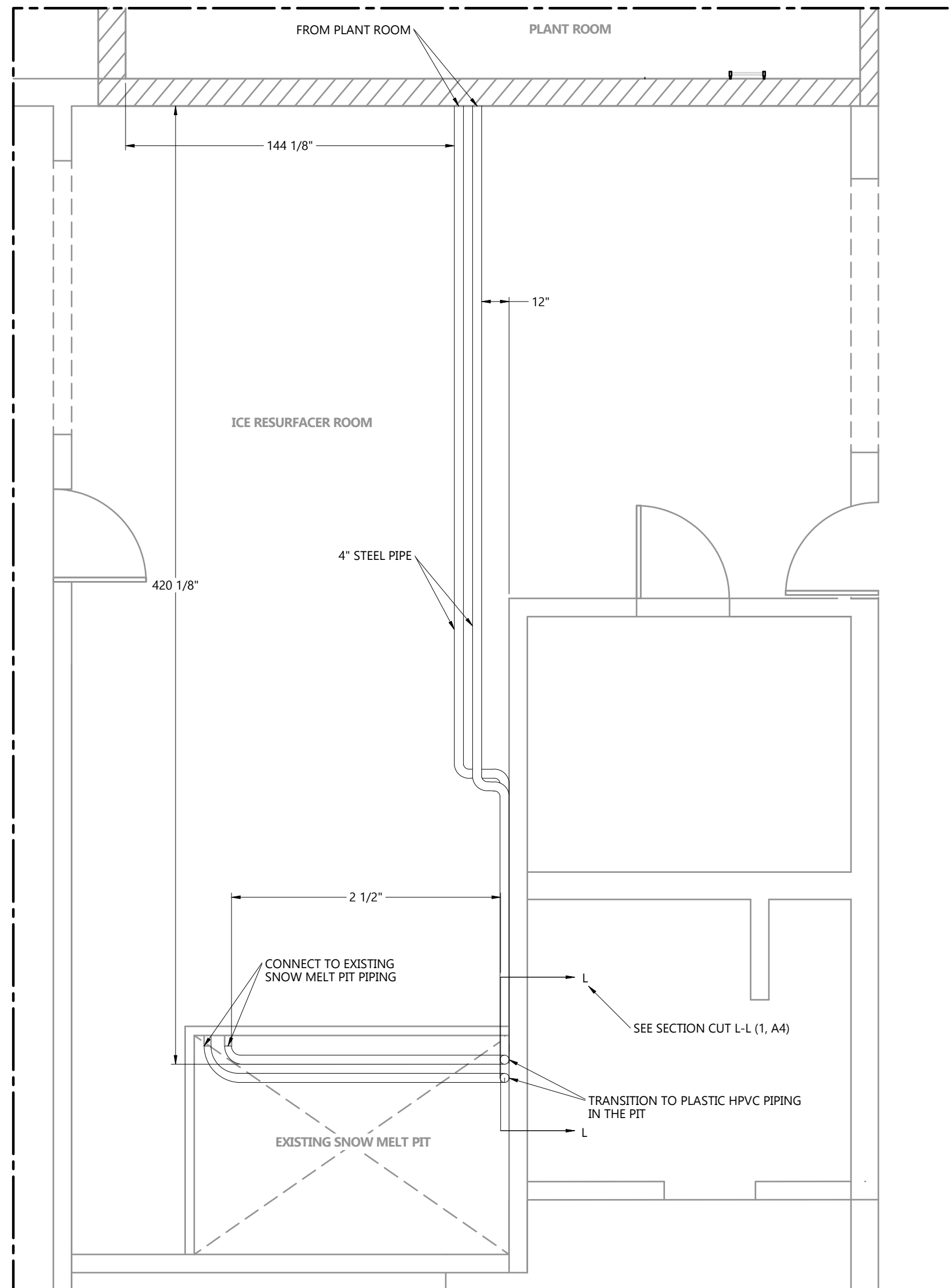

SNOW MELT PIT PIPING ENLARGED VIEW
 SCALE 1"=4'

SNOW MELT PIT PIPING ENLARGED VIEW

24009 MP411

1

2

3

4

5

A

B

C

D

E

A

B

C

D

E

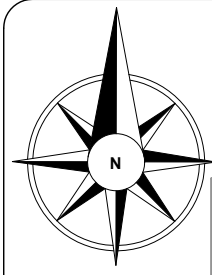

SITE KEY

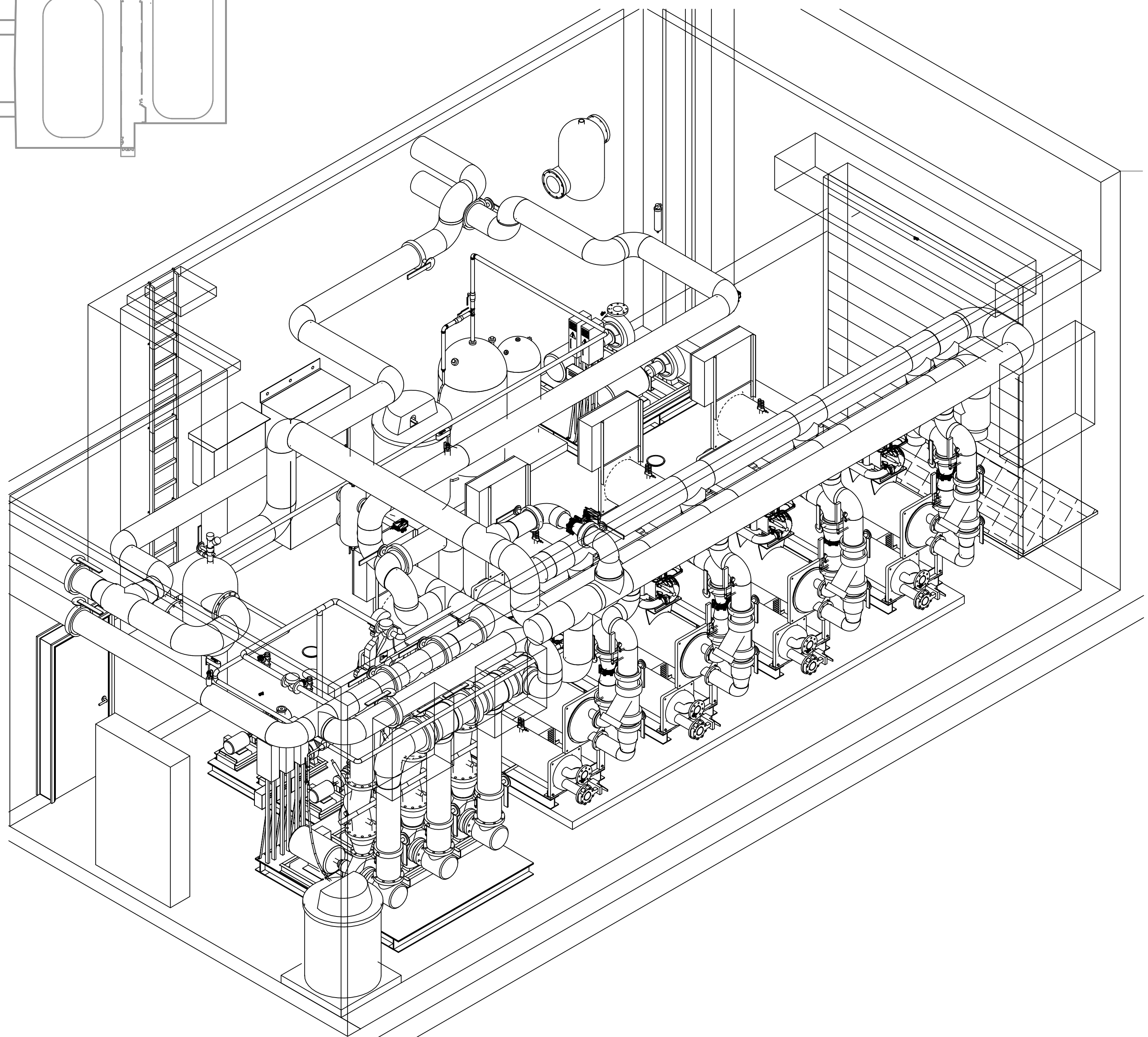
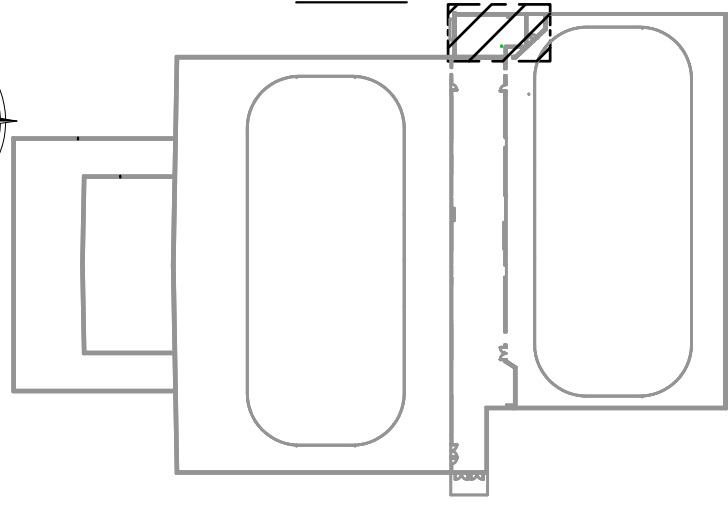

ISOMETRIC VIEW
SCALE 3/8"=1'-0"
COOLING PIPING ISOMETRIC VIEW

NOTES:

- AFC HIDDEN FOR CLARITY
- ALL EXHAUST FANS AND INTAKE LOUVERS ARE HIDDEN FOR CLARITY

NOTES

—	NEW
—	EXISTING

REFERENCE DEFINITION	
SHEET COLUMN	SHEET ROW
SHEET NUMBER	(#, X#)

COPYRIGHT AND DISCLAIMER
THIS WORK IS THE SOLE PROPERTY OF I.B. STOREY INC AND IS INTENDED SOLELY FOR THE INFORMATION OF THE CLIENT. ALL RIGHTS RESERVED. THE WORK MAY NOT BE REPRODUCED OR DISTRIBUTED, WHOLE OR IN PART, WITHOUT THE PRIOR WRITTEN PERMISSION OF I.B. STOREY INC.
THIS DOCUMENT MAY NOT BE USED FOR ANY OTHER PROJECTS OR WITHOUT INVOLVEMENT OF I.B. STOREY INC. ANY USE WHICH A THIRD PARTY MAKES OF THE WORK, OR ANY RELIANCE ON OR DECISIONS TO BE MADE BASED ON IT, ARE THE RESPONSIBILITY OF SUCH THIRD PARTIES.

- NOT FOR CONSTRUCTION -
CONFIDENTIAL & PROPRIETARY

1.0	ISSUED FOR DETAILED DESIGN	05-SEPT-24	H.D.
VER #	REVISIONS	DATE	BY



CHARLOTTETOWN PE
VAUGHAN ON
REDINGTON SHORES FL
PLANO, TX

WWW.IBSTOREY.COM

STAMP

DRAWING NUMBER	
24009 MP903	
DRAWING NAME	
COOLING PIPING ISOMETRIC VIEW	
CLIENT	
SPRINGFIELD PARK DISTRICT	
PROJECT	
SPRINGFIELD-PLANT REPLACEMENT	
DRAWN BY	CHECKED BY
H.DHAMELIYA	J.RITCHIE
DATE	REVISION
05-SEP-24	1.0
SHEET SIZE	SHEET NO.
C	1 OF 1

24009 MP903

1

2

3

4

5

4

4

5

5

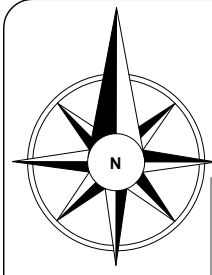

SITE KEY

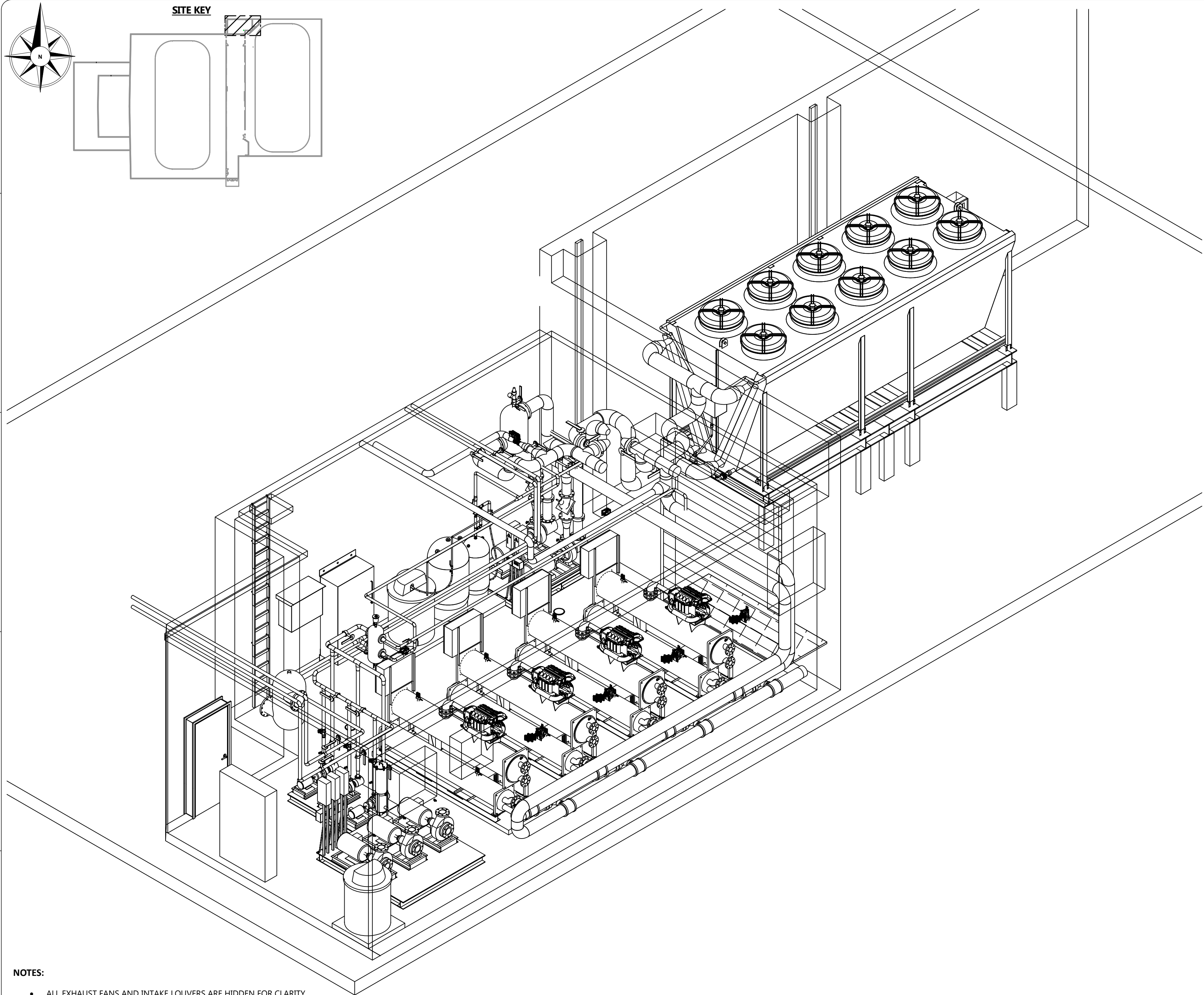
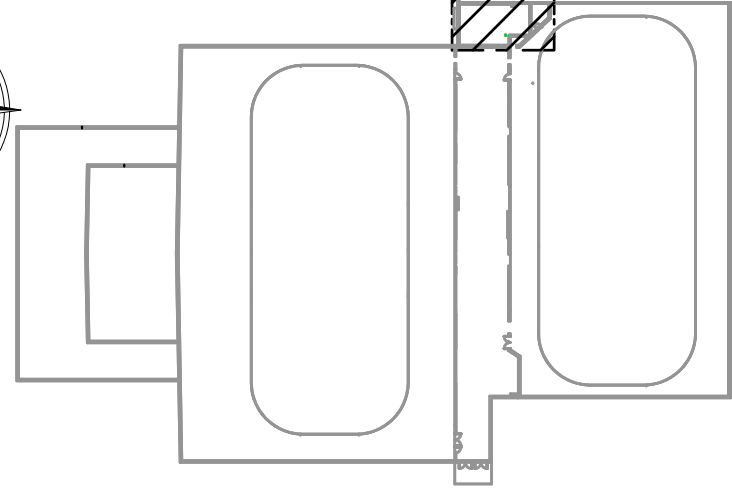

ISOMETRIC VIEW
SCALE 1/4" = 1'-0"

HEATING PIPING ISOMETRIC VIEW

NOTES:

- ALL EXHAUST FANS AND INTAKE LOUVERS ARE HIDDEN FOR CLARITY

NOTES

REFERENCE DEFINITION	
SHEET COLUMN	SHEET ROW
SHEET NUMBER	(#, X#)

COPYRIGHT AND DISCLAIMER
 THIS WORK IS THE SOLE PROPERTY OF I.B. STOREY INC AND IS INTENDED SOLELY FOR THE INFORMATION OF THE CLIENT. ALL RIGHTS RESERVED. THE WORK MAY NOT BE REPRODUCED OR DISTRIBUTED, WHOLE OR IN PART, WITHOUT THE PRIOR WRITTEN PERMISSION OF I.B. STOREY INC.
 THIS DOCUMENT MAY NOT BE USED FOR ANY OTHER PROJECTS OR WITHOUT INVOLVEMENT OF I.B. STOREY INC. ANY USE WHICH A THIRD PARTY MAKES OF THE WORK, OR ANY RELIANCE ON OR DECISIONS TO BE MADE BASED ON IT, ARE THE RESPONSIBILITY OF SUCH THIRD PARTIES.

- NOT FOR CONSTRUCTION -
 CONFIDENTIAL & PROPRIETARY

VER #	REVISIONS	DATE	BY
2.0	ISSUED FOR DETAILED DESIGN	05-SEPT-24	H.D.
1.0	ISSUED FOR SCHEMATIC DESIGN	28-JUN-24	H.D.



CHARLOTTETOWN PE
 VAUGHAN ON
 REDINGTON SHORES FL
 PLANO, TX

WWW.IBSTOREY.COM

STAMP

DRAWING NUMBER		24009 MP905	
DRAWING NAME		HEATING PIPING ISOMETRIC VIEW	
CLIENT		SPRINGFIELD PARK DISTRICT	
PROJECT		SPRINGFIELD-PLANT REPLACEMENT	
DRAWN BY	H.DHAMELIYA	CHECKED BY	J.RITCHIE
DATE	05-SEP-24	REVISION	1.0
SHEET SIZE	C	SHEET NO.	1 OF 1

24009 MP905

1

2

3

4

5

A

B

C

D

E

A

B

C

D

E

1

2

3

4

5

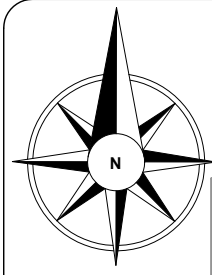

SITE KEY

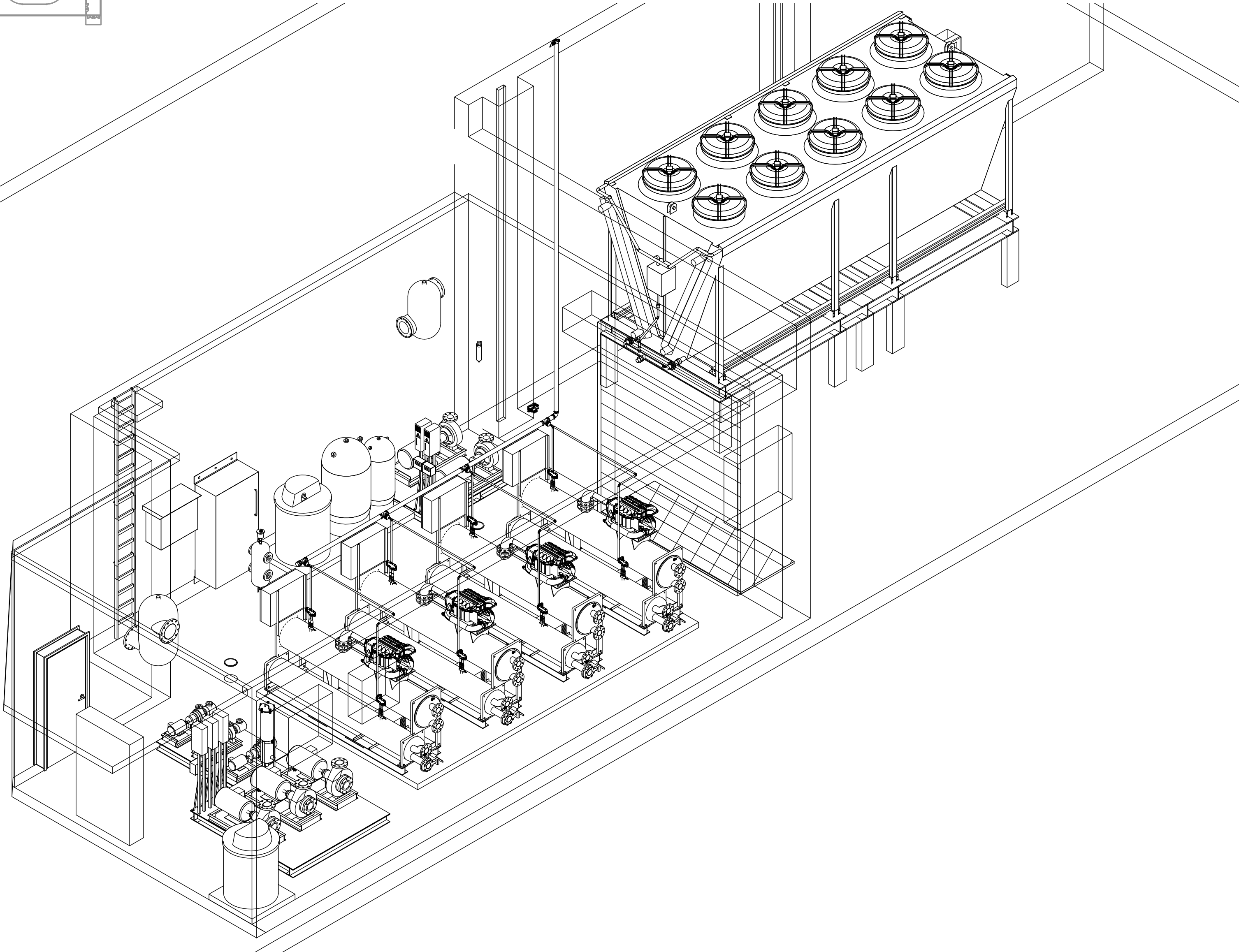
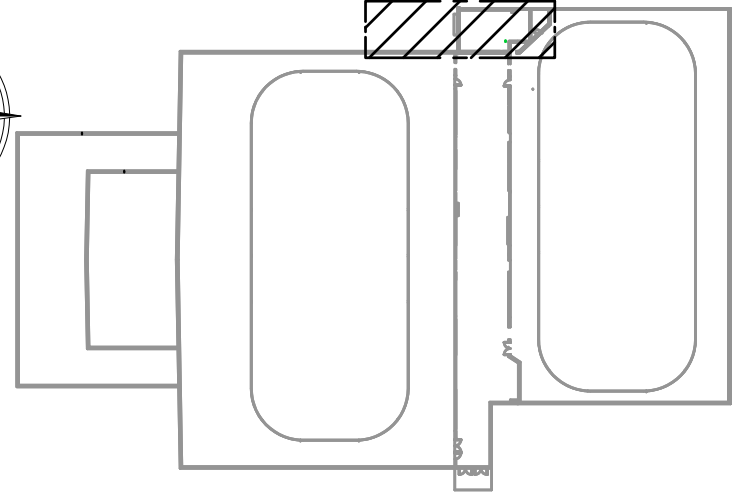

ISOMETRIC VIEW
SCALE 1/4"=1'-0"

RELIEF PIPING ISOMETRIC VIEW

NOTES:

- ALL PIPING ARE HIDDEN FOR CLARITY
- EF AND IL ARE HIDDEN FOR CLARITY

NOTES

REFERENCE DEFINITION	
SHEET COLUMN	SHEET ROW
SHEET NUMBER	(#, X#)

COPYRIGHT AND DISCLAIMER
 THIS WORK IS THE SOLE PROPERTY OF I.B. STOREY INC AND IS INTENDED SOLELY FOR THE INFORMATION OF THE CLIENT. ALL RIGHTS RESERVED. THE WORK MAY NOT BE REPRODUCED OR DISTRIBUTED, WHOLE OR IN PART, WITHOUT THE PRIOR WRITTEN PERMISSION OF I.B. STOREY INC.
 THIS DOCUMENT MAY NOT BE USED FOR ANY OTHER PROJECTS OR WITHOUT INVOLVEMENT OF I.B. STOREY INC. ANY USE WHICH A THIRD PARTY MAKES OF THE WORK, OR ANY RELIANCE ON OR DECISIONS TO BE MADE BASED ON IT, ARE THE RESPONSIBILITY OF SUCH THIRD PARTIES.

- NOT FOR CONSTRUCTION -
 CONFIDENTIAL & PROPRIETARY

VER #	REVISIONS	DATE	BY
1.0	ISSUED FOR DETAILED DESIGN	05-SEPT-24	R.T.



CHARLOTTETOWN PE
 VAUGHAN ON
 REDINGTON SHORES FL
 PLANO, TX

WWW.IBSTOREY.COM

STAMP

DRAWING NUMBER 24009 MP907	
DRAWING NAME RELIEF PIPING ISOMETRIC VIEW	
CLIENT SPRINGFIELD PARK DISTRICT	
PROJECT SPRINGFIELD-PLANT REPLACEMENT	
DRAWN BY R.THOMAS	CHECKED BY J.RITCHIE
DATE 05-SEP-24	REVISION 1.0
SHEET SIZE C	SHEET NO. 1 OF 1

24009 MP907

1

2

3

4

5

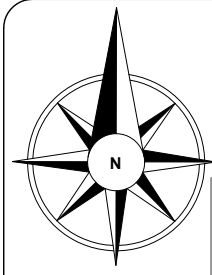

SITE KEY

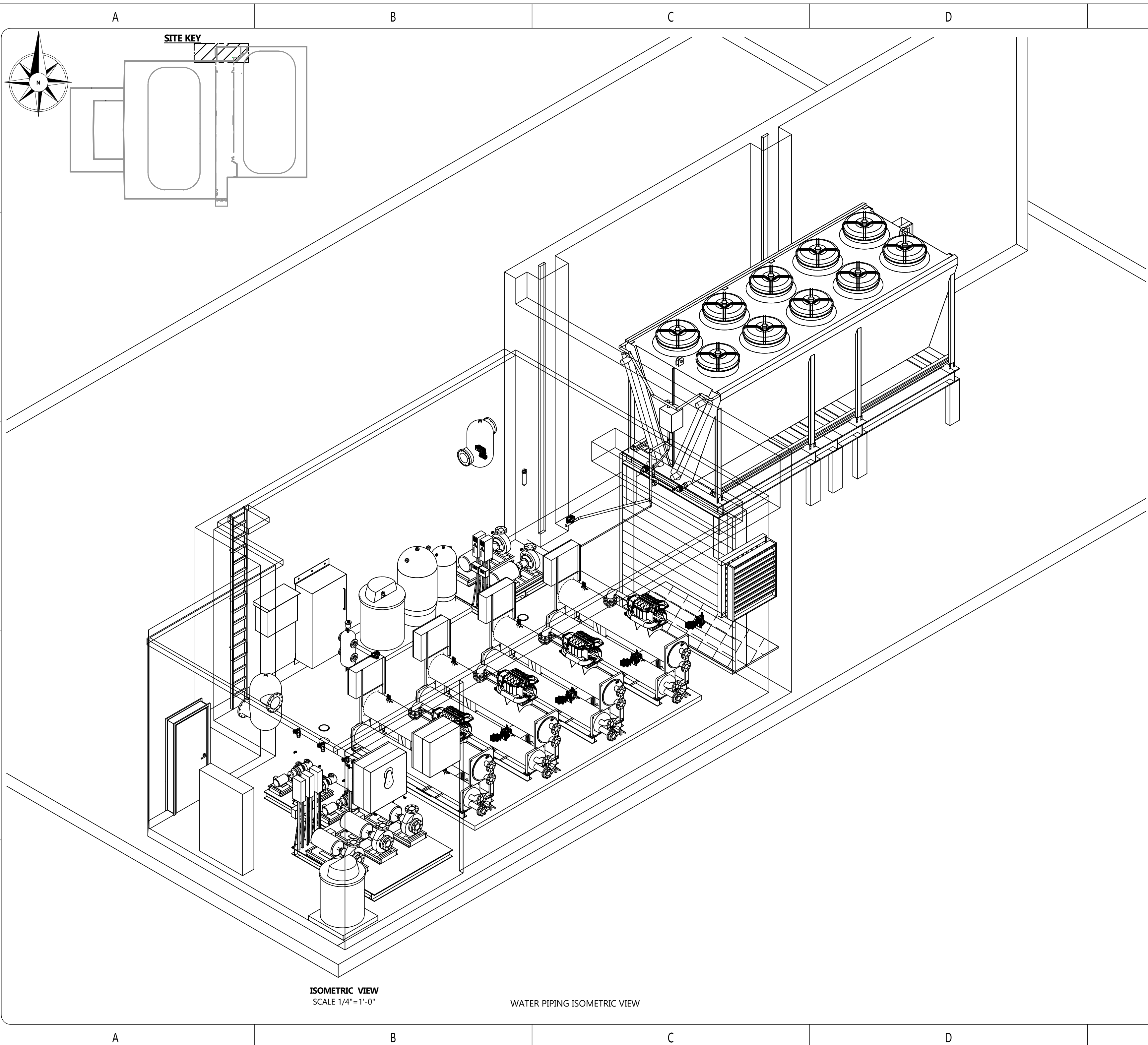
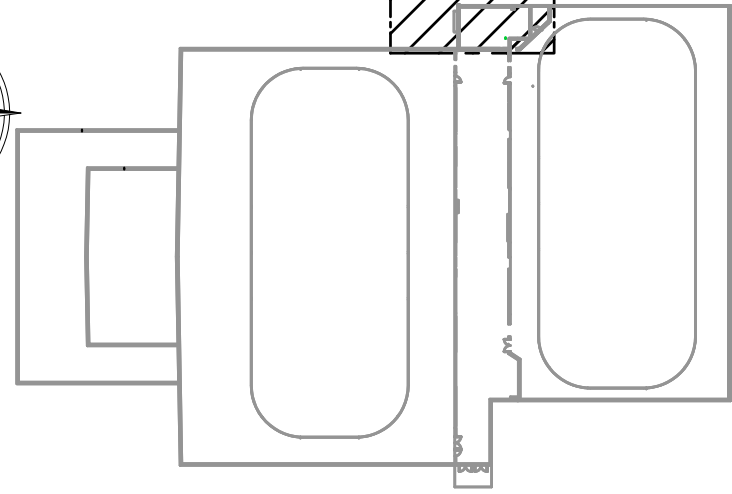

ISOMETRIC VIEW
SCALE 1/4" = 1'-0"

WATER PIPING ISOMETRIC VIEW

NOTES

REFERENCE DEFINITION	
SHEET COLUMN	SHEET ROW
SHEET NUMBER	(#, X#)

COPYRIGHT AND DISCLAIMER
 THIS WORK IS THE SOLE PROPERTY OF I.B. STOREY INC AND IS INTENDED SOLELY FOR THE INFORMATION OF THE CLIENT. ALL RIGHTS RESERVED. THE WORK MAY NOT BE REPRODUCED OR DISTRIBUTED, WHOLE OR IN PART, WITHOUT THE PRIOR WRITTEN PERMISSION OF I.B. STOREY INC.
 THIS DOCUMENT MAY NOT BE USED FOR ANY OTHER PROJECTS OR WITHOUT INVOLVEMENT OF I.B. STOREY INC. ANY USE WHICH A THIRD PARTY MAKES OF THE WORK, OR ANY RELIANCE ON OR DECISIONS TO BE MADE BASED ON IT, ARE THE RESPONSIBILITY OF SUCH THIRD PARTIES.

- NOT FOR CONSTRUCTION -
 CONFIDENTIAL & PROPRIETARY

VER #	REVISIONS	DATE	BY
2.0	ISSUED FOR DETAILED DESIGN	05-SEPT-24	H.D.
1.0	ISSUED FOR SCHEMATIC DESIGN	28-JUN-24	H.D.



CHARLOTTETOWN PE
 VAUGHAN ON
 REDINGTON SHORES FL
 PLANO, TX

WWW.IBSTOREY.COM

STAMP

DRAWING NUMBER 24009 MP905	
DRAWING NAME WATER PIPING ISOMETRIC VIEW	
CLIENT SPRINGFIELD PARK DISTRICT	
PROJECT SPRINGFIELD-PLANT REPLACEMENT	
DRAWN BY H.DHAMELIYA	CHECKED BY J.RITCHIE
DATE 05-SEP-24	REVISION 1.0
SHEET SIZE C	SHEET NO. 1 OF 1

24009 MP909

1

2

3

4

5

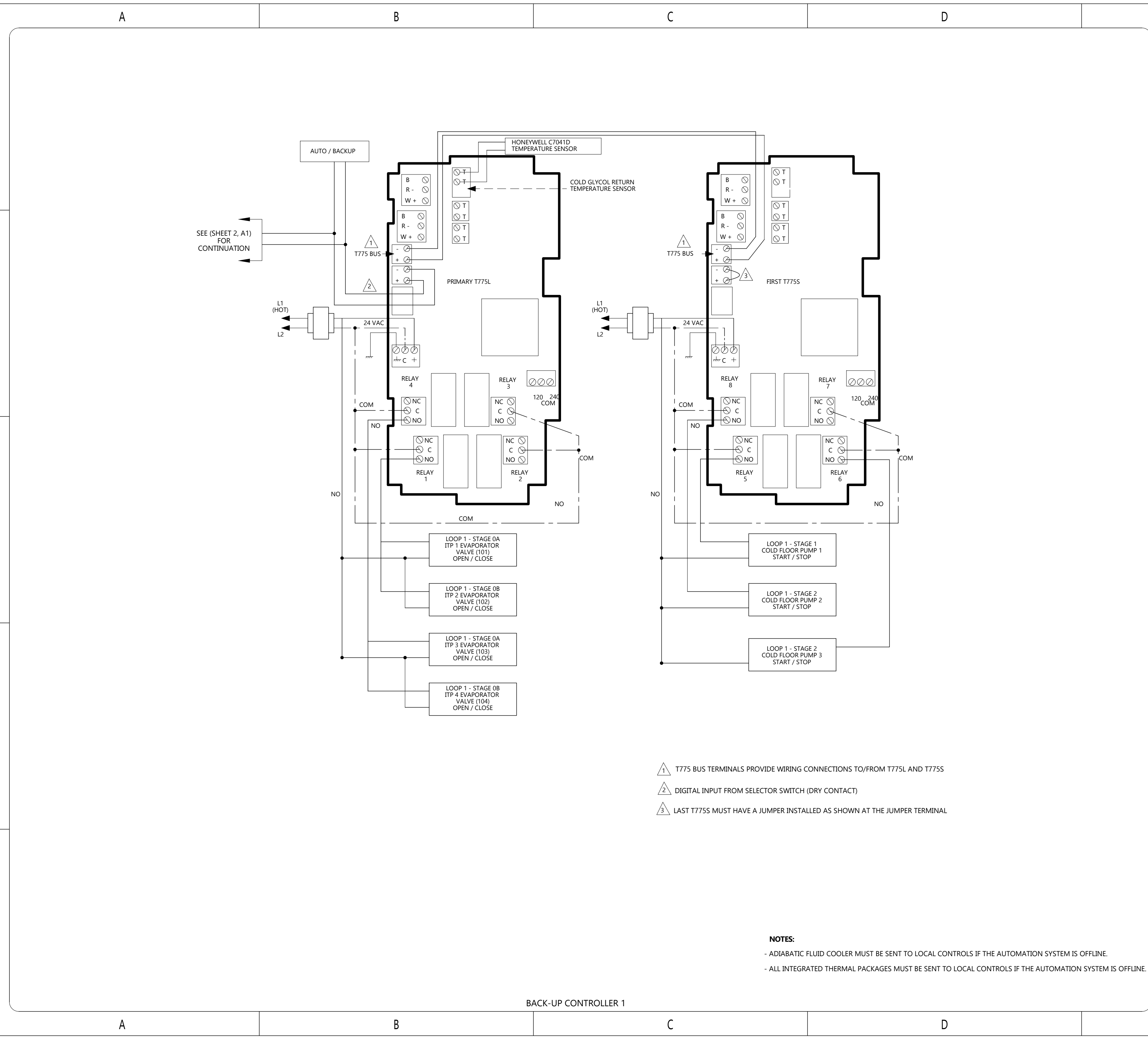

BACK-UP CONTROLLER 1

- ⚠ T775 BUS TERMINALS PROVIDE WIRING CONNECTIONS TO/FROM T775L AND T775S
- ⚠ DIGITAL INPUT FROM SELECTOR SWITCH (DRY CONTACT)
- ⚠ LAST T775S MUST HAVE A JUMPER INSTALLED AS SHOWN AT THE JUMPER TERMINAL

NOTES:
 - ADIABATIC FLUID COOLER MUST BE SENT TO LOCAL CONTROLS IF THE AUTOMATION SYSTEM IS OFFLINE.
 - ALL INTEGRATED THERMAL PACKAGES MUST BE SENT TO LOCAL CONTROLS IF THE AUTOMATION SYSTEM IS OFFLINE.

NOTES

---	NEW
---	EXISTING

REFERENCE DEFINITION

SHEET COLUMN	SHEET ROW
(#, X#)	

COPYRIGHT AND DISCLAIMER
 THIS WORK IS THE SOLE PROPERTY OF I.B. STOREY INC AND IS INTENDED SOLELY FOR THE INFORMATION OF THE CLIENT. ALL RIGHTS RESERVED. THE WORK MAY NOT BE REPRODUCED OR DISTRIBUTED, WHOLE OR IN PART, WITHOUT THE PRIOR WRITTEN PERMISSION OF I.B. STOREY INC.
 THIS DOCUMENT MAY NOT BE USED FOR ANY OTHER PROJECTS OR WITHOUT INVOLVEMENT OF I.B. STOREY INC. ANY USE WHICH A THIRD PARTY MAKES OF THE WORK, OR ANY RELIANCE ON OR DECISIONS TO BE MADE BASED ON IT, ARE THE RESPONSIBILITY OF SUCH THIRD PARTIES.

CONFIDENTIAL & PROPRIETARY

1.0	ISSUED FOR DETAILED DESIGN	05-SEP-24	H.A.
VER #	REVISIONS	DATE	BY



CHARLOTTETOWN PE
 VAUGHAN ON
 REDINGTON SHORES FL
 PLANO TX
 WWW.IBSTOREY.COM

STAMP

DRAWING NUMBER 24009 M-603	
DRAWING NAME BACKUP CONTROLLER	
CLIENT SPRINGFIELD PARK DISTRICT	
PROJECT SPRINGFIELD PLANT REPLACEMENT	
DRAWN BY H.AKAR	CHECKED BY J.RITCHIE
DATE 05-SEP-24	REVISION 1.0
SHEET SIZE C	SHEET NO. 1 OF 2

24009 M-603

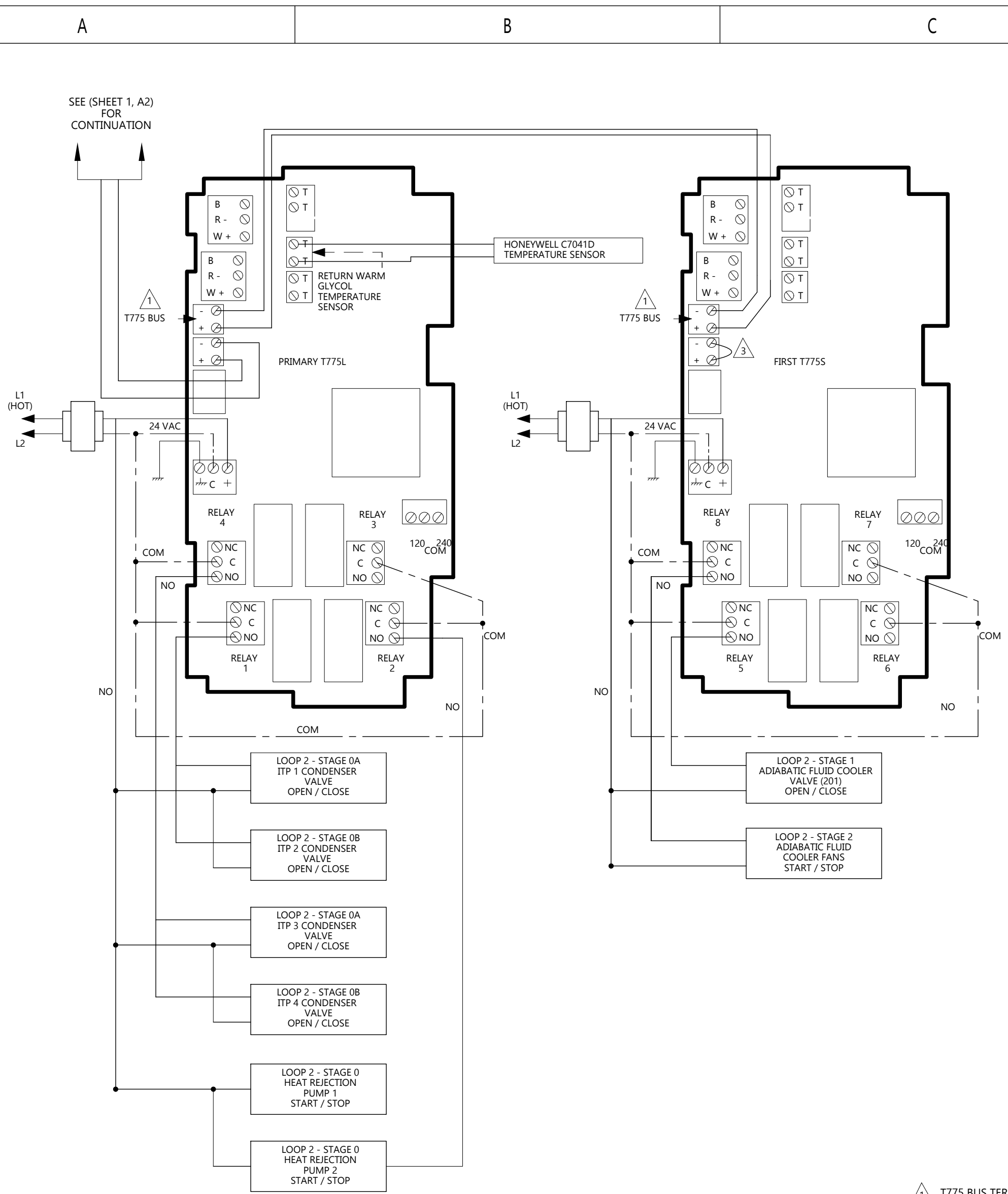

- ⚠ T775 BUS TERMINALS PROVIDE WIRING CONNECTIONS TO/FROM T775L AND T775S
- ⚠ DIGITAL INPUT FROM SELECTOR SWITCH (DRY CONTACT)
- ⚠ LAST T775S MUST HAVE A JUMPER INSTALLED AS SHOWN AT THE JUMPER TERMINAL

NOTES:

- ADIABATIC FLUID COOLER MUST BE SENT TO LOCAL CONTROLS IF THE AUTOMATION SYSTEM IS OFFLINE.
- ALL INTEGRATED THERMAL PACKAGES MUST BE SENT TO LOCAL CONTROLS IF THE AUTOMATION SYSTEM IS OFFLINE.

BACK-UP CONTROLLER 2

NOTES

---	NEW
---	EXISTING

REFERENCE DEFINITION

SHEET COLUMN	SHEET ROW
SHEET NUMBER	(#, X#)

COPYRIGHT AND DISCLAIMER
 THIS WORK IS THE SOLE PROPERTY OF I.B. STOREY INC AND IS INTENDED SOLELY FOR THE INFORMATION OF THE CLIENT. ALL RIGHTS RESERVED. THE WORK MAY NOT BE REPRODUCED OR DISTRIBUTED, WHOLE OR IN PART, WITHOUT THE PRIOR WRITTEN PERMISSION OF I.B. STOREY INC.
 THIS DOCUMENT MAY NOT BE USED FOR ANY OTHER PROJECTS OR WITHOUT INVOLVEMENT OF I.B. STOREY INC. ANY USE WHICH A THIRD PARTY MAKES OF THE WORK, OR ANY RELIANCE ON OR DECISIONS TO BE MADE BASED ON IT, ARE THE RESPONSIBILITY OF SUCH THIRD PARTIES.

CONFIDENTIAL & PROPRIETARY

1.0	ISSUED FOR DETAILED DESIGN	05-SEP-24	H.A.
VER #	REVISIONS	DATE	BY

I.B. STOREY
 Risk Engineering Experts

CHARLOTTETOWN PE
 VAUGHAN ON
 REDINGTON SHORES FL
 PLANO TX

WWW.IBSTOREY.COM

STAMP

DRAWING NUMBER 24009 M-603	
DRAWING NAME BACKUP CONTROLLER	
CLIENT SPRINGFIELD PARK DISTRICT	
PROJECT SPRINGFIELD PLANT REPLACEMENT	
DRAWN BY H.AKAR	CHECKED BY J.RITCHIE
DATE 05-SEP-24	REVISION 1.0
SHEET SIZE C	SHEET NO. 2 OF 2

24009 M-603

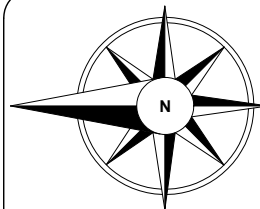

SITE KEY

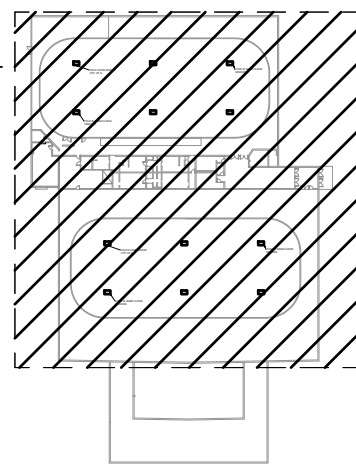

AI	040034
AI	050018
AI	050022
AI	050026

T	H
CO	CO2

AI	040014
----	--------

AI	040013
----	--------

AI	040012
----	--------

AI	040024
----	--------

COLD FLOOR SENSOR
(TYP. OF 6)

COLD & WARM FLOOR
SENSORS

RINK 2

AI	040015
----	--------

AI	040016
----	--------

AI	040017
----	--------

AI	040031
----	--------

COLD & WARM FLOOR
SENSORS

AI	040035
----	--------

AI	050019
----	--------

AI	050023
----	--------

AI	050027
----	--------

T	H
CO	CO2

CONTROL
PANEL

AI	050011
AI	040029
AI	050009
AI	050012

CO2
T
H
PPM

AI	040027
----	--------

AI	040032
AI	050016
AI	050020
AI	050024

T	H
CO	CO2

AI	040006
----	--------

AI	040004
----	--------

AI	040005
----	--------

AI	040023
----	--------

COLD FLOOR SENSOR
(TYP. OF 6)

COLD & WARM FLOOR
SENSORS

RINK 1

AI	040007
----	--------

AI	040008
----	--------

AI	040009
----	--------

COLD & WARM FLOOR
SENSORS

AI	040030
----	--------

AI	040033
AI	050017
AI	050021
AI	050025

T	H
CO	CO2

SEE DETAIL T - MR503 (10, B3) FOR RINK
FLOOR SENSORS LOCATIONS PLAN

SEE DETAIL U - MR503 (10, A5) FOR
COLD & WARM RINK INFLOOR SENSORS

SEE DETAIL V - MR503 (10, C5) FOR
COLD INFLOOR SENSOR

NOTES

SYMBOL LEGEND

T	TEMPERATURE SENSOR
H	HUMIDITY SENSOR
CO	CARBON MONOXIDE SENSOR
CO2	CARBON DIOXIDE SENSOR
PPM	REFRIGERANT DETECTOR

REFERENCE DEFINITION

SHEET COLUMN	SHEET ROW
(#, X#)	

COPYRIGHT AND DISCLAIMER

THIS WORK IS THE SOLE PROPERTY OF I.B. STOREY INC AND IS
INTENDED SOLELY FOR THE INFORMATION OF THE CLIENT. ALL
RIGHTS RESERVED. THE WORK MAY NOT BE REPRODUCED OR
DISTRIBUTED, WHOLE OR IN PART, WITHOUT THE PRIOR
WRITTEN PERMISSION OF I.B. STOREY INC.
THIS DOCUMENT MAY NOT BE USED FOR ANY OTHER
PROJECTS OR WITHOUT INVOLVEMENT OF I.B. STOREY INC.
ANY USE WHICH A THIRD PARTY MAKES OF THE WORK, OR
ANY RELIANCE ON OR DECISIONS TO BE MADE BASED ON IT,
ARE THE RESPONSIBILITY OF SUCH THIRD PARTIES.

- NOT FOR CONSTRUCTION -
CONFIDENTIAL & PROPRIETARY

2.0	ISSUED FOR DETAILED DESIGN	05-SEP-24	H.A.
1.0	ISSUED FOR SCHEMATIC DESIGN	28-JUN-24	H.A.
VER #	REVISIONS	DATE	BY



CHARLOTTETOWN PE
VAUGHAN ON
REDINGTON SHORES FL
PLANO TX

WWW.IBSTOREY.COM

STAMP

DRAWING NUMBER	24009 MI101		
DRAWING NAME	AUTOMATION PLAN		
CLIENT	SPRINGFIELD PARK DISTRICT		
PROJECT	SPRINGFIELD-PLANT REPLACEMENT		
DRAWN BY	H.AKAR	CHECKED BY	J.RITCHIE
DATE	05-SEP-24	REVISION	2.0
SHEET SIZE	C	SHEET NO.	1 OF 1

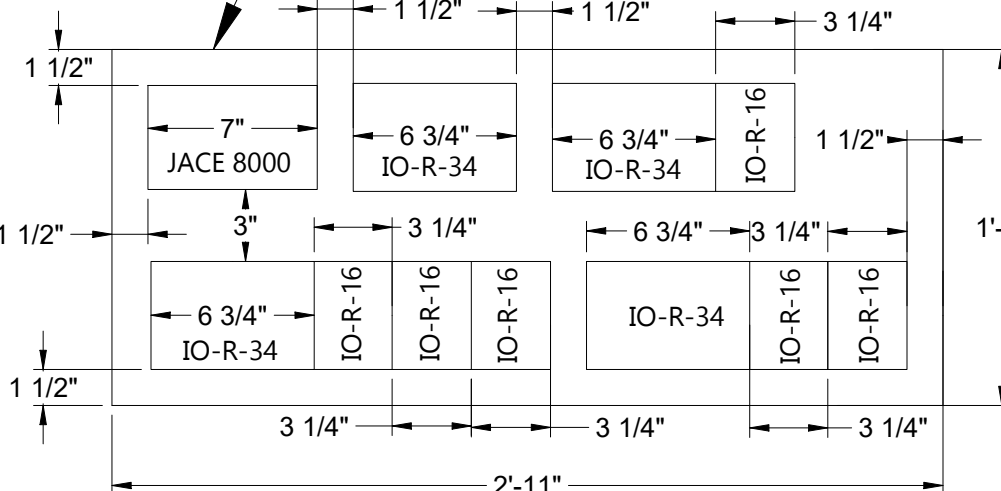

CONTROLLERS SPACE REQUIREMENT
SCALE 3"=2'-0"

AUTOMATION PLAN
SCALE 1"=20'-0"

24009 MI101

1

2

3

4

5

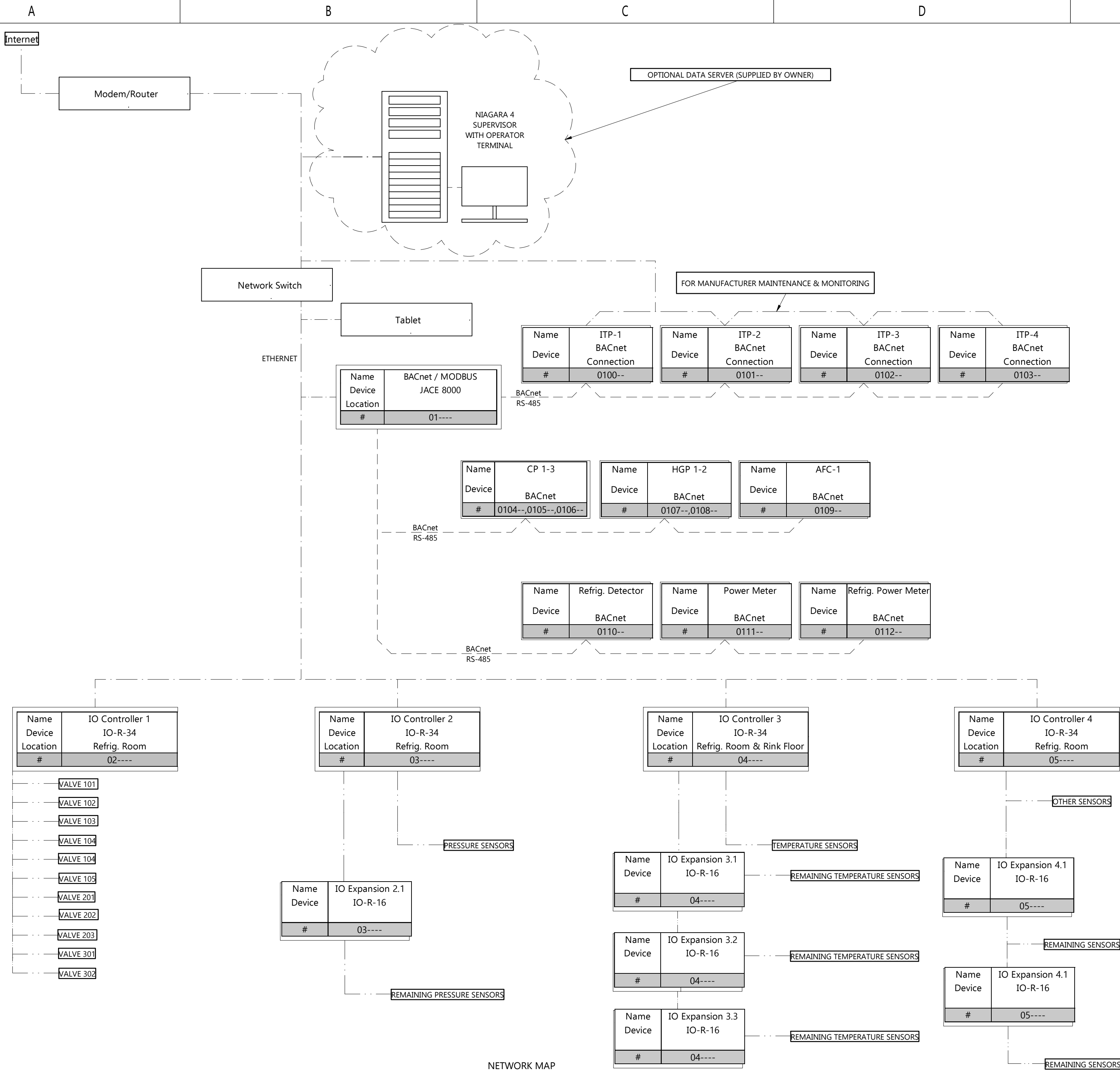

NOTES

- CAT 6/ETHERNET
- RS-485
- CONTROL WIRE

REFERENCE DEFINITION

SHEET COLUMN SHEET ROW (#, X#)

COPYRIGHT AND DISCLAIMER
 THIS WORK IS THE SOLE PROPERTY OF I.B. STOREY INC AND IS INTENDED SOLELY FOR THE INFORMATION OF THE CLIENT. ALL RIGHTS RESERVED. THE WORK MAY NOT BE REPRODUCED OR DISTRIBUTED, WHOLE OR IN PART, WITHOUT THE PRIOR WRITTEN PERMISSION OF I.B. STOREY INC.
 THIS DOCUMENT MAY NOT BE USED FOR ANY OTHER PROJECTS OR WITHOUT INVOLVEMENT OF I.B. STOREY INC. ANY USE WHICH A THIRD PARTY MAKES OF THE WORK, OR ANY RELIANCE ON OR DECISIONS TO BE MADE BASED ON IT, ARE THE RESPONSIBILITY OF SUCH THIRD PARTIES.

- NOT FOR CONSTRUCTION -
 CONFIDENTIAL & PROPRIETARY

VER #	REVISIONS	DATE	BY
2.0	ISSUED FOR DETAILED DESIGN	05-SEP-24	H.A.
1.0	ISSUED FOR SCHEMATIC DESIGN	28-JUN-24	H.A.

I.B. STOREY
 Rink Engineering Experts

CHARLOTTETOWN PE
 VAUGHAN ON
 REDINGTON SHORES FL
 PLANO TX

WWW.IBSTOREY.COM

STAMP

DRAWING NUMBER	24009 MI601
DRAWING NAME	AUTOMATION SCHEMATICS
CLIENT	SPRINGFIELD PARK DISTRICT
PROJECT	SPRINGFIELD - PLANT REPLACEMENT
DRAWN BY	H.AKAR
CHECKED BY	J.RITCHIE
DATE	05-SEP-24
REVISION	2.0
SHEET SIZE	C
SHEET NO.	1 OF 7

24009 MI601

NETWORK MAP

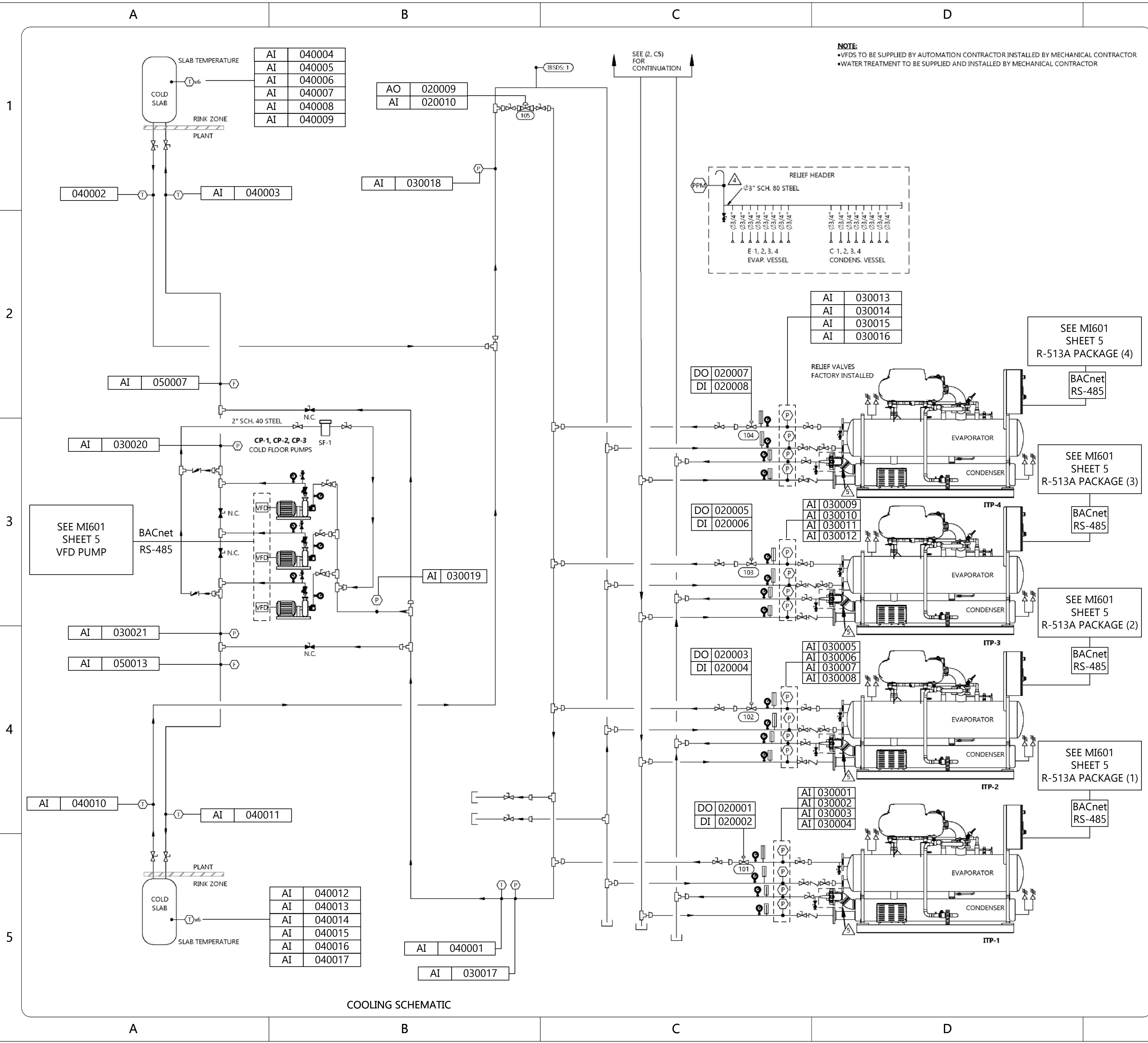

COOLING SCHEMATIC

NOTE:
 •VFDs TO BE SUPPLIED BY AUTOMATION CONTRACTOR INSTALLED BY MECHANICAL CONTRACTOR
 •WATER TREATMENT TO BE SUPPLIED AND INSTALLED BY MECHANICAL CONTRACTOR

NOTES

NEW	EXISTING
	ISOLATING VALVE
	MODULATING VALVE
	SOLENOID VALVE
	EXPANSION VALVE
	RELIEF VALVE
	STRAINER
	CHECK VALVE
	BALANCING VALVE
	DRAIN
	FLO-TREX VALVE
	SUCTION GUIDE
	PRESSURE SENSOR
	TEMPERATURE SENSOR
	FLOW METER
	LEVEL SWITCH
	RELIEF LINE
	PRESSURE GAUGE
	THERMOMETER
	REFRIGERANT DETECTOR

REFERENCE DEFINITION

SHEET COLUMN	SHEET ROW
(#)	(X#)

COPYRIGHT AND DISCLAIMER
 THIS WORK IS THE SOLE PROPERTY OF I.B. STOREY INC AND IS INTENDED SOLELY FOR THE INFORMATION OF THE CLIENT. ALL RIGHTS RESERVED. THE WORK MAY NOT BE REPRODUCED OR DISTRIBUTED, WHOLE OR IN PART, WITHOUT THE PRIOR WRITTEN PERMISSION OF I.B. STOREY INC. THIS DOCUMENT MAY NOT BE USED FOR ANY OTHER PROJECTS OR WITHOUT INVOLVEMENT OF I.B. STOREY INC. ANY USE WHICH A THIRD PARTY MAKES OF THE WORK, OR ANY RELIANCE ON OR DECISIONS TO BE MADE BASED ON IT, ARE THE RESPONSIBILITY OF SUCH THIRD PARTIES.

- NOT FOR CONSTRUCTION -
 CONFIDENTIAL & PROPRIETARY

2.0	ISSUED FOR DETAILED DESIGN	6-SEP-24	H.A.
1.0	ISSUED FOR SCHEMATIC DESIGN	28-JUN-24	H.A.
VER #	REVISIONS	DATE	BY



CHARLOTTETOWN PE
 VAUGHAN ON
 REDINGTON SHORES FL
 PLANO TX
 WWW.IBSTOREY.COM

STAMP

DRAWING NUMBER	24-009 MI601		
DRAWING NAME	Automation Schematics		
CLIENT	Springfield Park District		
PROJECT	Springfield - Plant Replacement		
DRAWN BY	H.AKAR	CHECKED BY	C.CUDMORE
DATE	6-SEP-24	REVISION	2.0
SHEET SIZE	C	SHEET NO.	2 OF 7

24-009 MI601

1

2

3

4

5

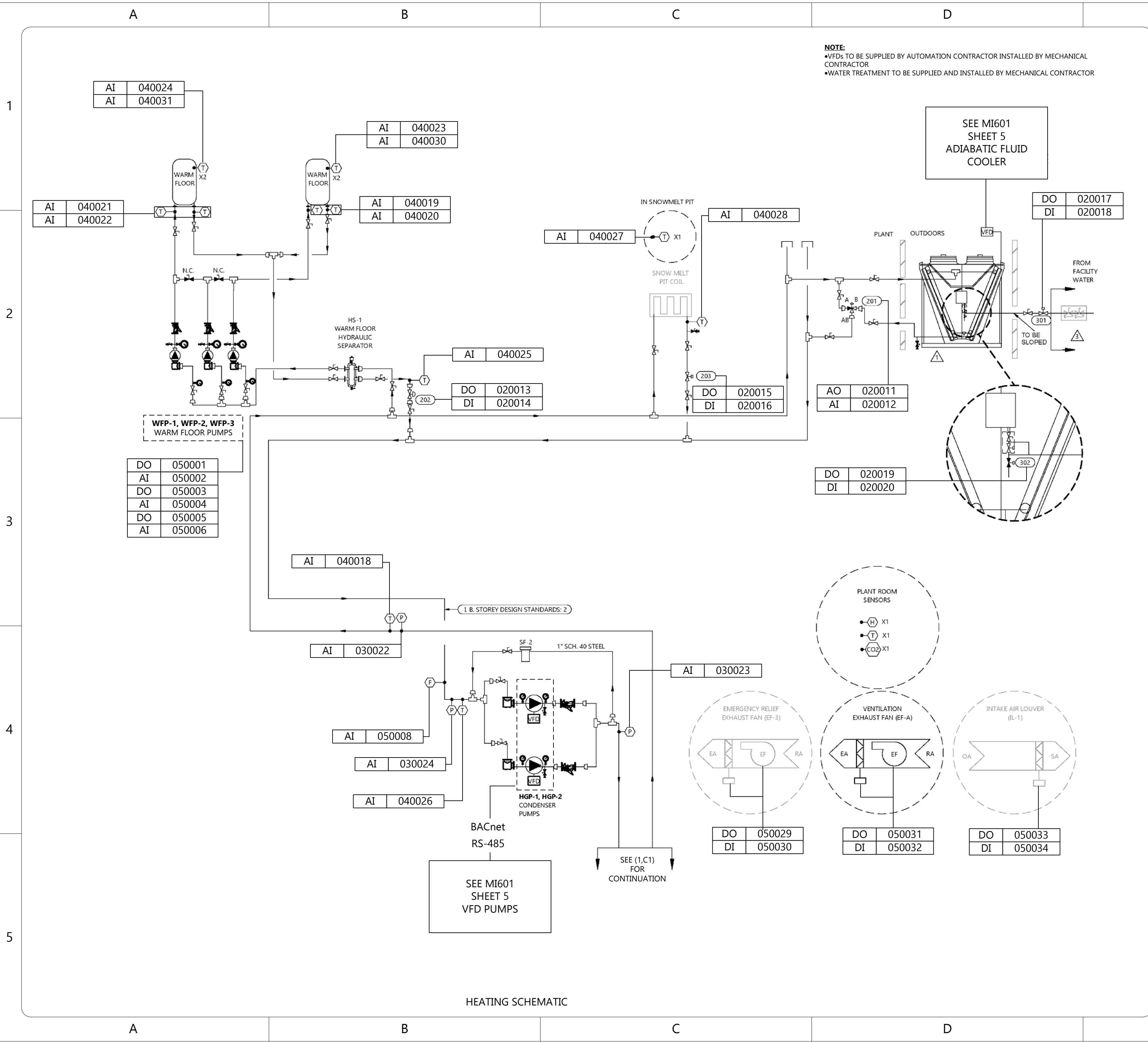

NOTE:
 •VFDs TO BE SUPPLIED BY AUTOMATION CONTRACTOR INSTALLED BY MECHANICAL CONTRACTOR
 •WATER TREATMENT TO BE SUPPLIED AND INSTALLED BY MECHANICAL CONTRACTOR

NOTES

—	NEW
—	EXISTING

⊘	ISOLATING VALVE
⊘	MODULATING VALVE
⊘	SOLENOID VALVE
⊘	EXPANSION VALVE
⊘	RELIEF VALVE
⊘	STRAINER
⊘	CHECK VALVE
⊘	BALANCING VALVE
⊘	DRAIN
⊘	FLO-TREX VALVE
⊘	SUCTION GUIDE
⊘	PRESSURE SENSOR
⊘	TEMPERATURE SENSOR
⊘	FLOW METER
⊘	LEVEL SWITCH
⊘	RELIEF LINE
⊘	PRESSURE GAUGE
⊘	THERMOMETER
⊘	PPM REFRIGERANT DETECTOR

REFERENCE DEFINITION

SHEET COLUMN	SHEET ROW
(#)	(#, X#)

COPYRIGHT AND DISCLAIMER
 THIS WORK IS THE SOLE PROPERTY OF I.B. STOREY INC AND IS INTENDED SOLELY FOR THE INFORMATION OF THE CLIENT. ALL RIGHTS RESERVED. THE WORK MAY NOT BE REPRODUCED OR DISTRIBUTED, WHOLE OR IN PART, WITHOUT THE PRIOR WRITTEN PERMISSION OF I.B. STOREY INC.
 THIS DOCUMENT MAY NOT BE USED FOR ANY OTHER PROJECTS OR WITHOUT INVOLVEMENT OF I.B. STOREY INC. ANY USE WHICH A THIRD PARTY MAKES OF THE WORK, OR ANY RELIANCE ON OR DECISIONS TO BE MADE BASED ON IT, ARE THE RESPONSIBILITY OF SUCH THIRD PARTIES.

- NOT FOR CONSTRUCTION -
 CONFIDENTIAL & PROPRIETARY

2.0	ISSUED FOR DETAILED DESIGN	06-SEP-24	H.A.
1.0	ISSUED FOR SCHEMATIC DESIGN	28-AUG-24	H.A.
VER #	REVISIONS	DATE	BY

CHARLOTTETOWN PE
 VAUGHAN ON
 REDINGTON SHORES FL
 PLANO TX
 WWW.IBSTOREY.COM

STAMP

DRAWING NUMBER	24-009 MI601
DRAWING NAME	Automation Schematics
CLIENT	Springfield Park District
PROJECT	Springfield - Plant Replacement
DRAWN BY	H.Akar
CHECKED BY	C.CUDMORE
DATE	6-SEP-24
REVISION	2.0
SHEET SIZE	C
SHEET NO.	3 OF 7

24-009 MI601

1

2

3

4

5

HEATING SCHEMATIC

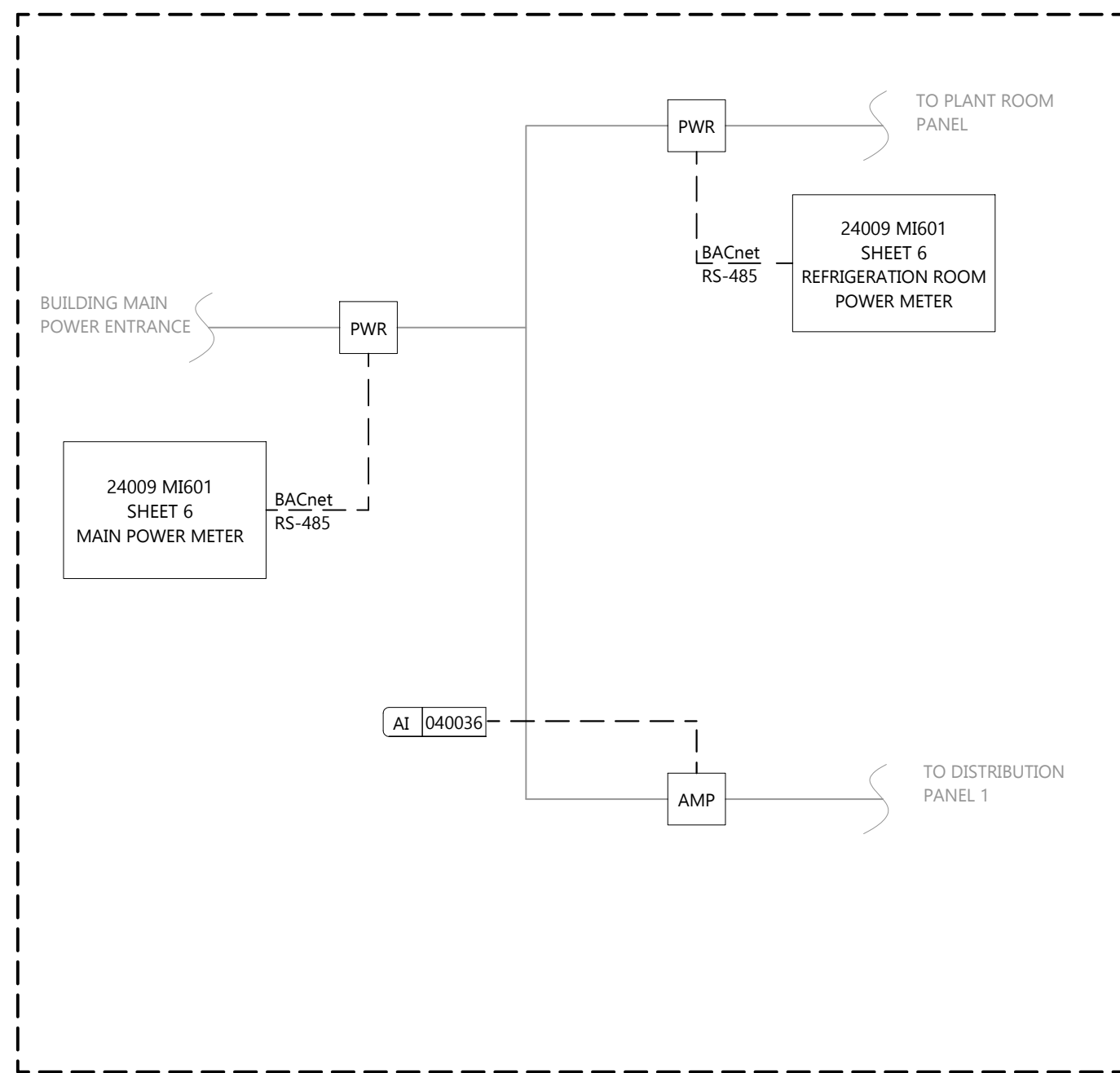

BUILDING POWER

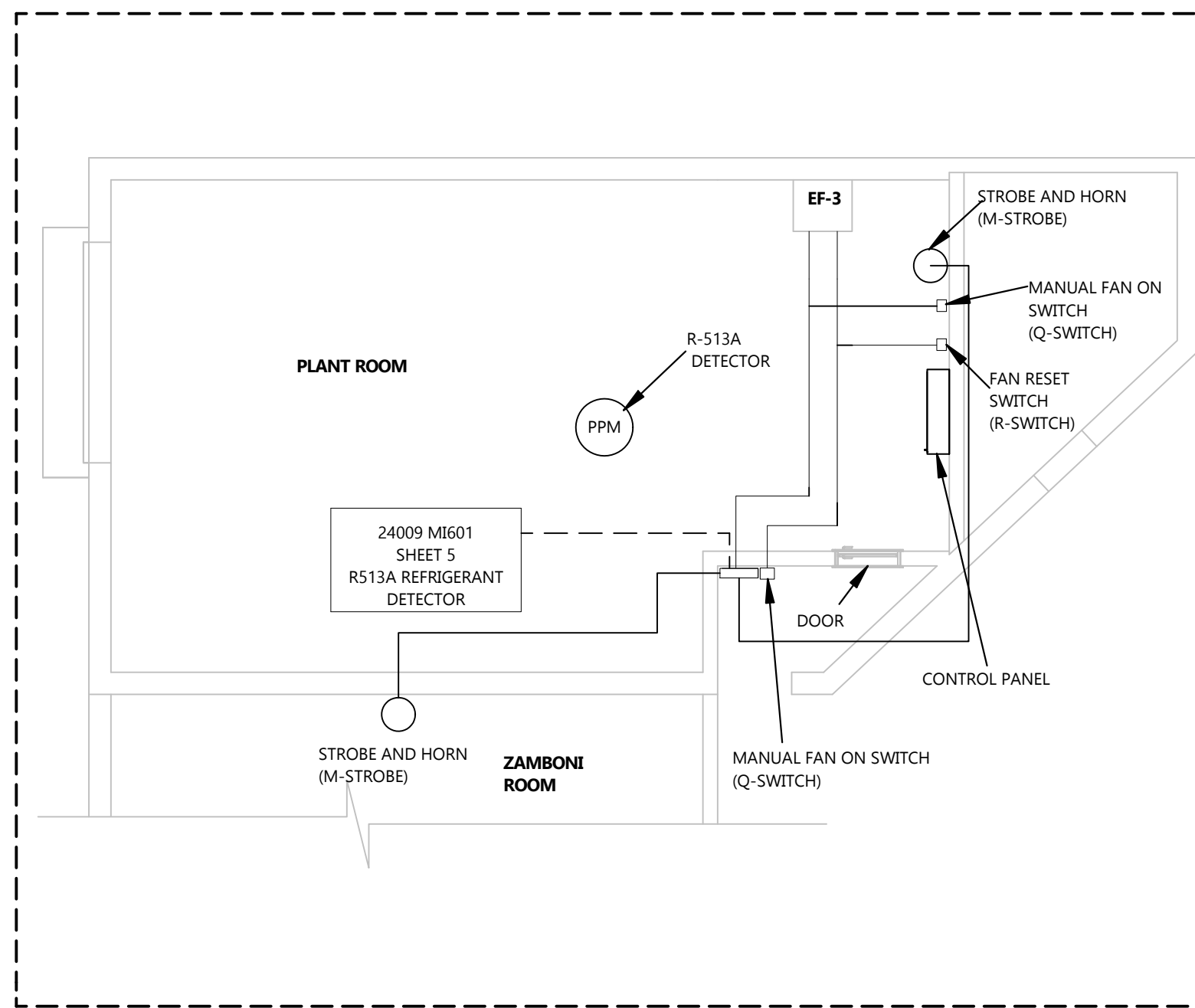

REFRIGERANT DETECTOR

NOTES

REFERENCE DEFINITION	
SHEET COLUMN	SHEET ROW
SHEET NUMBER	(#, X#)

COPYRIGHT AND DISCLAIMER
 THIS WORK IS THE SOLE PROPERTY OF I.B. STOREY INC AND IS INTENDED SOLELY FOR THE INFORMATION OF THE CLIENT. ALL RIGHTS RESERVED. THE WORK MAY NOT BE REPRODUCED OR DISTRIBUTED, WHOLE OR IN PART, WITHOUT THE PRIOR WRITTEN PERMISSION OF I.B. STOREY INC.
 THIS DOCUMENT MAY NOT BE USED FOR ANY OTHER PROJECTS OR WITHOUT INVOLVEMENT OF I.B. STOREY INC. ANY USE WHICH A THIRD PARTY MAKES OF THE WORK, OR ANY RELIANCE ON OR DECISIONS TO BE MADE BASED ON IT, ARE THE RESPONSIBILITY OF SUCH THIRD PARTIES.

- NOT FOR CONSTRUCTION -
CONFIDENTIAL & PROPRIETARY

VER #	REVISIONS	DATE	BY
2.0	ISSUED FOR DETAILED DESIGN	05-SEP-24	H.A.
1.0	ISSUED FOR SCHEMATIC DESIGN	28-JUN-24	H.A.



CHARLOTTETOWN PE
 VAUGHAN ON
 REDINGTON SHORES FL
 PLANO TX

WWW.IBSTOREY.COM

STAMP

DRAWING NUMBER	24009 MI601
DRAWING NAME	AUTOMATION SCHEMATICS
CLIENT	SPRINGFIELD PARK DISTRICT
PROJECT	SPRINGFIELD - PLANT REPLACEMENT
DRAWN BY	H.AKAR
CHECKED BY	J.RITCHIE
DATE	05-SEP-24
REVISION	2.0
SHEET SIZE	C
SHEET NO.	4 OF 7

24009 MI601

MISC. EQUIPMENT

BACNET CONNECTION TO ICE REFRIGERATION PACKAGE 1					
POINT NUMBER	POINT DESCRIPTION	INTEGRATED HARDWARE			
		POINT TYPE			
		ANALOG INPUT	ANALOG OUTPUT	DIGITAL INPUT	DIGITAL OUTPUT
010001	ITP-1 START/STOP				X
010002	ITP-1 STATUS			X	
010003	COLD WATER SETPOINT		X		
010004	HOT WATER SETPOINT		X		
010005	ITP-1 POWER CONSUMP.	X			
010006	ITP-1 CAPACITY (%)	X			
010007	COND. IN TEMP	X			
010008	COND. OUT TEMP	X			
010009	EVAP IN TEMP	X			
010010	EVAP OUT TEMP	X			
010011	RUNTIME	X			
010012	STARTS	X			
010013	AMPS	X			
010014	POWER FACTOR	X			
010015	VOLTAGE	X			
010016	POWER (KW)	X			
010017	ITP-1 ALARM STATE			X	
010018	ITP-1 CONDENSER VALVE COMMAND		X		
010019	ITP-1 CONDENSER VALVE FEEDBACK	X			

BACNET CONNECTION TO RINK REFRIGERATION PACKAGE 2					
POINT NUMBER	POINT DESCRIPTION	INTEGRATED HARDWARE			
		POINT TYPE			
		ANALOG INPUT	ANALOG OUTPUT	DIGITAL INPUT	DIGITAL OUTPUT
010101	ITP-2 START/STOP				X
010102	ITP-2 STATUS			X	
010103	COLD WATER SETPOINT		X		
010104	HOT WATER SETPOINT		X		
010105	ITP-2 POWER CONSUMP.	X			
010106	ITP-2 CAPACITY (%)	X			
010107	COND. IN TEMP	X			
010108	COND. OUT TEMP	X			
010109	EVAP IN TEMP	X			
010110	EVAP OUT TEMP	X			
010111	RUNTIME	X			
010112	STARTS	X			
010113	AMPS	X			
010114	POWER FACTOR	X			
010115	VOLTAGE	X			
010116	POWER (KW)	X			
010117	ITP-2 ALARM STATE			X	
010118	ITP-2 CONDENSER VALVE COMMAND		X		
010119	ITP-2 CONDENSER VALVE FEEDBACK	X			

BACNET CONNECTION TO RINK REFRIGERATION PACKAGE 3					
POINT NUMBER	POINT DESCRIPTION	INTEGRATED HARDWARE			
		POINT TYPE			
		ANALOG INPUT	ANALOG OUTPUT	DIGITAL INPUT	DIGITAL OUTPUT
010201	ITP-3 START/STOP				X
010202	ITP-3 STATUS			X	
010203	COLD WATER SETPOINT		X		
010204	HOT WATER SETPOINT		X		
010205	ITP-3 POWER CONSUMP.	X			
010206	ITP-3 CAPACITY (%)	X			
010207	COND. IN TEMP	X			
010208	COND. OUT TEMP	X			
010209	EVAP IN TEMP	X			
010210	EVAP OUT TEMP	X			
010211	RUNTIME	X			
010212	STARTS	X			
010213	AMPS	X			
010214	POWER FACTOR	X			
010215	VOLTAGE	X			
010216	POWER (KW)	X			
010217	ITP-3 ALARM STATE			X	
010218	ITP-3 CONDENSER VALVE COMMAND		X		
010219	ITP-3 CONDENSER VALVE FEEDBACK	X			

BACNET CONNECTION TO RINK REFRIGERATION PACKAGE 4					
POINT NUMBER	POINT DESCRIPTION	INTEGRATED HARDWARE			
		POINT TYPE			
		ANALOG INPUT	ANALOG OUTPUT	DIGITAL INPUT	DIGITAL OUTPUT
010301	ITP-4 START/STOP				X
010302	ITP-4 STATUS			X	
010303	COLD WATER SETPOINT		X		
010304	HOT WATER SETPOINT		X		
010305	ITP-4 POWER CONSUMP.	X			
010306	ITP-4 CAPACITY (%)	X			
010307	COND. IN TEMP	X			
010308	COND. OUT TEMP	X			
010309	EVAP IN TEMP	X			
010310	EVAP OUT TEMP	X			
010311	RUNTIME	X			
010312	STARTS	X			
010313	AMPS	X			
010314	POWER FACTOR	X			
010315	VOLTAGE	X			
010316	POWER (KW)	X			
010317	ITP-4 ALARM STATE			X	
010318	ITP-4 CONDENSER VALVE COMMAND		X		
010319	ITP-4 CONDENSER VALVE FEEDBACK	X			

BACNET CONNECTION TO VFD PUMPS					
POINT NUMBER	POINT DESCRIPTION	INTEGRATED HARDWARE			
		POINT TYPE			
		ANALOG INPUT	ANALOG OUTPUT	DIGITAL INPUT	DIGITAL OUTPUT
010401	CP-1 START/STOP				X
010402	CP-1 STATUS			X	
010403	CP-1 VFD SPEED COMMAND		X		
010404	CP-1 VFD SPEED FEEDBACK	X			
010405	CP-1 VFD AMPS	X			
010406	CP-1 VFD VOLTAGE	X			
010407	CP-1 VFD POWER FACTOR	X			
010408	CP-1 VFD POWER (KW)	X			
010501	CP-2 START/STOP				X
010502	CP-2 STATUS			X	
010503	CP-2 VFD SPEED COMMAND		X		
010504	CP-2 VFD SPEED FEEDBACK	X			
010505	CP-2 VFD AMPS	X			
010506	CP-2 VFD VOLTAGE	X			
010507	CP-2 VFD POWER FACTOR	X			
010508	CP-2 VFD POWER (KW)	X			
010601	CP-3 START/STOP				X
010602	CP-3 STATUS			X	
010603	CP-3 VFD SPEED COMMAND		X		
010604	CP-3 VFD SPEED FEEDBACK	X			
010605	CP-3 VFD AMPS	X			
010606	CP-3 VFD VOLTAGE	X			
010607	CP-3 VFD POWER FACTOR	X			
010608	CP-3 VFD POWER (KW)	X			
010701	HP-1 START/STOP				X
010702	HP-1 STATUS			X	
010703	HP-1 VFD SPEED COMMAND		X		
010704	HP-1 VFD SPEED FEEDBACK	X			
010705	HP-1 VFD AMPS	X			
010706	HP-1 VFD VOLTAGE	X			
010707	HP-1 VFD POWER FACTOR	X			
010708	HP-1 VFD POWER (KW)	X			
010801	HP-2 START/STOP				X
010802	HP-2 STATUS			X	
010803	HP-2 VFD SPEED COMMAND		X		
010804	HP-2 VFD SPEED FEEDBACK	X			
010805	HP-2 VFD AMPS	X			
010806	HP-2 VFD VOLTAGE	X			
010807	HP-2 VFD POWER FACTOR	X			
010808	HP-2 VFD POWER (KW)	X			

BACNET CONNECTION TO ADIABATIC FLUID COOLER					
POINT NUMBER	POINT DESCRIPTION	INTEGRATED HARDWARE			
		POINT TYPE			
		ANALOG INPUT	ANALOG OUTPUT	DIGITAL INPUT	DIGITAL OUTPUT
010901	FAN 1 START/STOP				X
010902	FAN 1 STATUS			X	
010903	FAN 1 SPEED COMMAND		X		
010904	FAN 1 SPEED FEEDBACK	X			
010905	FAN 2 START/STOP				X
010906	FAN 2 STATUS			X	
010907	FAN 2 SPEED COMMAND		X		
010908	FAN 2 SPEED FEEDBACK	X			
010909	FAN 3 START/STOP				X
010910	FAN 3 STATUS			X	
010911	FAN 3 SPEED COMMAND		X		
010912	FAN 3 SPEED FEEDBACK	X			
010913	FAN 4 START/STOP				X
010914	FAN 4 STATUS			X	
010915	FAN 4 SPEED COMMAND		X		
010916	FAN 4 SPEED FEEDBACK	X			
010917	FAN 5 START/STOP				X
010918	FAN 5 STATUS			X	
010919	FAN 5 SPEED COMMAND		X		
010920	FAN 5 SPEED FEEDBACK	X			
010921	FAN 6 START/STOP				X
010922	FAN 6 STATUS			X	
010923	FAN 6 SPEED COMMAND		X		
010924	FAN 6 SPEED FEEDBACK	X			
010925	FAN 7 START/STOP				X
010926	FAN 7 STATUS			X	
010927	FAN 7 SPEED COMMAND		X		
010928	FAN 7 SPEED FEEDBACK	X			
010929	FAN 8 START/STOP				X
010930	FAN 8 STATUS			X	
010931	FAN 8 SPEED COMMAND		X		
010932	FAN 8 SPEED FEEDBACK	X			
010933	FAN 9 START/STOP				X
010934	FAN 9 STATUS			X	
010935	FAN 9 SPEED COMMAND		X		
010936	FAN 9 SPEED FEEDBACK	X			
010937	FAN 10 START/STOP				X
010938	FAN 10 STATUS			X	
010939	FAN 10 SPEED COMMAND		X		
010940	FAN 10 SPEED FEEDBACK	X			
010941	MODE CONTROL		X		
010942	LEAVING GLYCOL SETPOINT		X		

BACNET CONNECTION TO R513A REFRIGERANT DETECTOR					
POINT NUMBER	POINT DESCRIPTION	INTEGRATED HARDWARE			
		POINT TYPE			
		ANALOG INPUT	ANALOG OUTPUT	DIGITAL INPUT	DIGITAL OUTPUT
011001	REFRIGERANT PPM	X			
011002	REFRIGERANT ALARM	X			

NOTES

REFERENCE DEFINITION

SHEET COLUMN SHEET NUMBER SHEET ROW (#, X#)

COPYRIGHT AND DISCLAIMER

THIS WORK IS THE SOLE PROPERTY OF I.B. STOREY INC AND IS INTENDED SOLELY FOR THE INFORMATION OF THE CLIENT. ALL RIGHTS RESERVED. THE WORK MAY NOT BE REPRODUCED OR DISTRIBUTED, WHOLE OR IN PART, WITHOUT THE PRIOR WRITTEN PERMISSION OF I.B. STOREY INC.

THIS DOCUMENT MAY NOT BE USED FOR ANY OTHER PROJECTS OR WITHOUT INVOLVEMENT OF I.B. STOREY INC. ANY USE WHICH A THIRD PARTY MAKES OF THE WORK, OR ANY RELIANCE ON OR DECISIONS TO BE MADE BASED ON IT, ARE THE RESPONSIBILITY OF SUCH THIRD PARTIES.

- NOT FOR CONSTRUCTION -
CONFIDENTIAL & PROPRIETARY

2.0	ISSUED FOR DETAILED DESIGN	05-SEP-24	H.A.
1.0	ISSUED FOR SCHEMATIC DESIGN	28-JUN-24	H.A.
VER #	REVISIONS	DATE	BY

CHARLOTTETOWN PE
VAUGHAN ON
REDINGTON SHORES FL
PLANO TX

WWW.IBSTOREY.COM

STAMP

DRAWING NUMBER	24009 MI601
DRAWING NAME	AUTOMATION SCHEMATICS
CLIENT	SPRINGFIELD PARK DISTRICT
PROJECT	SPRINGFIELD - PLANT REPLACEMENT
DRAWN BY	H.AKAR
CHECKED BY	J.RITCHIE
DATE	05-SEP-24
REVISION	2.0
SHEET SIZE	C
SHEET NO.	5 OF 7

24009 MI601

BACNET CONNECTION TO POWER METER					
POINT NUMBER	POINT DESCRIPTION	INTEGRATED HARDWARE			
		POINT TYPE			
		ANALOG INPUT	ANALOG OUTPUT	DIGITAL INPUT	DIGITAL OUTPUT
011101	ENERGY SUM - KWH	X			
011102	POWER SUM W	X			
011103	POWER A W	X			
011104	POWER B W	X			
011105	POWER C W	X			
011106	VOLT AVG LN V	X			
011107	VOLT A V	X			
011108	VOLT B V	X			
011109	VOLT C V	X			
011110	VOLT AVG LL V	X			
011111	FREQ HZ	X			
011112	CURRENT A AMP	X			
011113	CURRENT B AMP	X			
011114	CURRENT C AMP	X			
011115	POWER FACTOR AVG	X			
011116	POWER FACTOR A	X			
011117	POWER FACTOR B	X			
011118	POWER FACTOR C	X			
011119	DEMAND SUM W	X			
011120	DEMAND A	X			
011121	DEMAND B	X			
011122	DEMAND C	X			

BACNET CONNECTION TO REFRIGERATION ROOM POWER METER					
POINT NUMBER	POINT DESCRIPTION	INTEGRATED HARDWARE			
		POINT TYPE			
		ANALOG INPUT	ANALOG OUTPUT	DIGITAL INPUT	DIGITAL OUTPUT
011201	ENERGY SUM - KWH	X			
011202	POWER SUM W	X			
011203	POWER A W	X			
011204	POWER B W	X			
011205	POWER C W	X			
011206	VOLT AVG LN V	X			
011207	VOLT A V	X			
011208	VOLT B V	X			
011209	VOLT C V	X			
011210	VOLT AVG LL V	X			
011211	FREQ HZ	X			
011212	CURRENT A AMP	X			
011213	CURRENT B AMP	X			
011214	CURRENT C AMP	X			
011215	POWER FACTOR AVG	X			
011216	POWER FACTOR A	X			
011217	POWER FACTOR B	X			
011218	POWER FACTOR C	X			
011219	DEMAND SUM W	X			
011220	DEMAND A	X			
011221	DEMAND B	X			
011222	DEMAND C	X			

IO-CONTROLLER 1					
POINT NUMBER	POINT DESCRIPTION	INTEGRATED HARDWARE			
		POINT TYPE			
		ANALOG INPUT	ANALOG OUTPUT	DIGITAL INPUT	DIGITAL OUTPUT
020001	ITP-1 EVAP. VALVE 101 OPEN/CLOSE				X
020002	ITP-1 EVAP. VALVE 101 FEEDBACK			X	
020003	ITP-2 EVAP. VALVE 102 OPEN/CLOSE				X
020004	ITP-2 EVAP. VALVE 102 FEEDBACK			X	
020005	ITP-3 EVAP. VALVE 103 OPEN/CLOSE				X
020006	ITP-3 EVAP. VALVE 103 FEEDBACK			X	
020007	ITP-4 EVAP. VALVE 104 OPEN/CLOSE				X
020008	ITP-4 EVAP. VALVE 104 FEEDBACK			X	
020009	STARTUP BYPASS VALVE 105 OPEN/CLOSE		X		
020010	STARTUP BYPASS VALVE 105 FEEDBACK	X			
020011	FC-1 BY-PASS VALVE 201 OPEN/CLOSE		X		
020012	FC-1 BY-PASS VALVE 201 FEEDBACK	X			
020013	WARM FLOOR VALVE 202 OPEN/CLOSE		X		
020014	WARM FLOOR VALVE 202 FEEDBACK	X			
020015	SNOW MELT RETURN VALVE 203 OPEN/CLOSE				X
020016	SNOW MELT RETURN VALVE 203 FEEDBACK			X	
020017	WATER IN VALVE 301 OPEN/CLOSE				X
020018	WATER IN VALVE 301 FEEDBACK			X	
020019	WATER DRAIN VALVE 302 OPEN/CLOSE				X
020020	WATER DRAIN VALVE 302 FEEDBACK			X	

IO-CONTROLLER 2 + EXPANSION					
POINT NUMBER	POINT DESCRIPTION	INTEGRATED HARDWARE			
		POINT TYPE			
		ANALOG INPUT	ANALOG OUTPUT	DIGITAL INPUT	DIGITAL OUTPUT
030001	ITP-1 EVAP. OUTLET PRESSURE	X			
030002	ITP-1 EVAP. INLET PRESSURE	X			
030003	ITP-1 COND. OUTLET PRESSURE	X			
030004	ITP-1 COND. INLET PRESSURE	X			
030005	ITP-2 EVAP. OUTLET PRESSURE	X			
030006	ITP-2 EVAP. INLET PRESSURE	X			
030007	ITP-2 COND. OUTLET PRESSURE	X			
030008	ITP-2 COND. INLET PRESSURE	X			
030009	ITP-3 EVAP. OUTLET PRESSURE	X			
030010	ITP-3 EVAP. INLET PRESSURE	X			
030011	ITP-3 COND. OUTLET PRESSURE	X			
030012	ITP-3 COND. INLET PRESSURE	X			
030013	ITP-4 EVAP. OUTLET PRESSURE	X			
030014	ITP-4 EVAP. INLET PRESSURE	X			
030015	ITP-4 COND. OUTLET PRESSURE	X			
030016	ITP-4 COND. INLET PRESSURE	X			
030017	COLD GLYCOL HEADER SUPPLY PRESSURE	X			
030018	COLD GLYCOL HEADER RETURN PRESSURE	X			
030019	COLD GLYCOL PUMP INLET PRESSURE	X			
030020	RINK FLOOR 1 SUPPLY PRESSURE	X			
030021	RINK FLOOR 2 SUPPLY PRESSURE	X			
030022	WARM GLYCOL HEADER SUPPLY PRESSURE	X			
030023	WARM GLYCOL HEADER RETURN PRESSURE	X			
030024	CONDENSER PUMP INLET PRESSURE	X			

IO-CONTROLLER 3 + EXPANSIONS					
POINT NUMBER	POINT DESCRIPTION	INTEGRATED HARDWARE			
		POINT TYPE			
		ANALOG INPUT	ANALOG OUTPUT	DIGITAL INPUT	DIGITAL OUTPUT
040001	COLD GLYCOL HEADER SUPPLY TEMPERATURE	X			
040002	RINK COLD FLOOR 1 RETURN TEMPERATURE	X			
040003	RINK COLD FLOOR 1 SUPPLY TEMPERATURE	X			
040004	RINK COLD FLOOR 1 SLAB TEMPERATURE	X			
040005	RINK COLD FLOOR 1 SLAB TEMPERATURE	X			
040006	RINK COLD FLOOR 1 SLAB TEMPERATURE	X			
040007	RINK COLD FLOOR 1 SLAB TEMPERATURE	X			
040008	RINK COLD FLOOR 1 SLAB TEMPERATURE	X			
040009	RINK COLD FLOOR 1 SLAB TEMPERATURE	X			
040010	RINK COLD FLOOR 2 RETURN TEMPERATURE	X			

CONT. IO-CONTROLLER 3 + EXPANSIONS					
POINT NUMBER	POINT DESCRIPTION	INTEGRATED HARDWARE			
		POINT TYPE			
		ANALOG INPUT	ANALOG OUTPUT	DIGITAL INPUT	DIGITAL OUTPUT
040011	RINK COLD FLOOR 2 SUPPLY TEMPERATURE	X			
040012	RINK COLD FLOOR 2 SLAB TEMPERATURE	X			
040013	RINK COLD FLOOR 2 SLAB TEMPERATURE	X			
040014	RINK COLD FLOOR 2 SLAB TEMPERATURE	X			
040015	RINK COLD FLOOR 2 SLAB TEMPERATURE	X			
040016	RINK COLD FLOOR 2 SLAB TEMPERATURE	X			
040017	RINK COLD FLOOR 2 SLAB TEMPERATURE	X			
040018	WARM GLYCOL HEADER SUPPLY TEMPERATURE	X			
040019	RINK WARM FLOOR 1 SUPPLY TEMPERATURE	X			
040020	RINK WARM FLOOR 1 RETURN TEMPERATURE	X			
040021	RINK WARM FLOOR 2 SUPPLY TEMPERATURE	X			
040022	RINK WARM FLOOR 2 RETURN TEMPERATURE	X			
040023	RINK WARM FLOOR 1 SLAB TEMPERATURE	X			
040024	RINK WARM FLOOR 2 SLAB TEMPERATURE	X			
040025	HYDRAULIC SEPARATOR RETURN TEMPERATURE	X			
040026	CONDENSER PUMP INLET TEMPERATURE	X			
040027	SNOW MELT PIT TEMPERATURE	X			
040028	SNOW MELT PIT RETURN TEMPERATURE	X			
040029	PLANT ROOM TEMPERATURE SENSOR	X			
040030	RINK WARM FLOOR 1 SLAB TEMPERATURE	X			
040031	RINK WARM FLOOR 2 SLAB TEMPERATURE	X			
040032	RINK 1 SPACE TEMPERATURE SENSOR 1	X			
040033	RINK 1 SPACE TEMPERATURE SENSOR 2	X			
040034	RINK 2 SPACE TEMPERATURE SENSOR 1	X			
040035	RINK 2 SPACE TEMPERATURE SENSOR 2	X			
040036	DP-1 CURRENT (AMPS)	X			

IO-CONTROLLER 4 + EXPANSIONS					
POINT NUMBER	POINT DESCRIPTION	INTEGRATED HARDWARE			
		POINT TYPE			
		ANALOG INPUT	ANALOG OUTPUT	DIGITAL INPUT	DIGITAL OUTPUT
050001	WFP-1 START/STOP				X
050002	WFP-1 FEEDBACK	X			
050003	WFP-2 START/STOP				X
050004	WFP-2 FEEDBACK	X			
050005	WFP-3 START/STOP				X
050006	WFP-3 FEEDBACK	X			
050007	COLD FLOOR 1 SUPPLY FLOWMETER	X			
050008	WARM GLYCOL HEADER RETURN FLOWMETER	X			
050009	PLANT ROOM HUMIDITY SENSOR	X			
050010	<RESERVED>				
050011	PLANT ROOM CO2 SENSOR	X			
050012	<RESERVED>				
050013	COLD FLOOR 2 SUPPLY FLOWMETER	X			
050014	SP-1 START/STOP				X
050015	SP-1 FEEDBACK	X			
050016	RINK 1 HUMIDITY SENSOR 1	X			
050017	RINK 1 HUMIDITY SENSOR 2	X			
050018	RINK 2 HUMIDITY SENSOR 1	X			
050019	RINK 2 HUMIDITY SENSOR 2	X			
050020	RINK 1 CO SENSOR 1	X			
050021	RINK 1 CO SENSOR 2	X			
050022	RINK 2 CO SENSOR 1	X			
050023	RINK 2 CO SENSOR 2	X			
050024	RINK 1 CO2 SENSOR 1	X			
050025	RINK 1 CO2 SENSOR 2	X			
050026	RINK 2 CO2 SENSOR 1	X			
050027	RINK 2 CO2 SENSOR 2	X			
050028	RELIEF REFRIGERANT ALARM	X			
050029	EF-3 START/STOP				X
050030	EF-3 STATUS			X	
050031	EF-A START/STOP				X
050032	EF-A STATUS			X	
050033	INTAKE LOUVER DAMPER OPEN/CLOSE				X
050034	INTAKE DAMPER FEEDBACK			X	

NOTES

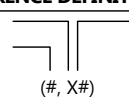
REFERENCE DEFINITION
 SHEET COLUMN SHEET NUMBER  SHEET ROW (#, X#)

COPYRIGHT AND DISCLAIMER
 THIS WORK IS THE SOLE PROPERTY OF I.B. STOREY INC AND IS INTENDED SOLELY FOR THE INFORMATION OF THE CLIENT. ALL RIGHTS RESERVED. THE WORK MAY NOT BE REPRODUCED OR DISTRIBUTED, WHOLE OR IN PART, WITHOUT THE PRIOR WRITTEN PERMISSION OF I.B. STOREY INC.
 THIS DOCUMENT MAY NOT BE USED FOR ANY OTHER PROJECTS OR WITHOUT INVOLVEMENT OF I.B. STOREY INC. ANY USE WHICH A THIRD PARTY MAKES OF THE WORK, OR ANY RELIANCE ON OR DECISIONS TO BE MADE BASED ON IT, ARE THE RESPONSIBILITY OF SUCH THIRD PARTIES.

- NOT FOR CONSTRUCTION -
CONFIDENTIAL & PROPRIETARY

2.0	ISSUED FOR DETAILED DESIGN	05-SEP-24	H.A.
1.0	ISSUED FOR SCHEMATIC DESIGN	28-JUN-24	H.A.
VER #	REVISIONS	DATE	BY

I.B. STOREY
 Rink Engineering Experts

CHARLOTTETOWN PE
 VAUGHAN ON
 REDINGTON SHORES FL
 PLANO TX

WWW.IBSTOREY.COM

STAMP

DRAWING NUMBER	24009 MI601
DRAWING NAME	AUTOMATION SCHEMATICS
CLIENT	SPRINGFIELD PARK DISTRICT
PROJECT	SPRINGFIELD - PLANT REPLACEMENT
DRAWN BY	H.AKAR
CHECKED BY	J.RITCHIE
DATE	05-SEP-24
REVISION	2.0
SHEET SIZE	C
SHEET NO.	6 OF 7

24009 MI601

CONTRACTOR NOTES

ALL CONTROL WIRING, ELECTRICAL WIRING, CONDUIT, STARTERS, DISCONNECT, BREAKERS, ETC. REQUIRED BY THE EQUIPMENT OF THIS DOCUMENT SHALL BE BY THIS CONTRACTOR.
 SUPPLY OF ALL FIELD SENSORS AND CONTROL DEVICES IS REQUIRED BY THE CONTRACTOR. INSTALLATION OF THE DEVICES IS TO BE DONE BY THE MECHANICAL CONTRACTOR IN COORDINATION WITH THIS CONTRACTOR
 CONTRACTOR IS RESPONSIBLE FOR THE SUPPLY OF ALL CONTROLLER PANELS AND OPERATOR TERMINALS INCLUDING ANY REQUIRED HARDWARE, SOFTWARE OR LICENSES
 CONTRACTOR IS RESPONSIBLE FOR ALL REQUIRED CONTROL PROGRAMMING AND DOCUMENTATION OF SAID PROGRAMMING
 AUTOMATION IS TO COORDINATE WITH THE OTHER TRADES IN THE BUILDING TO ENSURE PROPER ELECTRICAL SUPPLY TO THE AUTOMATION PANELS
 CONFORM TO ALL APPLICABLE STANDARDS AND THEIR AMENDMENTS INCLUDING BUT NOT LIMITED TO
 A. MANUFACTURER REQUIREMENTS
 B. NATIONAL BUILDING CODES
 C. LOCAL INSPECTION AUTHORITY SERVICE REGULATIONS,
 D. SUPPLY AUTHORITY SERVICE REGULATIONS,
 E. LOCAL MUNICIPAL BYLAWS
 OBTAIN NECESSARY PERMITS AND COVER COSTS OF SUCH PERMITS.
 SUBMIT DRAWINGS BY THIS CONTRACTOR TO ELECTRICAL INSPECTION AUTHORITY FOR APPROVAL PRIOR TO START OF WORK.
 IDENTIFY ELECTRICAL EQUIPMENT WITH 3MM THICK LAMACOID NAMEPLATES, BLACK FACE, WHITE CORE, MECHANICALLY ATTACHED: SIZE 25MM X 100MM, 2 LINES, 6MM HIGH LETTERS.
 EQUIPMENT SHALL BE SUITABLE FOR THE ENVIRONMENT IN WHICH IT IS INSTALLED; I.E. ADEQUATE PROTECTION WHEN REQUIRED.
 DISCONNECT SWITCHES TO BE HEAVY-DUTY RATED 4W. PROVISIONS FOR PAD LOCKING IN OFF POSITION BY TWO LOCKS.
 STARTERS TO HAVE RELAY OVERLOAD HEATERS SIZED TO SUIT THE LOAD BEING CONTROLLED. UNLESS OTHERWISE STATED, CONTROL VOLTAGE SHALL BE 24V. PROVIDE MANUAL DISCONNECT AND INDICATING PILOT LIGHTS ON EACH STARTER. PROVIDE H-0-A SWITCH ON EACH STARTER. STARTERS SHALL BE BREAKER TYPE.
 ALL CONTROLLED EQUIPMENT ARE TO HAVE HAND - OFF - AUTO SWITCHES TO ALLOW FOR MANUAL OPERATION IN CASES OF BAS FAILURE
 ALL VARIABLE SPEED DRIVES ARE TO HAVE BYPASS SO THEY CAN BE RUN IN THE EVENT OF DRIVE FAILURE
 ALTERNATE CONTROLLER ARCHITECTURE MAY BE PERMITTED, PROVIDED CONTROLLERS ARE APPROVED AS EQUIVALENT.

CONTROLLER SCHEDULE			
DEVICE	BRAND	MODEL	QUANTITY
BACNET / MODBUS RTU CONTROLLER	HONEYWELL	JACE-8000	1
IO CONTROLLER 1	HONEYWELL	IO-R-34	1
IO CONTROLLER 2	HONEYWELL	IO-R-34	1
> IO CONTROLLER 2 EXPANSION MODULES	HONEYWELL	IO-R-16	1
IO CONTROLLER 3	HONEYWELL	IO-R-34	1
> IO CONTROLLER 3 EXPANSION MODULES	HONEYWELL	IO-R-16	3
IO CONTROLLER 4	HONEYWELL	IO-R-34	1
> IO CONTROLLER 4 EXPANSION MODULES	HONEYWELL	IO-R-16	2

INSTRUMENTATION SCHEDULE			
DEVICE	BRAND	MODEL	QUANTITY
BACNET POWER METERS	HONEYWELL	E-MON CLASS 5000	2
BACNET VFDS FOR COLD FLOOR PUMPS	ABB	ACH580-01-046A-4	3
BACNET VFDS FOR HEAT REJECTION PUMPS	ABB	ACH580-01-039A-4	2
FLUID FLOW METERS	ONICON	F-1100-10-C3-1221	3
COLD SLAB TEMPERATURE SENSORS	HONEYWELL	T775-SENS-WT	12
WARM SLAB TEMPERATURE SENSORS	HONEYWELL	T775-SENS-WT	4
SNOW MELT PIT TEMPERATURE SENSOR	HONEYWELL	T775-SENS-WT	1
WALL TEMPERATURE & HUMIDITY SENSORS	HONEYWELL	H7635C2015	5
WALL CO2 SENSORS	GREYSTONE	CDD4A101	4
WALL CO SENSORS	GREYSTONE	CMD5B1000	4
IMMERSION PRESSURE SENSOR	HONEYWELL	MLH150PSM01B	24
IMMERSION TEMPERATURE SENSOR	HONEYWELL	C7041D2001	13
IMMERSION TEMPERATURE WELL	HONEYWELL	50001774-001	13
REFRIGERANT DETECTOR CONTROLLER	QEL	Q-CONTROLLERX-00	1
REFRIGERANT SENSOR	QEL	QIRF-513X-0	1
MANUAL FAN SWITCH	QEL	Q-SWITCH	2
RESET FAN SWITCH	QEL	R-SWITCH	1
RED STROBE & HORN COMBINATION	QEL	M-STROBE	2

AUTOMATION CONTRACTOR NOTES & SCHEDULE

NOTE:
 ALL AUTOMATION EQUIPMENT TO BE SUPPLIED BY
 AUTOMATION CONTRACTOR INSTALLED BY MECHANICAL CONTRACTOR

NOTES

REFERENCE DEFINITION	
SHEET COLUMN	SHEET ROW
SHEET NUMBER	(#, X#)

COPYRIGHT AND DISCLAIMER

THIS WORK IS THE SOLE PROPERTY OF I.B. STOREY INC AND IS INTENDED SOLELY FOR THE INFORMATION OF THE CLIENT. ALL RIGHTS RESERVED. THE WORK MAY NOT BE REPRODUCED OR DISTRIBUTED, WHOLE OR IN PART, WITHOUT THE PRIOR WRITTEN PERMISSION OF I.B. STOREY INC.
 THIS DOCUMENT MAY NOT BE USED FOR ANY OTHER PROJECTS OR WITHOUT INVOLVEMENT OF I.B. STOREY INC. ANY USE WHICH A THIRD PARTY MAKES OF THE WORK, OR ANY RELIANCE ON OR DECISIONS TO BE MADE BASED ON IT, ARE THE RESPONSIBILITY OF SUCH THIRD PARTIES.

- NOT FOR CONSTRUCTION -
CONFIDENTIAL & PROPRIETARY

VER #	REVISIONS	DATE	BY
2.0	ISSUED FOR DETAILED DESIGN	05-SEP-24	H.A.
1.0	ISSUED FOR SCHEMATIC DESIGN	28-JUN-24	H.A.



CHARLOTTETOWN PE
 VAUGHAN ON
 REDINGTON SHORES FL
 PLANO TX

WWW.IBSTOREY.COM

STAMP	
DRAWING NUMBER	24009 MI601
DRAWING NAME	AUTOMATION SCHEMATICS
CLIENT	SPRINGFIELD PARK DISTRICT
PROJECT	SPRINGFIELD - PLANT REPLACEMENT
DRAWN BY	H.AKAR
CHECKED BY	J.RITCHIE
DATE	05-SEP-24
REVISION	2.0
SHEET SIZE	C
SHEET NO.	7 OF 7

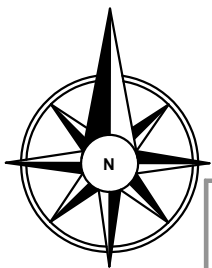

SITE KEY

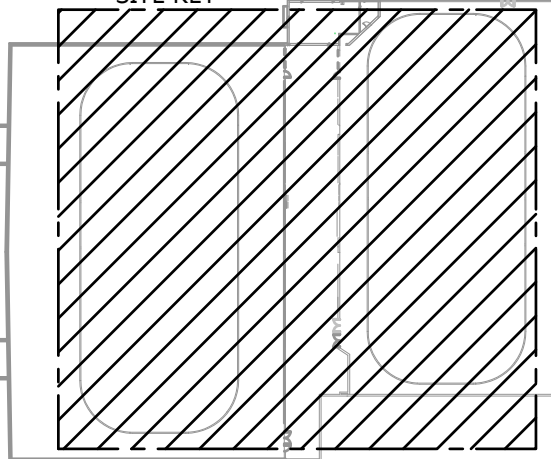

NOTE:

- RINKS 1 AND 2 EXCAVATION BOUNDS ARE 201'-2" X 86'-2".
- THE TOTAL EXCAVATION DEPTH IS 16".
- A GRANULAR SUB-BASE LAYER MUST BE BELOW THE EXCAVATED SPACE.
- ALL MEASUREMENTS ARE APPROXIMATE AND ARE TO BE CONFIRMED ON SITE.
- CONTRACTOR TO CONFIRM EXISTING PLUMBING PIPING PATH TO AVOID PIPING CONFLICT.
- THE PIPING INSULATION THICKNESS IS 1".
- PIPING INSTALLED IN PUBLIC SPACES SHALL BE LOCATED INSIDE A METALLIC MESH CAGE TO PREVENT DAMAGE AND UNAUTHORIZED ACCESS.

NOTES

---	NEW
---	EXISTING

REFERENCE DEFINITION	
SHEET COLUMN	SHEET ROW
SHEET NUMBER	(#, X#)

COPYRIGHT AND DISCLAIMER
 THIS WORK IS THE SOLE PROPERTY OF I.B. STOREY INC AND IS INTENDED SOLELY FOR THE INFORMATION OF THE CLIENT. ALL RIGHTS RESERVED. THE WORK MAY NOT BE REPRODUCED OR DISTRIBUTED, WHOLE OR IN PART, WITHOUT THE PRIOR WRITTEN PERMISSION OF I.B. STOREY INC.
 THIS DOCUMENT MAY NOT BE USED FOR ANY OTHER PROJECTS OR WITHOUT INVOLVEMENT OF I.B. STOREY INC. ANY USE WHICH A THIRD PARTY MAKES OF THE WORK, OR ANY RELIANCE ON OR DECISIONS TO BE MADE BASED ON IT, ARE THE RESPONSIBILITY OF SUCH THIRD PARTIES.

- NOT FOR CONSTRUCTION -
CONFIDENTIAL & PROPRIETARY

VER #	REVISIONS	DATE	BY
2.0	ISSUED FOR DETAILED DESIGN	05-SEP-24	V.K.
1.0	ISSUED FOR SCHEMATIC DESIGN	28-JUN-24	V.K.



CHARLOTTETOWN PE
 VAUGHAN ON
 REDINGTON SHORES FL
 PLANO TX

WWW.IBSTOREY.COM

STAMP

DRAWING NUMBER 24009 MR101	
DRAWING NAME RINK FLOOR LAYOUT	
CLIENT SPRINGFIELD PARK DISTRICT	
PROJECT SPRINGFIELD - PLANT REPLACEMENT	
DRAWN BY V.KOFANOV	CHECKED BY J. RITCHIE
DATE 05-SEP-24	REVISION 2.0
SHEET SIZE C	SHEET NO. 1 OF 1

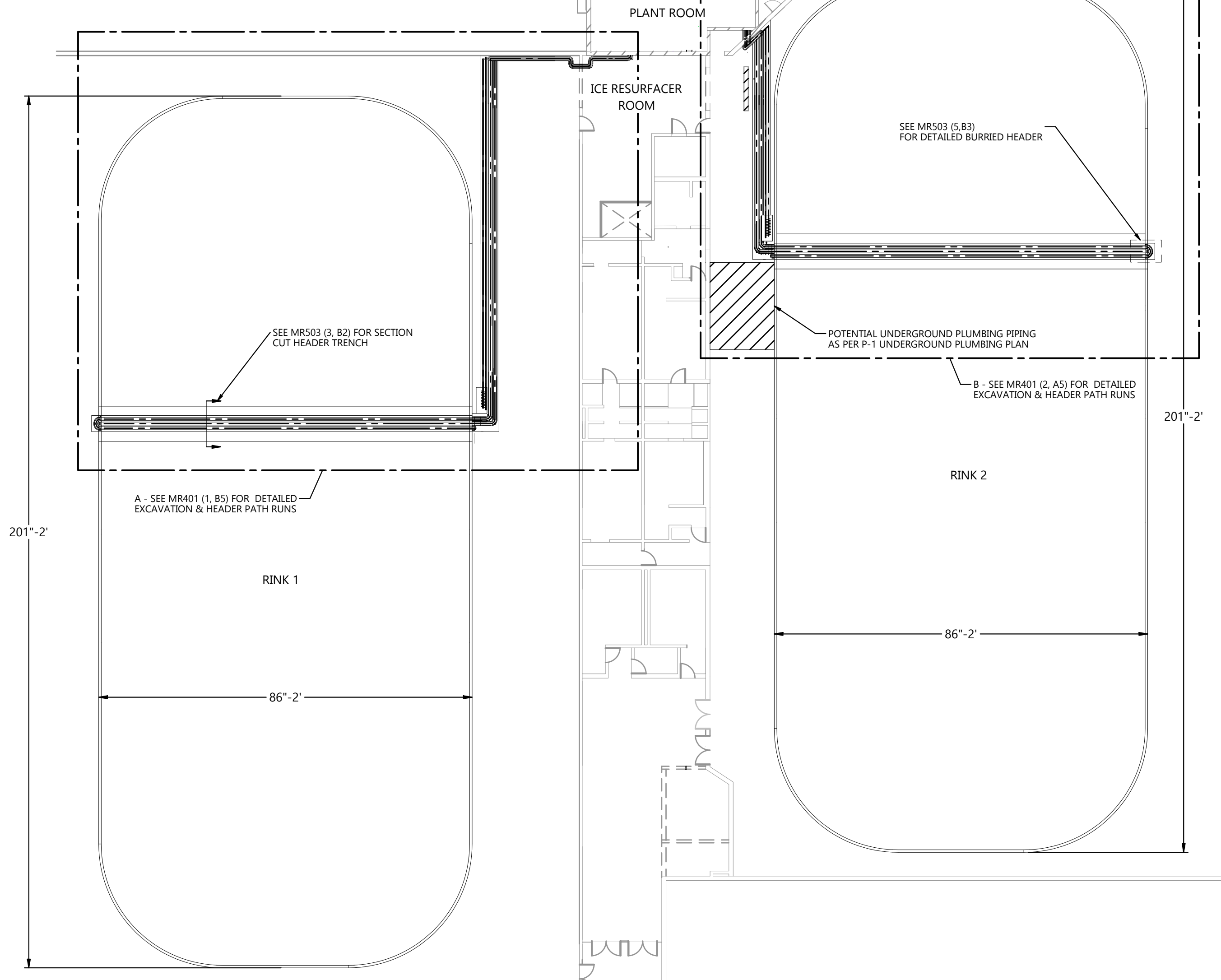

RINK EXCAVATION BOUNDS
 SCALE 1"=20'

24009 MR101

1

2

3

4

5

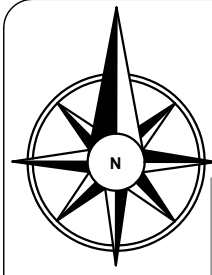

SITE KEY

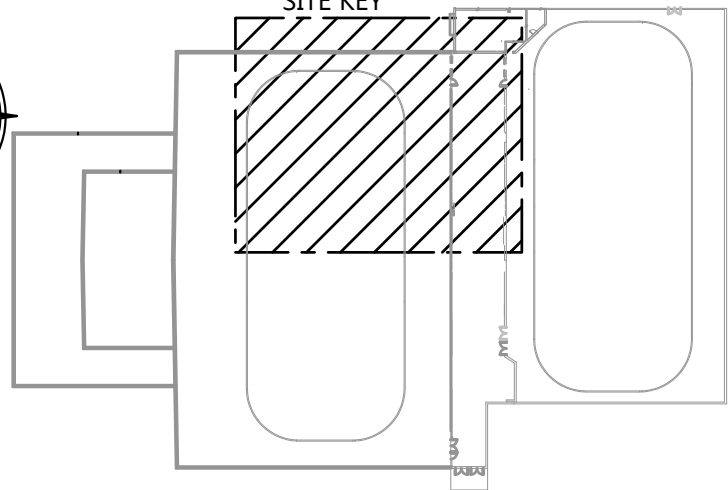

NOTE:

- ALL MEASUREMENTS ARE APPROXIMATE AND ARE TO BE CONFIRMED ON SITE.
- CONTRACTOR TO CONFIRM EXISTING PLUMBING PIPING PATH TO AVOID PIPING CONFLICT.
- THE PIPING INSULATION THICKNESS IS 1".
- PIPING INSTALLED IN PUBLIC SPACES SHALL BE LOCATED INSIDE A METALLIC MESH CAGE TO PREVENT DAMAGE AND UNAUTHORIZED ACCESS.

NOTES

---	NEW
---	EXISTING

REFERENCE DEFINITION	
SHEET COLUMN	SHEET ROW
SHEET NUMBER	(#, X#)

COPYRIGHT AND DISCLAIMER

THIS WORK IS THE SOLE PROPERTY OF I.B. STOREY INC AND IS INTENDED SOLELY FOR THE INFORMATION OF THE CLIENT. ALL RIGHTS RESERVED. THE WORK MAY NOT BE REPRODUCED OR DISTRIBUTED, WHOLE OR IN PART, WITHOUT THE PRIOR WRITTEN PERMISSION OF I.B. STOREY INC. THIS DOCUMENT MAY NOT BE USED FOR ANY OTHER PROJECTS OR WITHOUT INVOLVEMENT OF I.B. STOREY INC. ANY USE WHICH A THIRD PARTY MAKES OF THE WORK, OR ANY RELIANCE ON OR DECISIONS TO BE MADE BASED ON IT, ARE THE RESPONSIBILITY OF SUCH THIRD PARTIES.

- NOT FOR CONSTRUCTION -
CONFIDENTIAL & PROPRIETARY

2.0	ISSUED FOR DETAILED DESIGN	05-SEP-24	V.K.
1.0	ISSUED FOR SCHEMATIC DESIGN	28-JUN-24	V.K.
VER #	REVISIONS	DATE	BY



CHARLOTTETOWN PE
VAUGHAN ON
REDINGTON SHORES FL
PLANO TX

WWW.IBSTOREY.COM

STAMP			
DRAWING NUMBER 24009 MR401			
DRAWING NAME RINK FLOOR LARGE-SCALE VIEWS			
CLIENT SPRINGFIELD PARK DISTRICT			
PROJECT SPRINGFIELD - PLANT REPLACEMENT			
DRAWN BY V.KOFANOV		CHECKED BY J. RITCHIE	
DATE 05-SEP-24		REVISION 2.0	
SHEET SIZE C		SHEET NO. 1 OF 3	

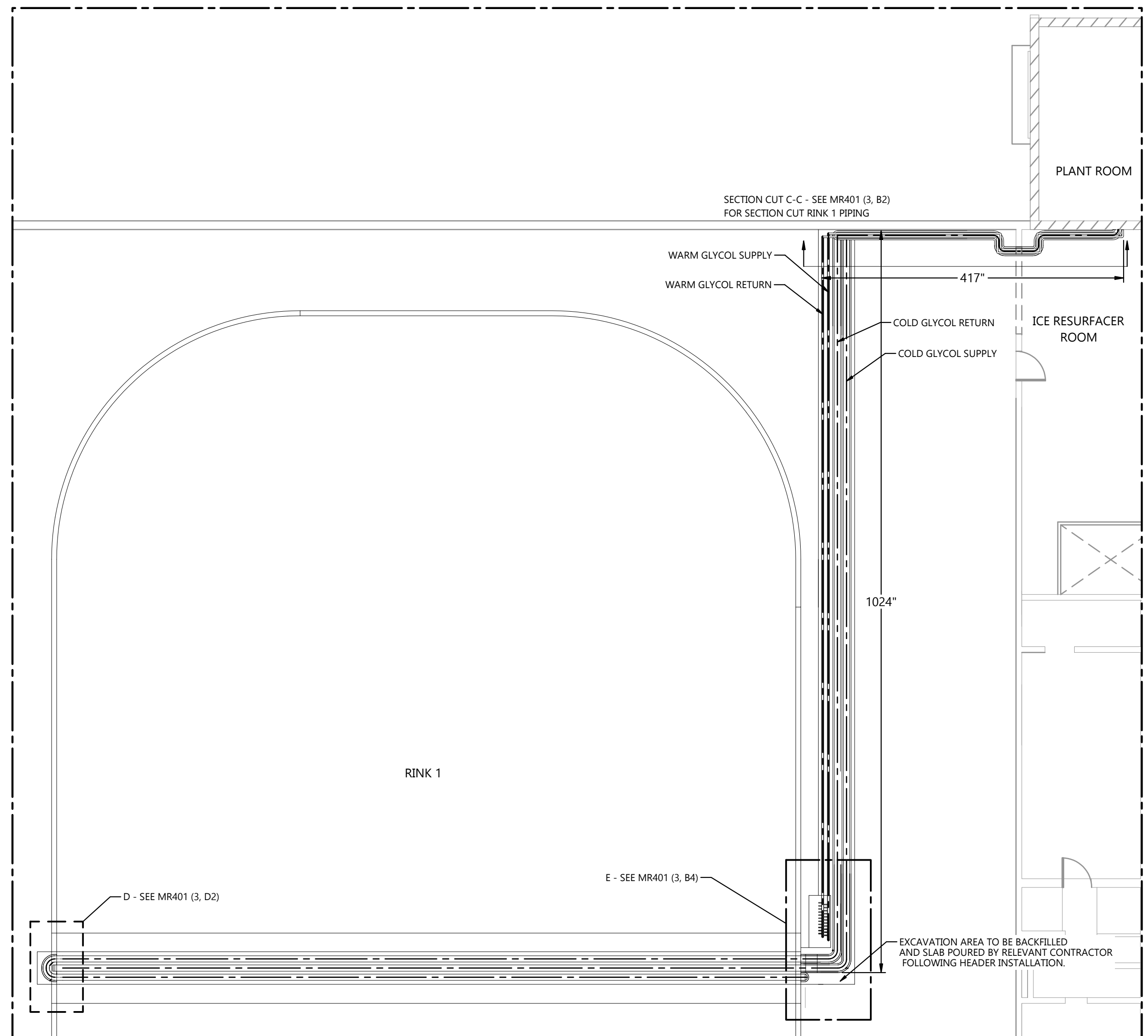

DETAIL A (MR101, 1, B3) EXCAVATION & HEADER PATH RUNS

SCALE 1"=10'

24009 MR401

1

2

3

4

5

A

B

C

D

E

A

B

C

D

E

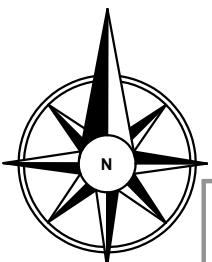

SITE KEY

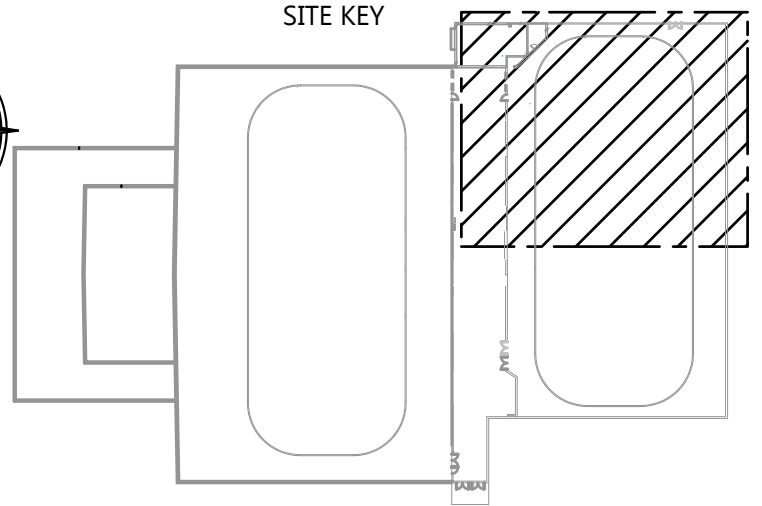

- NOTE:**
- ALL MEASUREMENTS ARE APPROXIMATE AND ARE TO BE CONFIRMED ON SITE.
 - CONTRACTOR TO CONFIRM EXISTING PLUMBING PIPING PATH TO AVOID PIPING CONFLICT.
 - THE PIPING INSULATION THICKNESS IS 1".
 - PIPING INSTALLED IN PUBLIC SPACES SHALL BE LOCATED INSIDE A METALLIC MESH CAGE TO PREVENT DAMAGE AND UNAUTHORIZED ACCESS.

NOTES

---	NEW
---	EXISTING

REFERENCE DEFINITION

SHEET COLUMN		SHEET ROW
SHEET NUMBER		(#, X#)

COPYRIGHT AND DISCLAIMER
 THIS WORK IS THE SOLE PROPERTY OF I.B. STOREY INC AND IS INTENDED SOLELY FOR THE INFORMATION OF THE CLIENT. ALL RIGHTS RESERVED. THE WORK MAY NOT BE REPRODUCED OR DISTRIBUTED, WHOLE OR IN PART, WITHOUT THE PRIOR WRITTEN PERMISSION OF I.B. STOREY INC.
 THIS DOCUMENT MAY NOT BE USED FOR ANY OTHER PROJECTS OR WITHOUT INVOLVEMENT OF I.B. STOREY INC. ANY USE WHICH A THIRD PARTY MAKES OF THE WORK, OR ANY RELIANCE ON OR DECISIONS TO BE MADE BASED ON IT, ARE THE RESPONSIBILITY OF SUCH THIRD PARTIES.

- NOT FOR CONSTRUCTION -
CONFIDENTIAL & PROPRIETARY

VER #	REVISIONS	DATE	BY
2.0	ISSUED FOR DETAILED DESIGN	05-SEP-24	V.K.
1.0	ISSUED FOR SCHEMATIC DESIGN	28-JUN-24	V.K.



CHARLOTTETOWN PE
 VAUGHAN ON
 REDINGTON SHORES FL
 PLANO TX

WWW.IBSTOREY.COM

STAMP

DRAWING NUMBER	
24009 MR401	
DRAWING NAME	
RINK FLOOR LARGE-SCALE VIEWS	
CLIENT	
SPRINGFIELD PARK DISTRICT	
PROJECT	
SPRINGFIELD - PLANT REPLACEMENT	
DRAWN BY	CHECKED BY
V.KOFANOV	J. RITCHIE
DATE	REVISION
05-SEP-24	2.0
SHEET SIZE	SHEET NO.
C	2 OF 3

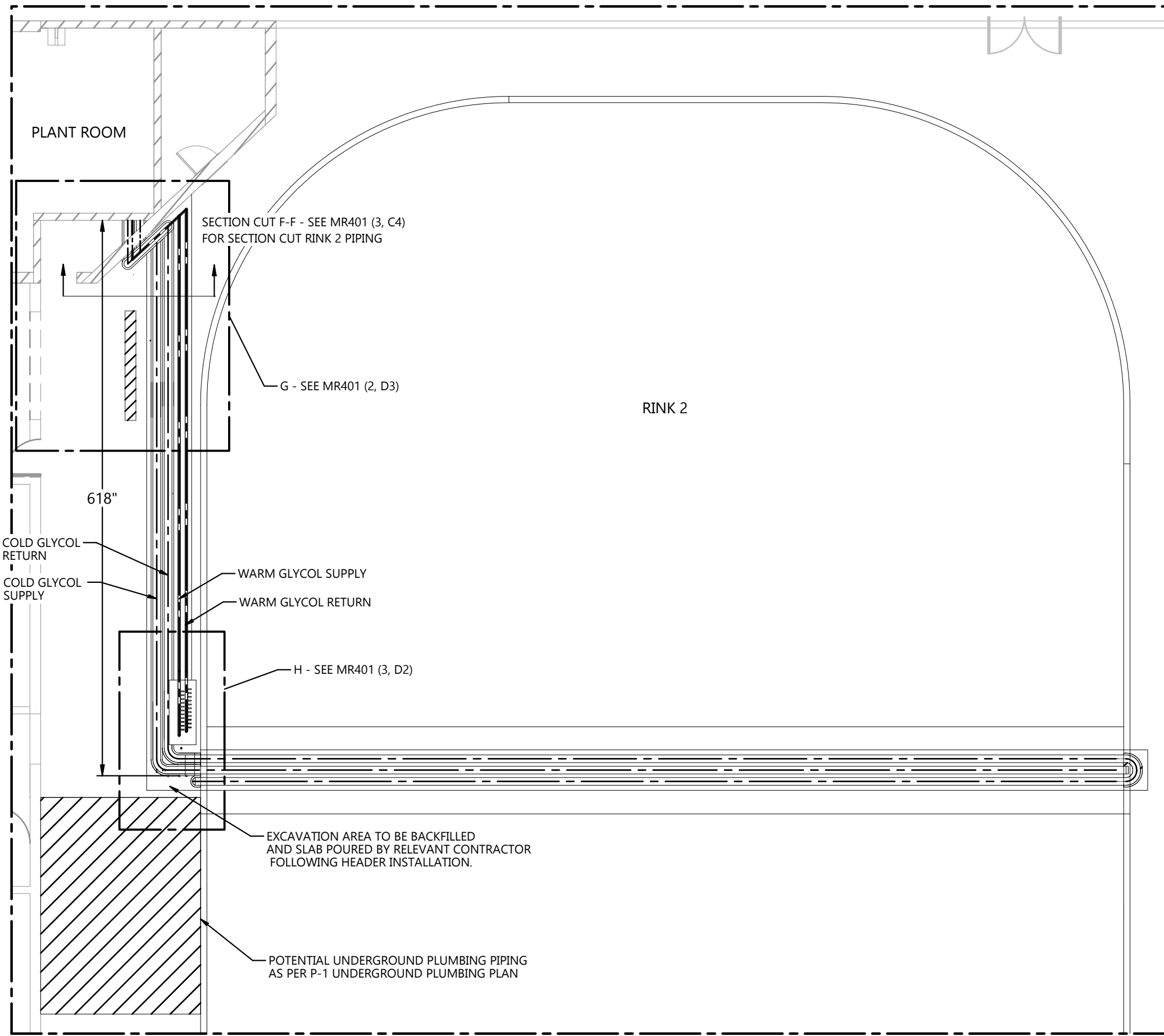

DETAIL B (MR101, 1, C3) EXCAVATION & HEADER PATH RUNS
 SCALE 1"=10'

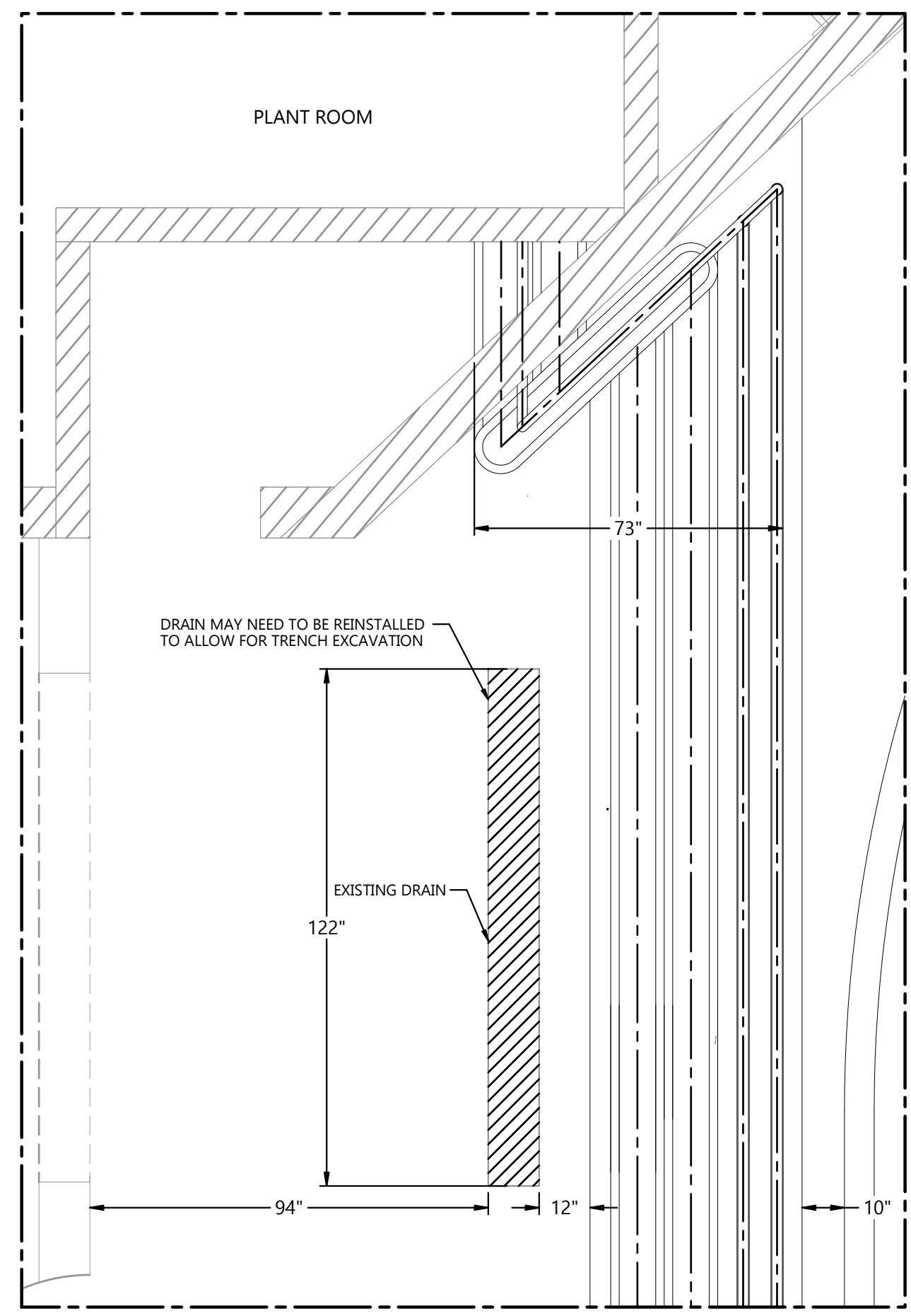

DETAIL G (MR101, 2, A3) EXCAVATION & HEADER PATH RUNS
 SCALE 3/8"=1'-0"

24009 MR401

1

2

3

4

5

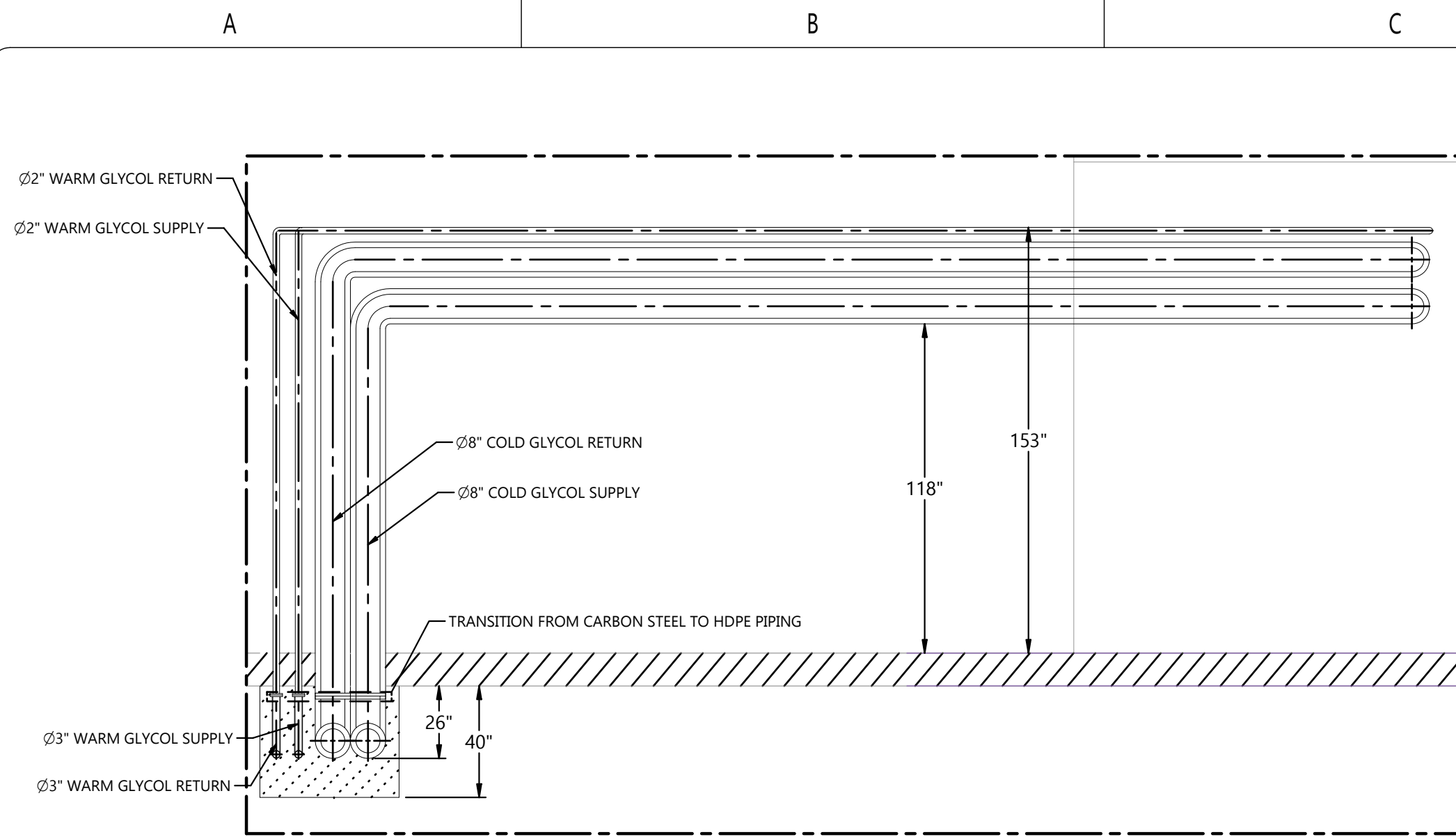

SECTION CUT C-C (MR401, 1, D2): RINK 1 PIPING
SCALE 1/4"=1'-0"

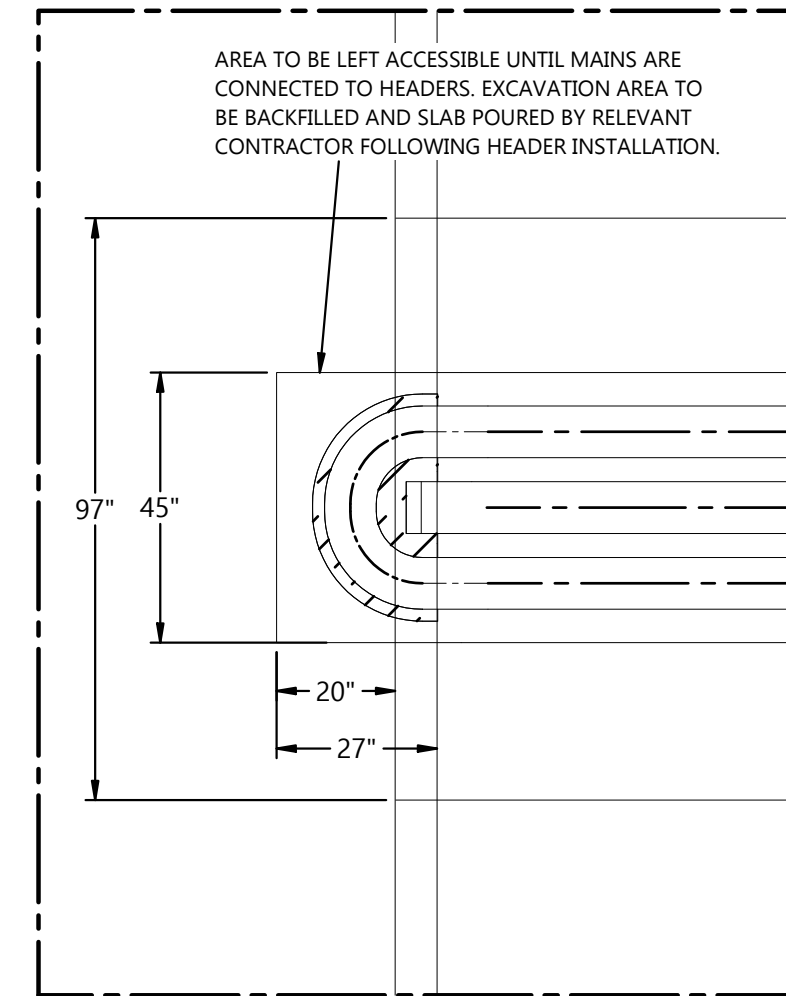

DETAIL D (MR401, 1, A5)
SCALE 3/8"=1'-0"

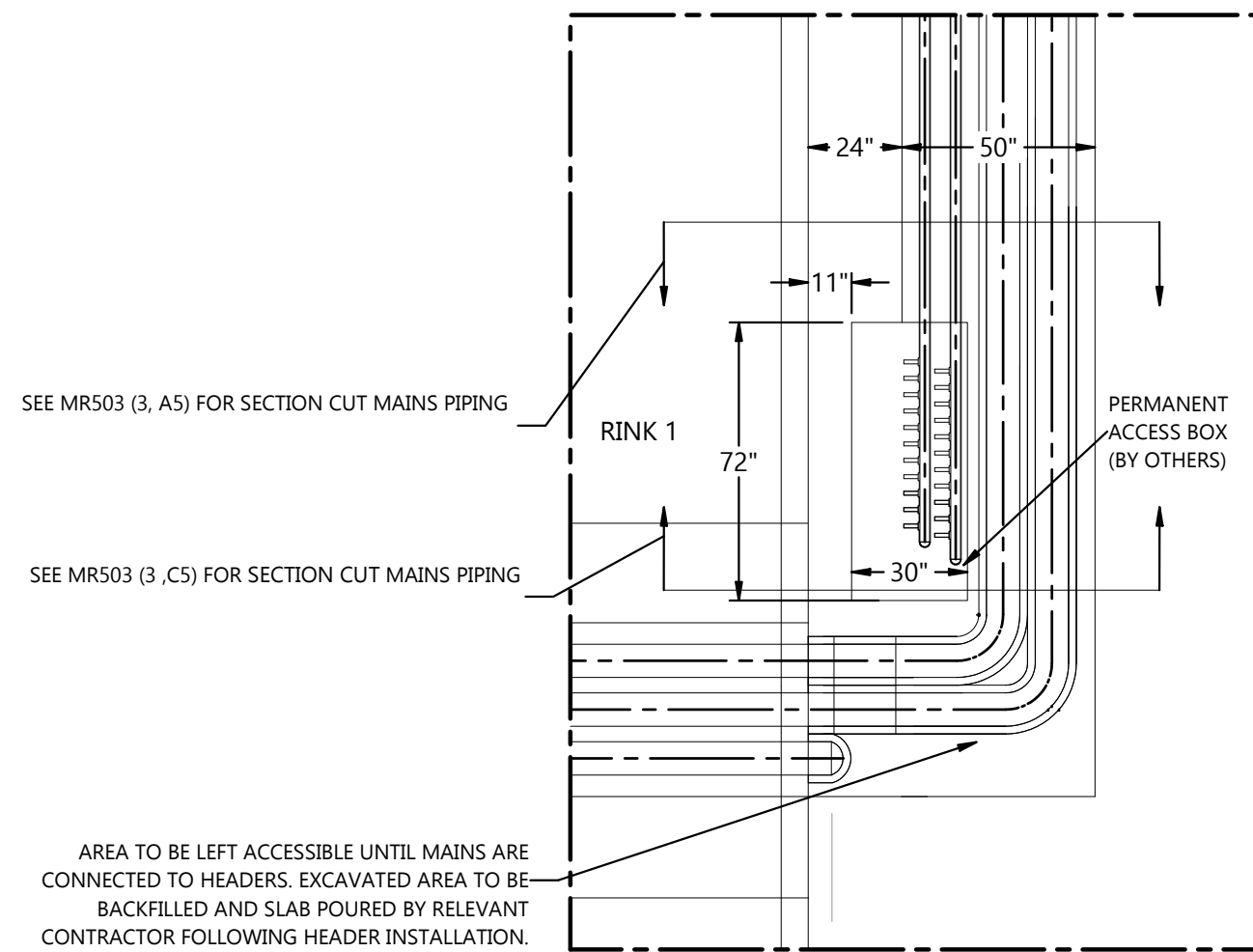

DETAIL E (MR401, 1, D5)
SCALE 1/4"=1'-0"

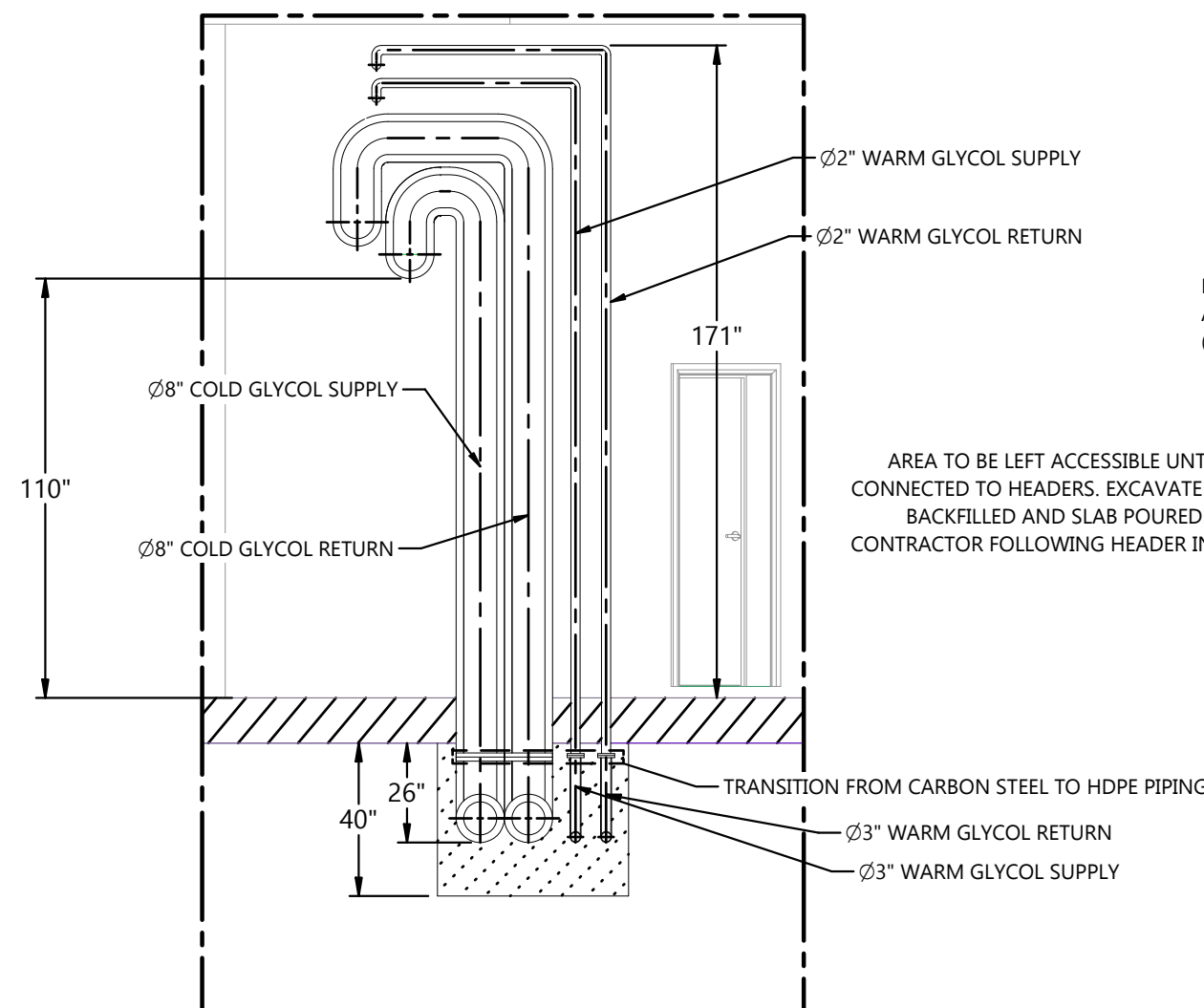

SECTION CUT F-F (MR401, 2, A3): RINK 2 PIPING
SCALE 1/4"=1'-0"

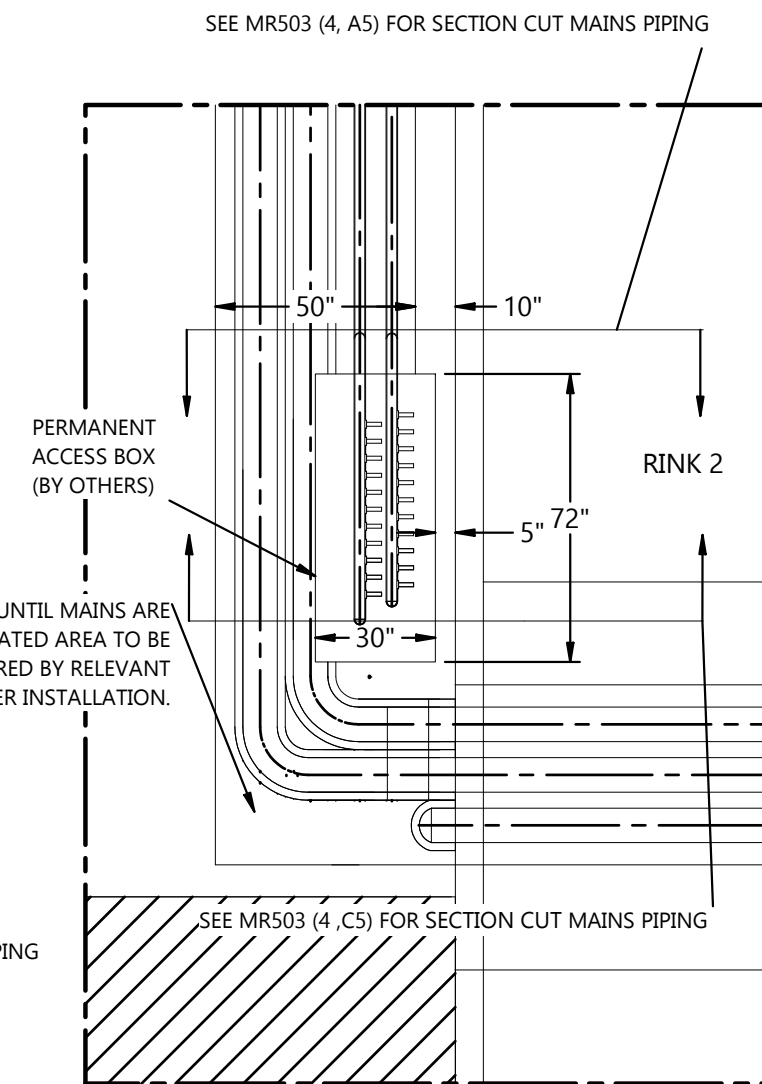

DETAIL H (MR401, 2, D4)
SCALE 1/4"=1'-0"

NOTES

---	NEW
---	EXISTING

REFERENCE DEFINITION	
SHEET COLUMN	SHEET ROW
SHEET NUMBER	(#, X#)

COPYRIGHT AND DISCLAIMER
THIS WORK IS THE SOLE PROPERTY OF I.B. STOREY INC AND IS INTENDED SOLELY FOR THE INFORMATION OF THE CLIENT. ALL RIGHTS RESERVED. THE WORK MAY NOT BE REPRODUCED OR DISTRIBUTED, WHOLE OR IN PART, WITHOUT THE PRIOR WRITTEN PERMISSION OF I.B. STOREY INC. THIS DOCUMENT MAY NOT BE USED FOR ANY OTHER PROJECTS OR WITHOUT INVOLVEMENT OF I.B. STOREY INC. ANY USE WHICH A THIRD PARTY MAKES OF THE WORK, OR ANY RELIANCE ON OR DECISIONS TO BE MADE BASED ON IT, ARE THE RESPONSIBILITY OF SUCH THIRD PARTIES.

- NOT FOR CONSTRUCTION -
CONFIDENTIAL & PROPRIETARY

2.0	ISSUED FOR DETAILED DESIGN	05-SEP-24	V.K.
1.0	ISSUED FOR SCHEMATIC DESIGN	28-JUN-24	V.K.
VER #	REVISIONS	DATE	BY



CHARLOTTETOWN PE
VAUGHAN ON
REDINGTON SHORES FL
PLANO TX

WWW.IBSTOREY.COM

STAMP	
DRAWING NUMBER 24009 MR401	
DRAWING NAME RINK FLOOR LARGE-SCALE VIEWS	
CLIENT SPRINGFIELD PARK DISTRICT	
PROJECT SPRINGFIELD - PLANT REPLACEMENT	
DRAWN BY V.KOFANOV	CHECKED BY J. RITCHIE
DATE 05-SEP-24	REVISION 2.0
SHEET SIZE C	SHEET NO. 3 OF 3

24009 MR401

1

2

3

4

5

NOTES

---	NEW
---	EXISTING

NOTES:

- PIPING, REBAR, AND MESH REMOVED FOR CLARITY.

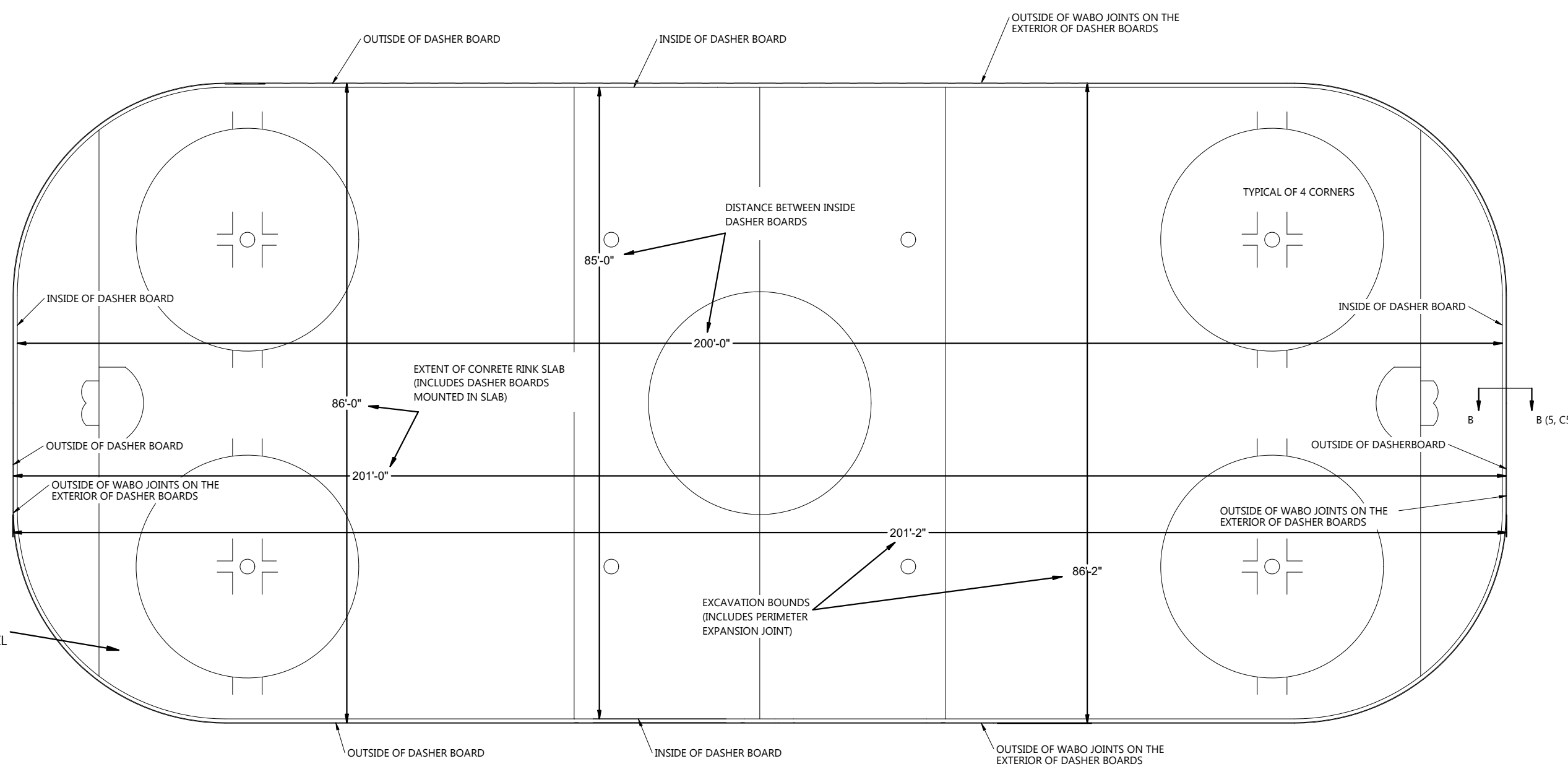

DETAIL A: RINK FLOOR DETAIL

SCALE 1/16"=1'-0"

CONCRETE QUALITY ASSURANCE TESTS			
TEST	FREQUENCY	NO. OF REPITIONS	NOTE(S)
SLUMP	PER TRUCKLOAD	3 - SUCCESSFUL	ALL THREE TESTS MUST BE SUCCESSFUL
AIR CONTENT	PER TRUCKLOAD	3 - SUCCESSFUL	AT THE POINT OF DEPOSITION
COMPRESSION	PER 50 CUYD.	SET OF FOUR CYLINDERS PER SAMPLING FOR 7, 14, 21, AND 28-DAY INTERVAL	DEPENDANT ON AMOUNT OF CONCRETE USED DURING THE FLOOR POUR

RINK FLOOR CONSTRUCTION:

- 1 FINISHED ICE SLAB SURFACE TO BE FLUSH WITH PERIMETER SURFACE.
- 2 INSULATE COLD FLOOR SUPPLY AND RETURN MAINS BETWEEN MECHANICAL ROOM CONNECTION AND BURIED HEADERS WITH 1" FOAMGLASS INSULATION AND PROTECTIVE WRAP.
- 3 INSTALL FLOOR INSULATION AFTER COMPLETION OF THE SUB-SOIL. INSULATION PROPERLY LEVELLED +/- 3/16" OVERLAPPED WITH STAGGERED JOINTS.
- 4 INSTALL SLIP SHEET ON TOP OF FLOOR INSULATION, OVERLAP EDGES 12".
- 5 ON NO ACCOUNT SHALL ANY REINFORCING RODS & EDGES OF MESH LIE IMMEDIATELY ABOVE OR BELOW PIPES TO AVOID PIPE PUNCTURE.
- 6 ALL JOINTS TO BE COMPLETELY FUSION WELDED.

FLOOR SLAB TOLERANCE:

- 1 COLD SLAB TOLERANCE MUST BE MEASURED USING F-NUMBER SYSTEM.
- 2 CLASSIFICATION D, EXTREMELY FLAT
- 3 FLOOR FLATNESS (FF) AND FLOOR LEVELNESS (FL) TO BE MEASURED IN ACCORDANCE WITH ASTM E1155M
- 4 SPECIFIED OVERALL VALUES (SOV)
 - 1 FLATNESS: FF 45
 - 2 LEVELNESS: FL 35
- 5 MINIMUM LOCAL VALUES (MLV)
 - 1 FLATNESS: FF 30
 - 2 LEVELNESS: FL 25
- 6 INSPECTION AND FLOOR TOLERANCE MEASUREMENTS SHALL BE MADE WITHIN 72 HOURS OF COMPLETING FLOOR SLAB. THE CONTRACTOR OF THIS SCOPE IS RESPONSIBLE FOR ALL TESTING REQUIREMENTS TO DEMONSTRATE TO THE OWNER'S ENGINEER THAT THE FLOOR FLATNESS AND LEVELNESS MEETS THESE SPECIFICATIONS IN REFERENCE TO ASTM E1155M.
 - 1 USE A D-METER OR APPROVED EQUIVALENT FOR ALL MEASUREMENTS ON FLOOR FLATNESS AND LEVELNESS. PROVIDE RESULTS IN A REPORT TO THE OWNER'S ENGINEER.
 - 2 NOTE THAT ASTM E1155M, PART 8 PROCEDURE, LAYS OUT THE STEPS THE CONTRACTOR MUST TAKE FOR COMPLIANT MEASUREMENTS INCLUDING GRIDING THE FLOOR AREA IN 300 MM SECTIONS.
- 7 SPECIFIED FLOOR TOLERANCES THAT FALL BELOW THE MLV SHALL BE CORRECTED BY GRINDING. ANY WORK OF THIS NATURE MUST BE APPROVED BY THE OWNER'S ENGINEER PRIOR TO COMMENCEMENT.

MATERIAL PROPERTIES:

- 1 STRENGTH: 32 MPA AT 28 DAYS. MINIMUM AVERAGE OF STRENGTH TEST MUST EXCEED SPECIFIED STRENGTH.
 - 1 PROVIDE CERTIFICATION THAT MIX PROPORTIONS SELECTED WILL PRODUCE CONCRETE OF SPECIFIED QUALITY AND YIELD STRENGTH WILL COMPLY WITH CAN3-A23.1.
- 2 AIR CONTENT: MAXIMUM OF 2% NON-ENTRAINED AIR.
- 3 MAXIMUM WATER TO CEMENTITIOUS MATERIAL (W/CM): 0.45
- 4 FLY ASH:
 - 1 SUPPLEMENTARY CEMENTING MATERIALS (SCM): MAXIMUM 15% TOTAL CEMENTITIOUS CONTENT.
 - 2 TYPE C OR F.
 - 3 LOSS OF IGNITION (LOI) NOT TO EXCEED 1%
 - 4 USE FLY ASH FROM ONE SOURCE.
- 5 MAXIMUM AGGREGATE: 14 MM GRADED AS PER CSA A23.1 GROUP 1 14-5
- 6 WATER REDUCING AND HIGH RANGE WATER REDUCING (SUPERPLASTICIZER) ADMIXTURES SHALL BE INCLUDED IN CONCRETE MIX IN COMPLIANCE WITH CSA A23.5 AS REQUIRED TO MAINTAIN MAX W/CM RATIO WHILE ENSURING REQUIRED FLOWABILITY.
- 7 INCLUDE A SHRINK-REDUCING ADMIXTURE
 - 1 MUST REDUCE CAPILLARY TENSION OF PORE WATER IN CEMENTITIOUS MIXTURES.
 - 2 PROVIDE MODERATE TO SIGNIFICANT REDUCTIONS IN THE DRYING SHRINKAGE OF CEMENTITIOUS MIXTURES.
 - 3 REDUCE STRESSES INDUCED FROM ONE-DIMENSIONAL SURFACE DRYING IN CONCRETE SLABS.
 - 4 MUST BE MIXED AT THE FACTORY. MIXING ON-SITE WILL NOT BE PERMITTED.
 - 5 STANDARD OF ACCEPTANCE: MASTERLIFE SRA-035, OR APPROVED EQUIVALENT.
- 8 SLUMP RANGE BEFORE PLASTICIZER: 70 MM ± 20 MM.
- 9 SLUMP RANGE AT DISCHARGE: 130 MM ± 30 MM.
- 10 USE APPROVED SET RETARDING ADMIXTURE AT THE MANUFACTURERS REQUIRED DOSAGE WHEN CONCRETE IS PLACED AT AMBIENT TEMPERATURE ABOVE 30°C (86°F).
- 11 USE APPROVED ACCELERATING ADMIXTURE AT THE MANUFACTURERS REQUIRED DOSAGE WHEN CONCRETE IS PLACED IN AMBIENT TEMPERATURES BELOW 10°C (50°F).
- 12 CALCIUM CHLORIDE ADMIXTURES ARE NOT PERMITTED FOR USE.

REFERENCE DEFINITION	
SHEET COLUMN	SHEET ROW
(#, X#)	

COPYRIGHT AND DISCLAIMER

THIS WORK IS THE SOLE PROPERTY OF I.B. STOREY INC AND IS INTENDED SOLELY FOR THE INFORMATION OF THE CLIENT. ALL RIGHTS RESERVED. THE WORK MAY NOT BE REPRODUCED OR DISTRIBUTED, WHOLE OR IN PART, WITHOUT THE PRIOR WRITTEN PERMISSION OF I.B. STOREY INC. THIS DOCUMENT MAY NOT BE USED FOR ANY OTHER PROJECTS OR WITHOUT INVOLVEMENT OF I.B. STOREY INC. ANY USE WHICH A THIRD PARTY MAKES OF THE WORK, OR ANY RELIANCE ON OR DECISIONS TO BE MADE BASED ON IT, ARE THE RESPONSIBILITY OF SUCH THIRD PARTIES.

- NOT FOR CONSTRUCTION -
CONFIDENTIAL & PROPRIETARY

VER #	REVISIONS	DATE	BY
4.0	ISSUED FOR DETAILED DESIGN	05-SEP-24	V.K.
3.0	ISSUED FOR SCHEMATIC DESIGN	28-JUN-24	V.K.
2.0	ISSUED FOR CONCEPTUAL DESIGN	29-MAY-24	E.K.
1.0	ISSUED FOR WORKSHOP	06-MAY-24	V.K.



CHARLOTTETOWN PE
VAUGHAN ON
REDINGTON SHORES FL
PLANO TX

WWW.IBSTOREY.COM

STAMP	

DRAWING NUMBER	
24009 MR503	
DRAWING NAME	
RINK FLOOR DETAILS	
CLIENT	
SPRINGFIELD PARK DISTRICT	
PROJECT	
SPRINGFIELD - PLANT REPLACEMENT	
DRAWN BY	CHECKED BY
V.KOFANOV	J. RITCHIE
DATE	REVISION
05-SEP-24	4.0
SHEET SIZE	SHEET NO.
C	1 OF 10

1

2

3

4

5

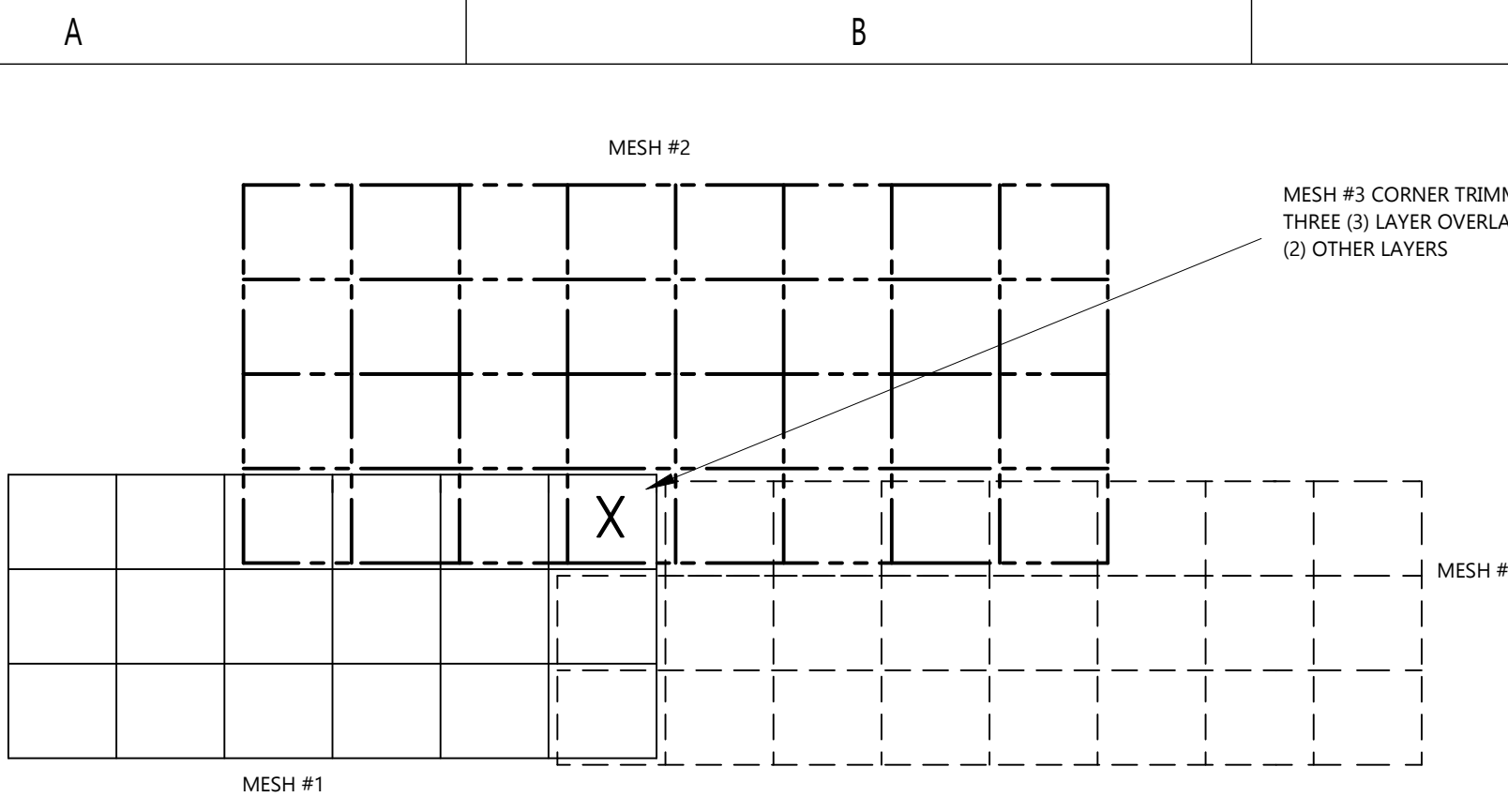

DETAIL C: WIRE MESH DETAIL
NTS

TOP LAYER REINFORCING WIRE MESH:

1. TO BE INSTALLED ON TOP OF RINK PIPING.
2. 6X6X6 (INCHES, INCHES, & GAUGE) WELDED WIRE MESH PLACED ON TOP OF RINK PIPING SUPPORTS (CHAIRS) ACROSS WHOLE AREA OF RINK SLAB.
3. ANY CUT PORTIONS MUST BE SECURED. 6X6 GRID REINFORCED STRUCTURE MUST BE MAINTAINED.
4. TOP REINFORCING MUST BE LAID AND LAPPED TO NOT EXCEED TWO (2) LAYERS, AND SECURELY TIED TO PIPE CHAIR SUPPORTS USING TIE WIRES.
 1. WIRES MUST HAVE LOOSE ENDS CUT AND BE TURNED AWAY FROM AND NOT ON TOP OF PIPING TO AVOID DAMAGE.
 2. TIE MESH TO PIPE CHAIRS A MINIMUM OF EVERY 12" ALONG THE PIPE CHAIRS AND AROUND THE PERIMETER OF EACH MESH SHEET.
 3. OVERLAPS MUST BE TIED TOGETHER WITH LOOP-TYPE WIRES AT A MINIMUM OF 12" SPACES IN TWO DIRECTIONS.
5. INSTALL CONTINUOUS WIRE MESH ABOVE THE RINK PIPES WITH 6" OVERLAPS. TIE OVERLAPS AS NOTED ABOVE.
6. TRIMMED CORNERS TO MAINTAIN TWO (2) LAYERS OVERLAP MAX.
7. USE FLAT SHEETS ONLY. ROLLED WILL NOT BE APPROVED.
8. UNDER NO CIRCUMSTANCES SHALL WIRE MESH BE TIED TO THE REBAR.

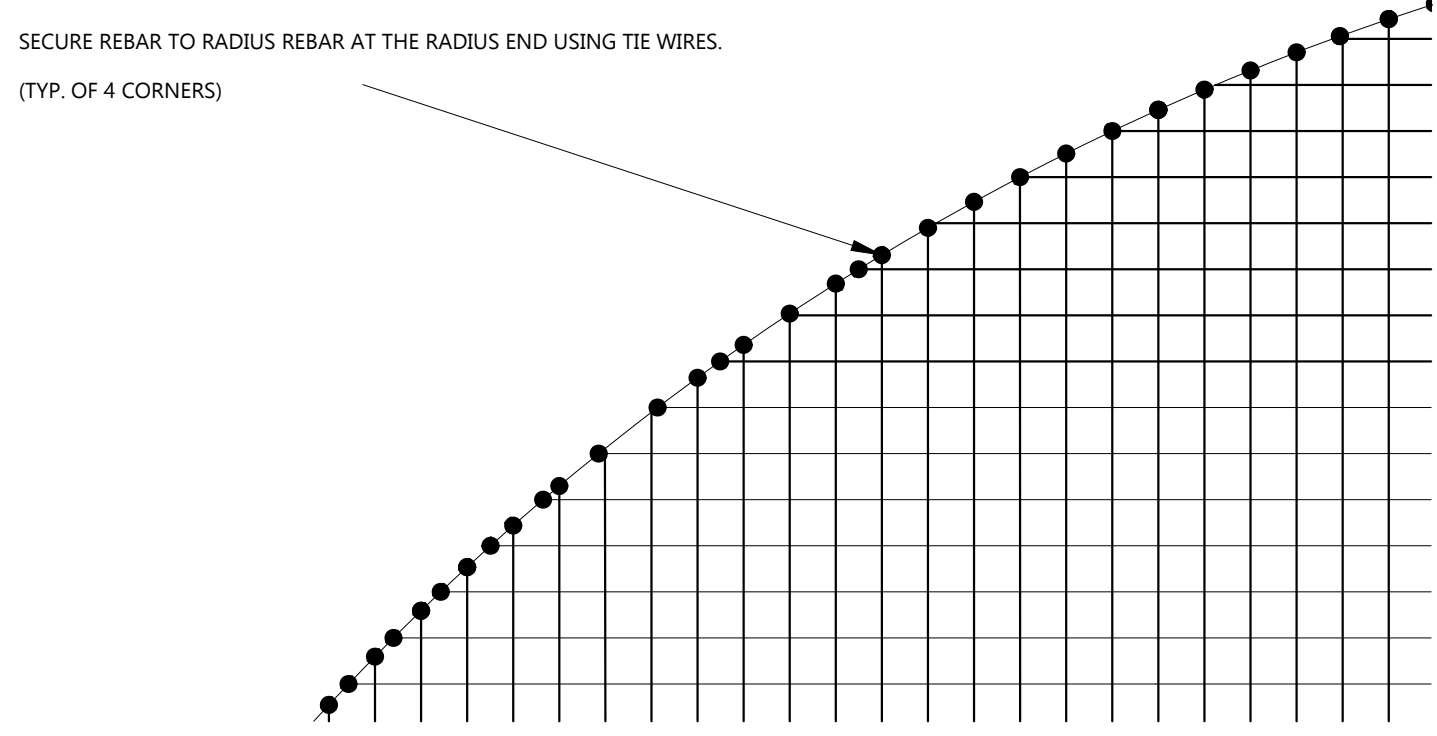

DETAIL D: RADIUS REBAR DETAIL
NTS

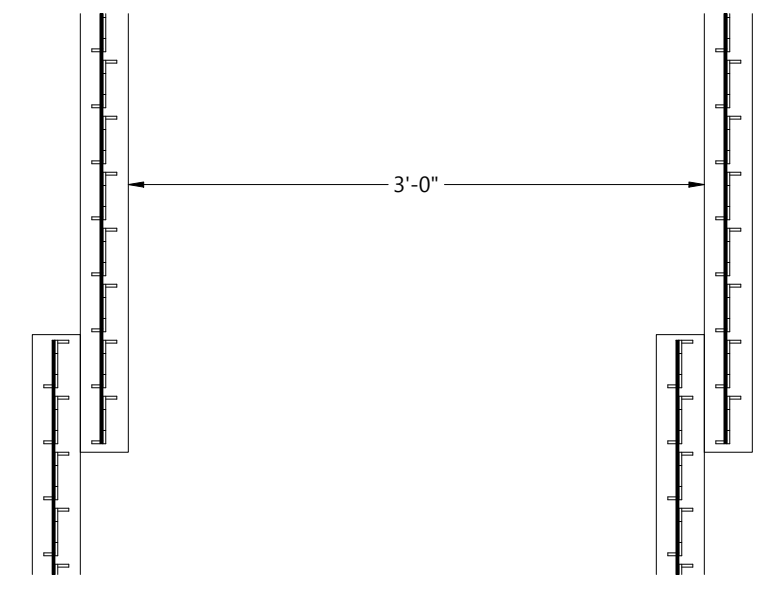

DETAIL E: PIPE CHAIR DETAIL
SCALE 1"=1'-0"

PIPE CHAIR SPECIFICATIONS:

- "M" STYLE WITH CONTINUOUS METAL BASE
- PIPE: 1" 13.5 SDR HDPE PIPE. 1 3/8" OD
- PIPE CENTERS: 3 1/2"
- 20 SPACES PER SUPPORT
- TOTAL HEIGHT: 3.4"
- PIPE LIFT: 2.00"
- TOP REBAR LIFT: 1.50"
- BASE PLATES: 3" X 24 GAUGE SPACED 36" ON CENTRE
- 36" SPACING
- TWO (2) PIPE OVERLAP

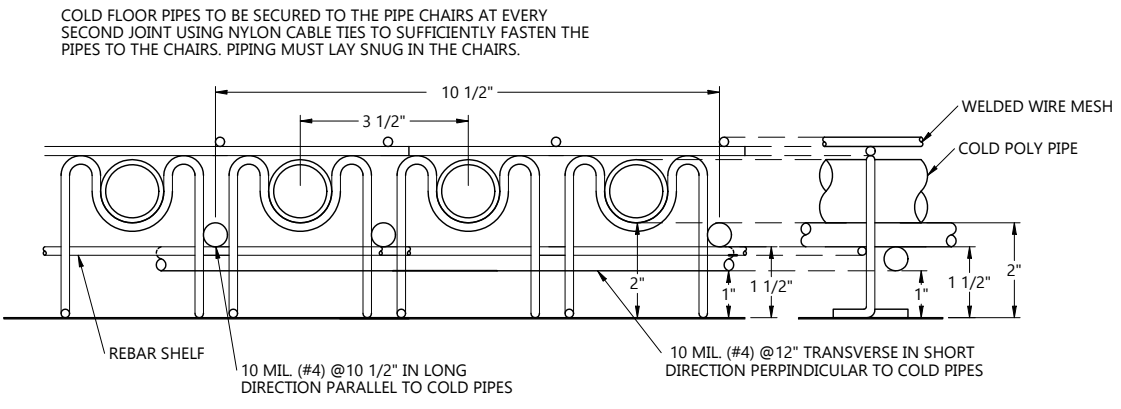

DETAIL F: PIPE CHAIR DETAIL
SCALE 3"=1'-0"

SUPPLY AND INSTALL BOTTOM LAYER REINFORCING REBAR:

- REBAR TYPE: 10 MIL (#4) REBAR.
- INSTALL LOWER REBAR FIRST PARALLEL TO PIPE CHAIRS (PERPENDICULAR WITH FLOOR PIPING) WITH 12" ON CENTER SPACING.
- INSTALL UPPER REBAR SECOND PARALLEL TO COLD FLOOR PIPES WITH 10 1/2" ON CENTER SPACING. UPPER REBAR TO SIT IN PIPE CHAIRS.
- SECURE REBAR TO PIPE CHAIRS USING TIE WIRES AT EVERY THREE INTERSECTIONS, STAGGERING TIES AT EVERY CHAIR.

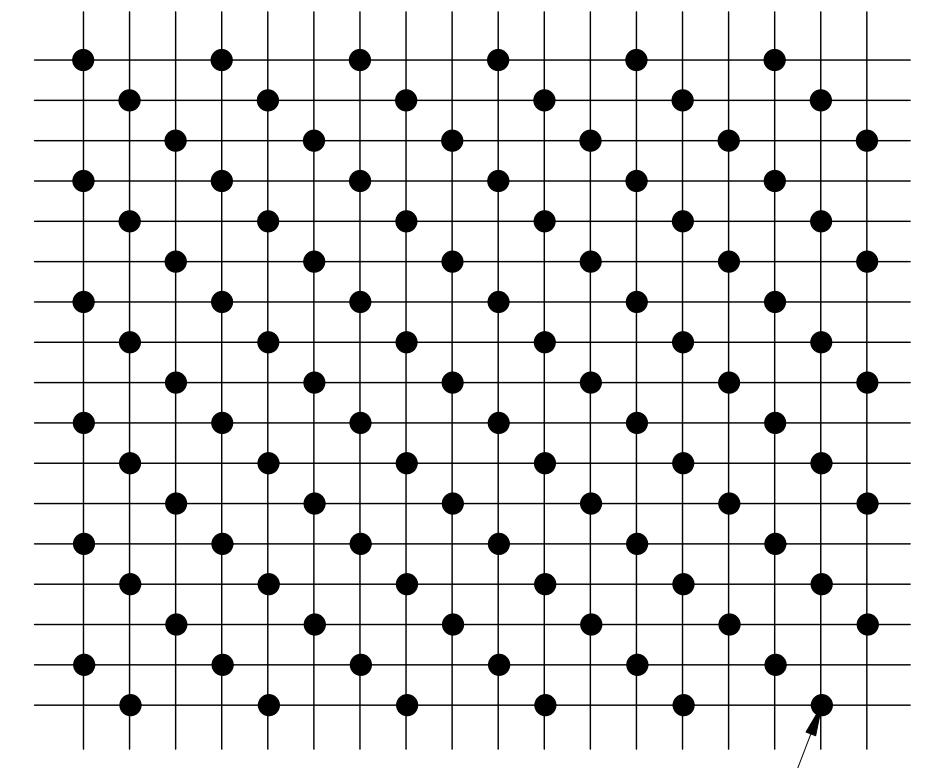

DETAIL G: REBAR DETAIL
NTS

REINFORCEMENT

NOTES

---	NEW
---	EXISTING

REFERENCE DEFINITION	
SHEET COLUMN	SHEET ROW
(#, X#)	

COPYRIGHT AND DISCLAIMER
THIS WORK IS THE SOLE PROPERTY OF I.B. STOREY INC AND IS INTENDED SOLELY FOR THE INFORMATION OF THE CLIENT. ALL RIGHTS RESERVED. THE WORK MAY NOT BE REPRODUCED OR DISTRIBUTED, WHOLE OR IN PART, WITHOUT THE PRIOR WRITTEN PERMISSION OF I.B. STOREY INC. THIS DOCUMENT MAY NOT BE USED FOR ANY OTHER PROJECTS OR WITHOUT INVOLVEMENT OF I.B. STOREY INC. ANY USE WHICH A THIRD PARTY MAKES OF THE WORK, OR ANY RELIANCE ON OR DECISIONS TO BE MADE BASED ON IT, ARE THE RESPONSIBILITY OF SUCH THIRD PARTIES.

- NOT FOR CONSTRUCTION -
CONFIDENTIAL & PROPRIETARY

VER #	REVISIONS	DATE	BY
4.0	ISSUED FOR DETAILED DESIGN	05-SEP-24	V.K.
3.0	ISSUED FOR SCHEMATIC DESIGN	28-JUN-24	V.K.
2.0	ISSUED FOR CONCEPTUAL DESIGN	29-MAY-24	E.K.
1.0	ISSUED FOR WORKSHOP	06-MAY-24	V.K.



CHARLOTTETOWN PE
VAUGHAN ON
REDINGTON SHORES FL
PLANO TX

WWW.IBSTOREY.COM

STAMP

DRAWING NUMBER 24009 MR503	
DRAWING NAME RINK FLOOR DETAILS	
CLIENT SPRINGFIELD PARK DISTRICT	
PROJECT SPRINGFIELD - PLANT REPLACEMENT	
DRAWN BY V.KOFANOV	CHECKED BY J. RITCHIE
DATE 05-SEP-24	REVISION 4.0
SHEET SIZE C	SHEET NO. 2 OF 10

24009 MR503

1

2

3

4

5

NOTES

---	NEW
---	EXISTING

REFERENCE DEFINITION	
SHEET COLUMN	SHEET ROW
(#, X#)	

COPYRIGHT AND DISCLAIMER
 THIS WORK IS THE SOLE PROPERTY OF I.B. STOREY INC AND IS INTENDED SOLELY FOR THE INFORMATION OF THE CLIENT. ALL RIGHTS RESERVED. THE WORK MAY NOT BE REPRODUCED OR DISTRIBUTED, WHOLE OR IN PART, WITHOUT THE PRIOR WRITTEN PERMISSION OF I.B. STOREY INC.
 THIS DOCUMENT MAY NOT BE USED FOR ANY OTHER PROJECTS OR WITHOUT INVOLVEMENT OF I.B. STOREY INC. ANY USE WHICH A THIRD PARTY MAKES OF THE WORK, OR ANY RELIANCE ON OR DECISIONS TO BE MADE BASED ON IT, ARE THE RESPONSIBILITY OF SUCH THIRD PARTIES.

- NOT FOR CONSTRUCTION -
 CONFIDENTIAL & PROPRIETARY

VER #	REVISIONS	DATE	BY
4.0	ISSUED FOR DETAILED DESIGN	05-SEP-24	V.K.
3.0	ISSUED FOR SCHEMATIC DESIGN	28-JUN-24	V.K.
2.0	ISSUED FOR CONCEPTUAL DESIGN	29-MAY-24	E.K.
1.0	ISSUED FOR WORKSHOP	06-MAY-24	V.K.



CHARLOTTETOWN PE
 VAUGHAN ON
 REDINGTON SHORES FL
 PLANO TX

WWW.IBSTOREY.COM

DRAWING NUMBER		24009 MR503	
DRAWING NAME		RINK FLOOR DETAILS	
CLIENT		SPRINGFIELD PARK DISTRICT	
PROJECT		SPRINGFIELD - PLANT REPLACEMENT	
DRAWN BY	V.KOFANOV	CHECKED BY	J. RITCHIE
DATE	05-SEP-24	REVISION	4.0
SHEET SIZE	C	SHEET NO.	3 OF 10

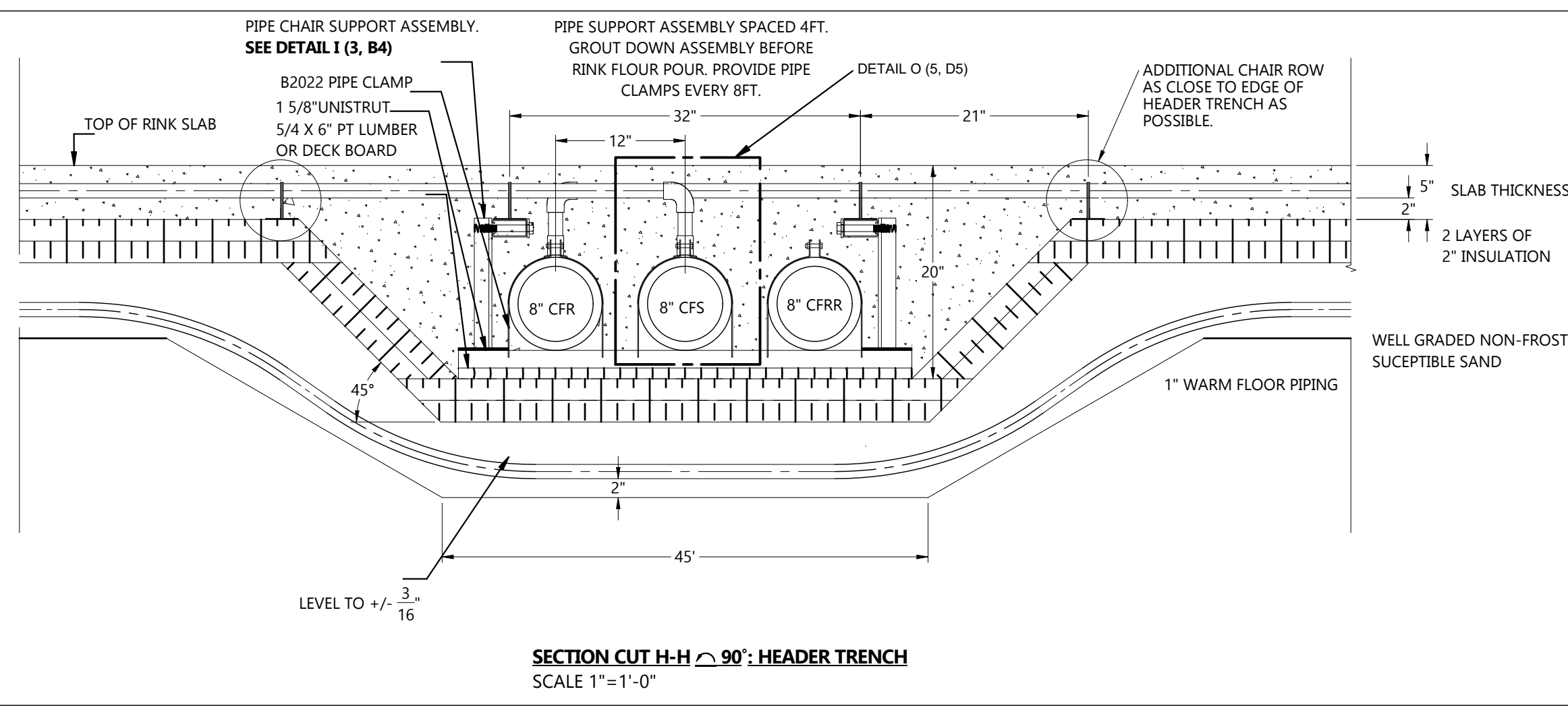

TESTING

PRESSURE TESTING

DESIGN ENGINEER SHALL WITNESS PRESSURE TESTING. PROVIDE MINIMUM ONE MONTH NOTICE OF TEST DATES.
 FAILED TESTS INCLUDE
 • LOSS OF PRESSURE
 • PIPE DAMAGE
 • ANY SEAL FAILURE (INCLUDES JOINT WELDS)
 RETESTING IS REQUIRED FOLLOWING CORRECTION OF DEFECTS AFTER ANY FAILED TESTS.

WARM FLOOR CIRCUIT PRESSURE TESTING

PRESSURE: 100 PSIG, AIR
 DURATION: 24-HOURS, CONTINUOUS
 TEST COMPLETE CIRCUIT INCLUDING HEADERS AND FLOOR TUBES.
 COMPLETE TESTING 48 HOURS PRIOR TO SAND FILLING.
 AFTER PRESSURE TESTING APPROVAL BY DESIGN ENGINEER, REDUCE TO 50 PSIG AND HOLD FOR DURATION OF SAND FILL AND COMPACTING.

COLD FLOOR CIRCUIT PRESSURE TESTING

PRESSURE: 100 PSIG, AIR
 DURATION: 24-HOURS, CONTINUOUS
 TEST COMPLETE CIRCUIT INCLUDING HEADERS AND FLOOR TUBES.
 COMPLETE TESTING 48 HOURS PRIOR TO CONCRETE POUR.
 AFTER PRESSURE TESTING APPROVAL BY DESIGN ENGINEER, REDUCE TO 50 PSIG AND HOLD FOR DURATION OF CONCRETE POUR.

FLOOR TOLERANCE TESTING

COMPLETE LASER LEVELING AND TOLERANCE REPORTS FOLLOWING COMPLETION OF EACH LAYER:

- SAND LAYER
- INSULATION
- FINISHED CONCRETE

PROVIDE TEST RESULTS TO OWNER AND DESIGN ENGINEER WITHIN 24 HOURS OF ALL TESTING. ALL FINISHED CONCRETE TESTING MUST BE COMPLETED WITHIN 72 HOURS OF POUR COMPLETION. TEST RESULTS MUST BE ACKNOWLEDGED BY DESIGN ENGINEER PRIOR TO ADVANCING TO NEXT STAGE.
 RESULTS OUTSIDE REQUIRED TOLERANCES REQUIRE CORRECTION AND RETESTING. NO COMPENSATION WILL BE APPROVED FOR DEFICIENCY CORRECTION.

SIDE VIEW

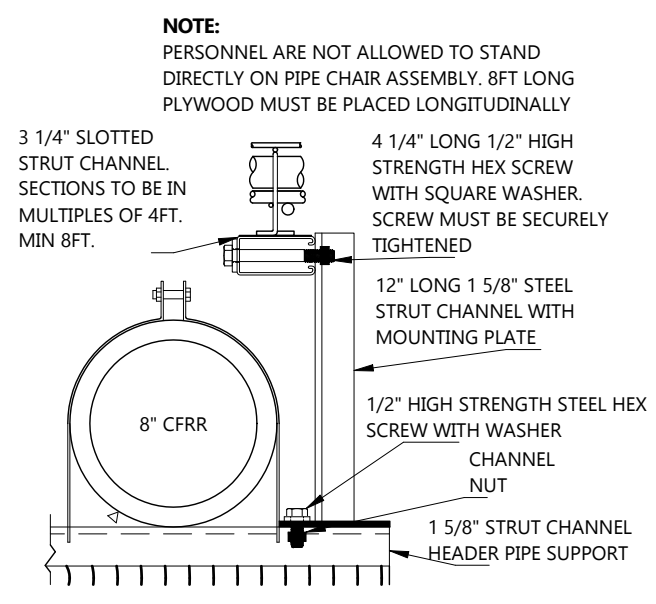

FRONT VIEW

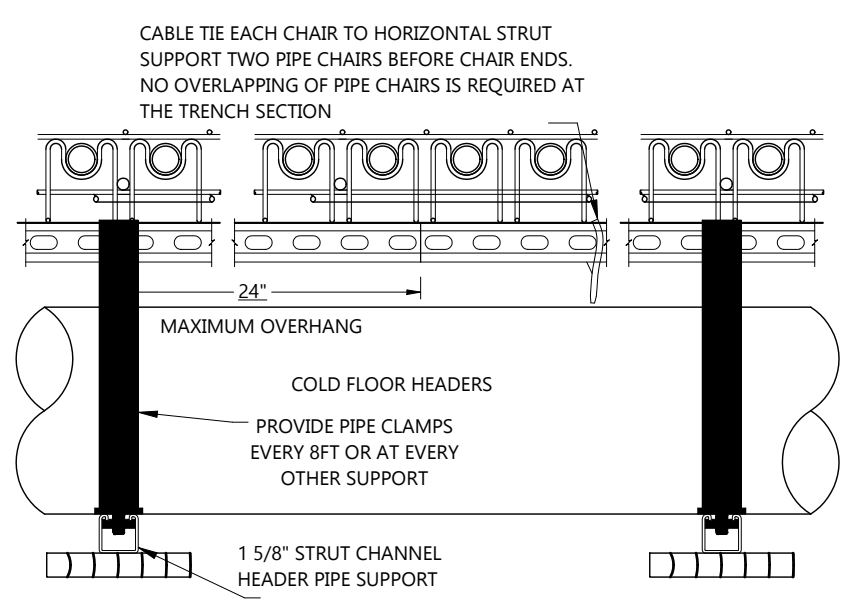

ALTERNATE SUPPORT ASSEMBLY - OR APPROVED EQUIVALENT

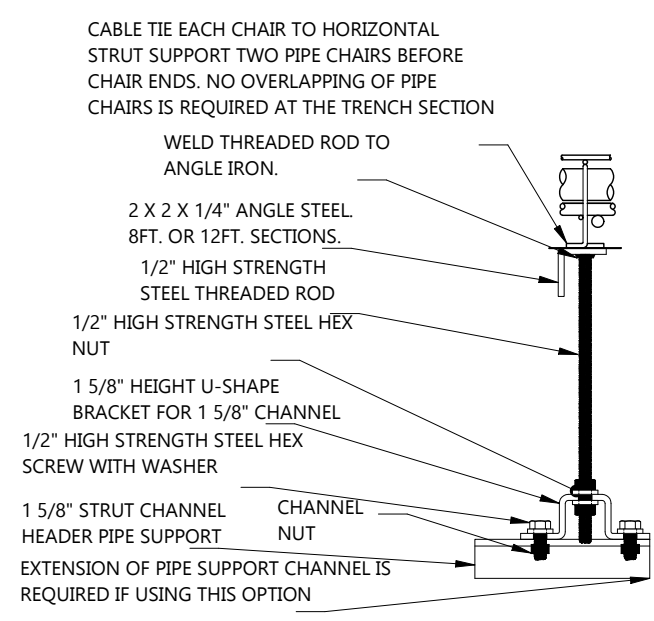

DETAIL I (3, A1): TRENCH PIPE CHAIR SUPPORT FRAME
 SCALE 1-1/2"=1'-0"

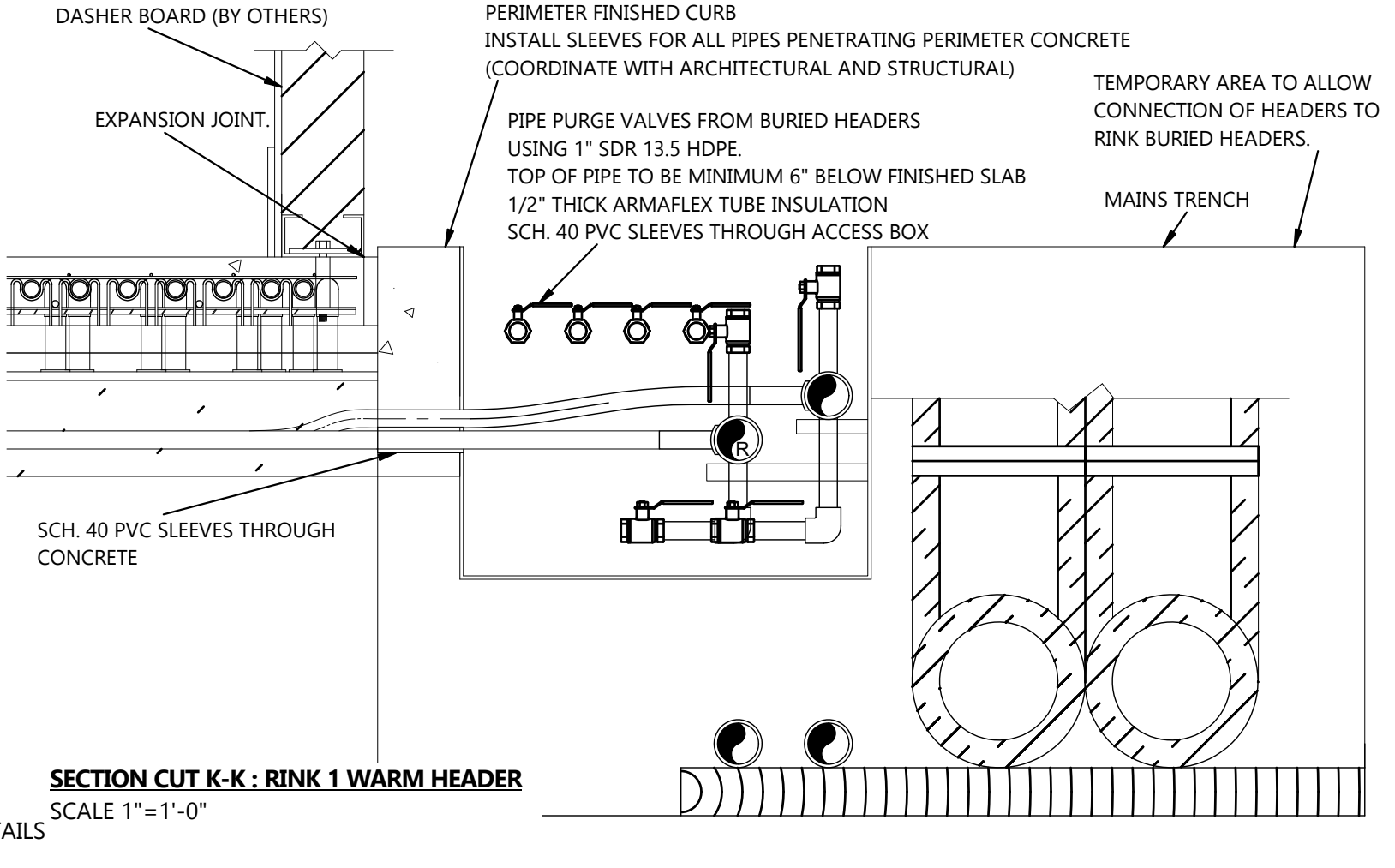
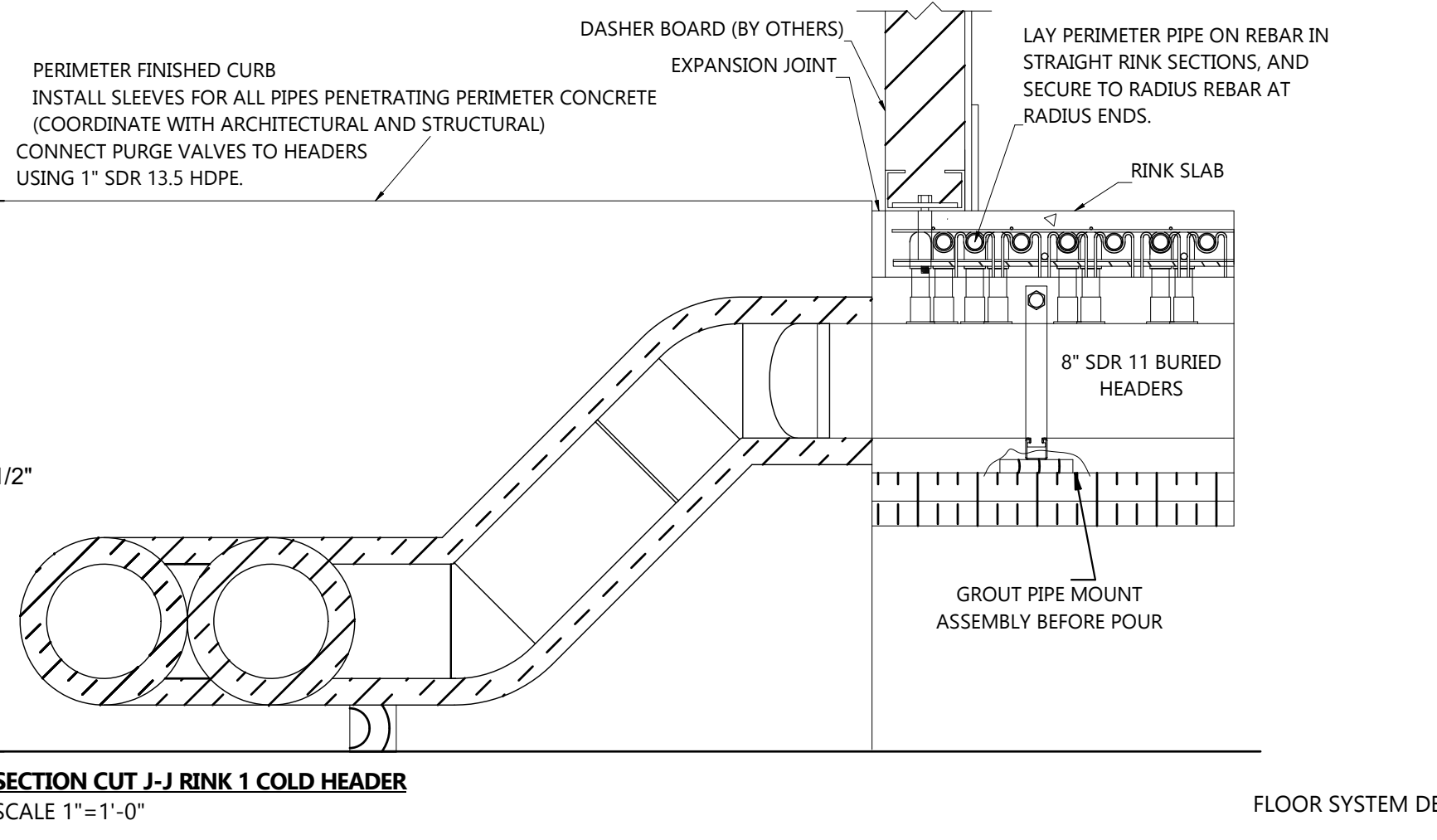

FLOOR SYSTEM DETAILS

1

2

3

4

5

NOTES

---	NEW
---	EXISTING

REFERENCE DEFINITION	
SHEET COLUMN	SHEET ROW
SHEET NUMBER	(#, X#)

COPYRIGHT AND DISCLAIMER
 THIS WORK IS THE SOLE PROPERTY OF I.B. STOREY INC AND IS INTENDED SOLELY FOR THE INFORMATION OF THE CLIENT. ALL RIGHTS RESERVED. THE WORK MAY NOT BE REPRODUCED OR DISTRIBUTED, WHOLE OR IN PART, WITHOUT THE PRIOR WRITTEN PERMISSION OF I.B. STOREY INC.
 THIS DOCUMENT MAY NOT BE USED FOR ANY OTHER PROJECTS OR WITHOUT INVOLVEMENT OF I.B. STOREY INC. ANY USE WHICH A THIRD PARTY MAKES OF THE WORK, OR ANY RELIANCE ON OR DECISIONS TO BE MADE BASED ON IT, ARE THE RESPONSIBILITY OF SUCH THIRD PARTIES.

- NOT FOR CONSTRUCTION -
CONFIDENTIAL & PROPRIETARY

VER #	REVISIONS	DATE	BY
4.0	ISSUED FOR DETAILED DESIGN	05-SEP-24	V.K.
3.0	ISSUED FOR SCHEMATIC DESIGN	28-JUN-24	V.K.
2.0	ISSUED FOR CONCEPTUAL DESIGN	29-MAY-24	E.K.
1.0	ISSUED FOR WORKSHOP	06-MAY-24	V.K.



CHARLOTTETOWN PE
 VAUGHAN ON
 REDINGTON SHORES FL
 PLANO TX

WWW.IBSTOREY.COM

STAMP

DRAWING NUMBER 24009 MR503	
DRAWING NAME RINK FLOOR DETAILS	
CLIENT SPRINGFIELD PARK DISTRICT	
PROJECT SPRINGFIELD - PLANT REPLACEMENT	
DRAWN BY V.KOFANOV	CHECKED BY J. RITCHIE
DATE 05-SEP-24	REVISION 4.0
SHEET SIZE C	SHEET NO. 4 OF 10

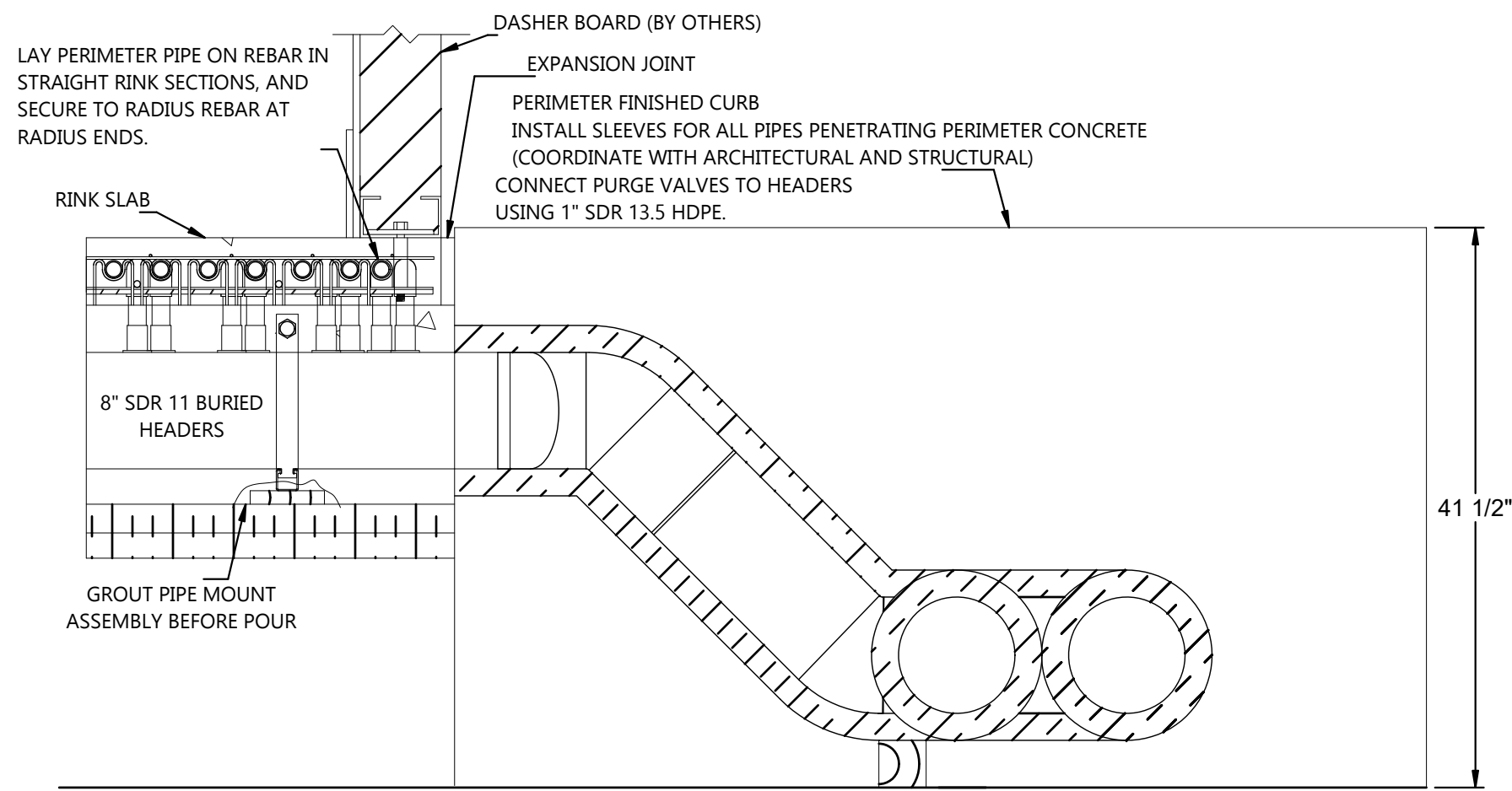

SECTION CUT L-L RINK 2 COLD HEADER
 SCALE 1"=1'-0"

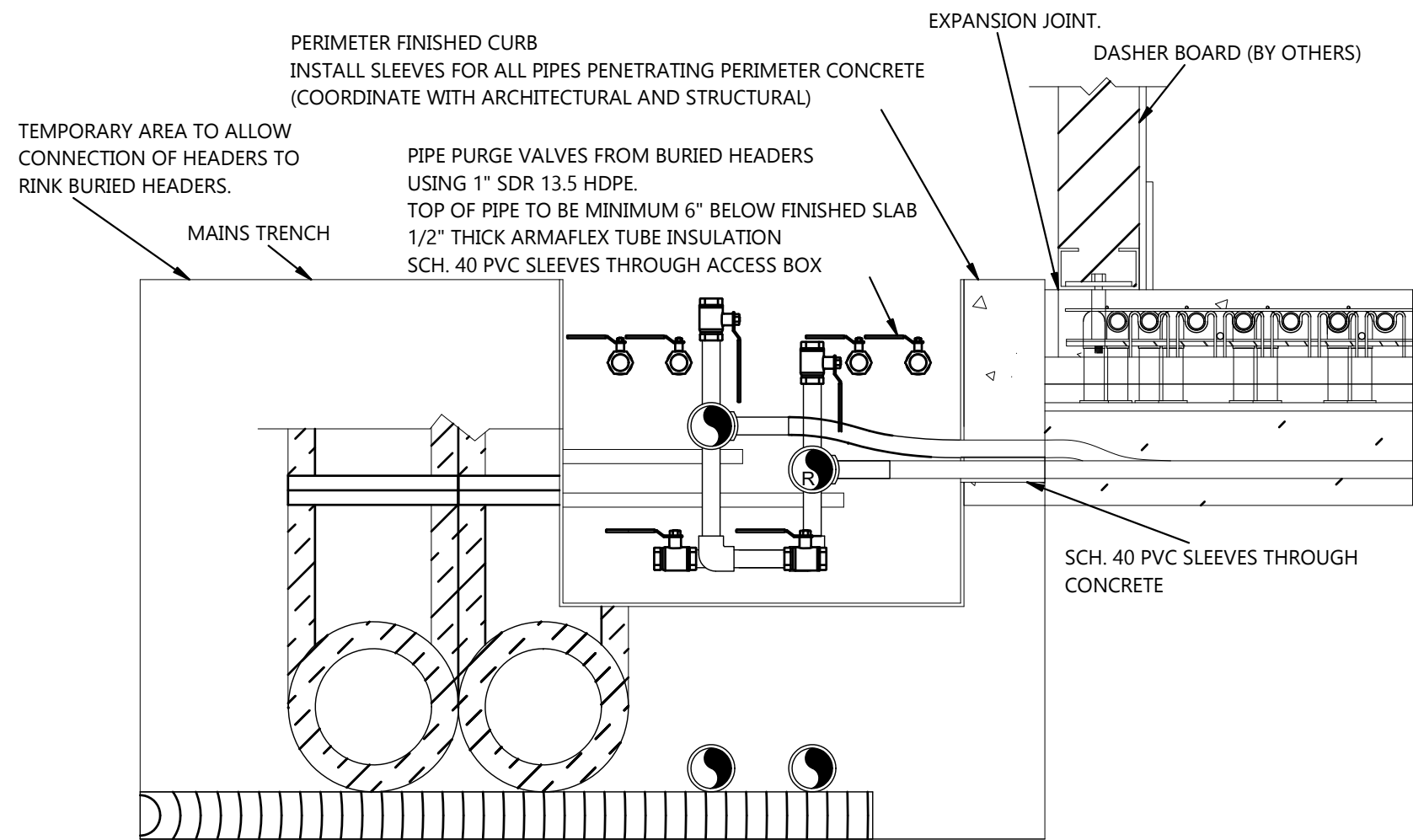

SECTION CUT M-M : RINK 2 WARM HEADER
 SCALE 1"=1'-0"

TESTING

PRESSURE TESTING

DESIGN ENGINEER SHALL WITNESS PRESSURE TESTING. PROVIDE MINIMUM ONE MONTH NOTICE OF TEST DATES.

FAILED TESTS INCLUDE

- LOSS OF PRESSURE
- PIPE DAMAGE
- ANY SEAL FAILURE (INCLUDES JOINT WELDS)

RETESTING IS REQUIRED FOLLOWING CORRECTION OF DEFECTS AFTER ANY FAILED TESTS.

WARM FLOOR CIRCUIT PRESSURE TESTING

PRESSURE: 100 PSIG, AIR

DURATION: 24-HOURS, CONTINUOUS

TEST COMPLETE CIRCUIT INCLUDING HEADERS AND FLOOR TUBES.

COMPLETE TESTING 48 HOURS PRIOR TO SAND FILLING.

AFTER PRESSURE TESTING APPROVAL BY DESIGN ENGINEER, REDUCE TO 50 PSIG AND HOLD FOR DURATION OF SAND FILL AND COMPACTING.

COLD FLOOR CIRCUIT PRESSURE TESTING

PRESSURE: 100 PSIG, AIR

DURATION: 24-HOURS, CONTINUOUS

TEST COMPLETE CIRCUIT INCLUDING HEADERS AND FLOOR TUBES.

COMPLETE TESTING 48 HOURS PRIOR TO CONCRETE POUR.

AFTER PRESSURE TESTING APPROVAL BY DESIGN ENGINEER, REDUCE TO 50 PSIG AND HOLD FOR DURATION OF CONCRETE POUR.

FLOOR TOLERANCE TESTING

COMPLETE LASER LEVELING AND TOLERANCE REPORTS FOLLOWING COMPLETION OF EACH LAYER:

- SAND LAYER
- INSULATION
- FINISHED CONCRETE

PROVIDE TEST RESULTS TO OWNER AND DESIGN ENGINEER WITHIN 24 HOURS OF ALL TESTING.

ALL FINISHED CONCRETE TESTING MUST BE COMPLETED WITHIN 72 HOURS OF POUR COMPLETION.

TEST RESULTS MUST BE ACKNOWLEDGED BY DESIGN ENGINEER PRIOR TO ADVANCING TO NEXT STAGE.

RESULTS OUTSIDE REQUIRED TOLERANCES REQUIRE CORRECTION AND RETESTING. NO COMPENSATION WILL BE APPROVED FOR DEFICIENCY CORRECTION.

41 1/2"

NOTES

---	NEW
---	EXISTING

REFERENCE DEFINITION	
SHEET COLUMN	SHEET ROW
SHEET NUMBER	(#, X#)

COPYRIGHT AND DISCLAIMER
 THIS WORK IS THE SOLE PROPERTY OF I.B. STOREY INC AND IS INTENDED SOLELY FOR THE INFORMATION OF THE CLIENT. ALL RIGHTS RESERVED. THE WORK MAY NOT BE REPRODUCED OR DISTRIBUTED, WHOLE OR IN PART, WITHOUT THE PRIOR WRITTEN PERMISSION OF I.B. STOREY INC.
 THIS DOCUMENT MAY NOT BE USED FOR ANY OTHER PROJECTS OR WITHOUT INVOLVEMENT OF I.B. STOREY INC. ANY USE WHICH A THIRD PARTY MAKES OF THE WORK, OR ANY RELIANCE ON OR DECISIONS TO BE MADE BASED ON IT, ARE THE RESPONSIBILITY OF SUCH THIRD PARTIES.

- NOT FOR CONSTRUCTION -
 CONFIDENTIAL & PROPRIETARY

VER #	REVISIONS	DATE	BY
4.0	ISSUED FOR DETAILED DESIGN	05-SEP-24	V.K.
3.0	ISSUED FOR SCHEMATIC DESIGN	28-JUN-24	V.K.
2.0	ISSUED FOR CONCEPTUAL DESIGN	29-MAY-24	E.K.
1.0	ISSUED FOR WORKSHOP	06-MAY-24	V.K.



CHARLOTTETOWN PE
 VAUGHAN ON
 REDINGTON SHORES FL
 PLANO TX

WWW.IBSTOREY.COM

STAMP
DRAWING NUMBER 24009 MR503
DRAWING NAME RINK FLOOR DETAILS
CLIENT SPRINGFIELD PARK DISTRICT
PROJECT SPRINGFIELD - PLANT REPLACEMENT
DRAWN BY V.KOFANOV
CHECKED BY J. RITCHIE
DATE 05-SEP-24
REVISION 4.0
SHEET SIZE C
SHEET NO. 5 OF 10

COLD FLOOR NOTES:

GENERAL

PIPE MATERIAL: HDPE
 ALL TUBING CONNECTIONS AND INTERFACES TO BE FUSION WELDED.

HEADERS

MATERIAL: HDPE
 SIZE: 8" SDR 11
 SADDLES FUSION WELDED TO HEADERS FOR CONNECTION TO FLOOR PIPES
 SADDLE SPACING: 7" O/C
 SADDLE QTY. PER HEADER: 148
 HEADER PIPING OUTSIDE RINK FLOOR BOUNDARY WRAPPED IN INSULATION.

VALVES

DRAINS:

- QTY: TWO X 1" DRAIN VALVE
- FUSION WELD TO HEADER USING 1" SDR 13.5 HDPE TUBING
- INSTALL IN ACCESS BOX TO SUPPLY AND RETURN HEADERS.

PURGE VALVES

- QTY: TWO X 1" PURGE VALVE
- FUSION WELD TO HEADER USING 1" SDR 13.5 HDPE TUBING
- POSITION UPRIGHT.
- INSTALL ON SUPPLY AND RETURN HEADERS IN ACCESS BOX

FLOOR TUBING

MATERIAL: HDPE
 SIZE: 1" SDR 13.5
 SPACING: 3-1/2" O/C
 FUSION WELD EACH CIRCUIT TO SUPPLY/RETURN HEADERS.
 SECURE TUBING TO PIPE CHAIRS USING CABLE TIES.

PERIMETER CHILL RING

FASTEN PERIMETER CHILL RING DIRECTLY TO PERIMETER REBAR ANCHORS USING CABLE TIES. CABLE TIES TO BE PROVIDED AS REQUIRED TO ENSURE NO MOVEMENT OF THE CHILL RINGS, MAXIMUM 24" APART.

RETURN BENDS

ONE-PIECE, PRE-MANUFACTURED 180° U-BEND (TYP.)
 MATERIAL: HDPE
 SIZE: 1" IPS SDR 13.5
 SPACING: 3-1/2" O/C OFFSET
 SOCKET FUSION WELDED TO FLOOR PIPES
 CABLE TIE RETURN BENDS DIRECTLY TO PERIMETER REBAR ANCHORS TO TENSION THE SYSTEM AND MINIMIZE SAGGING.

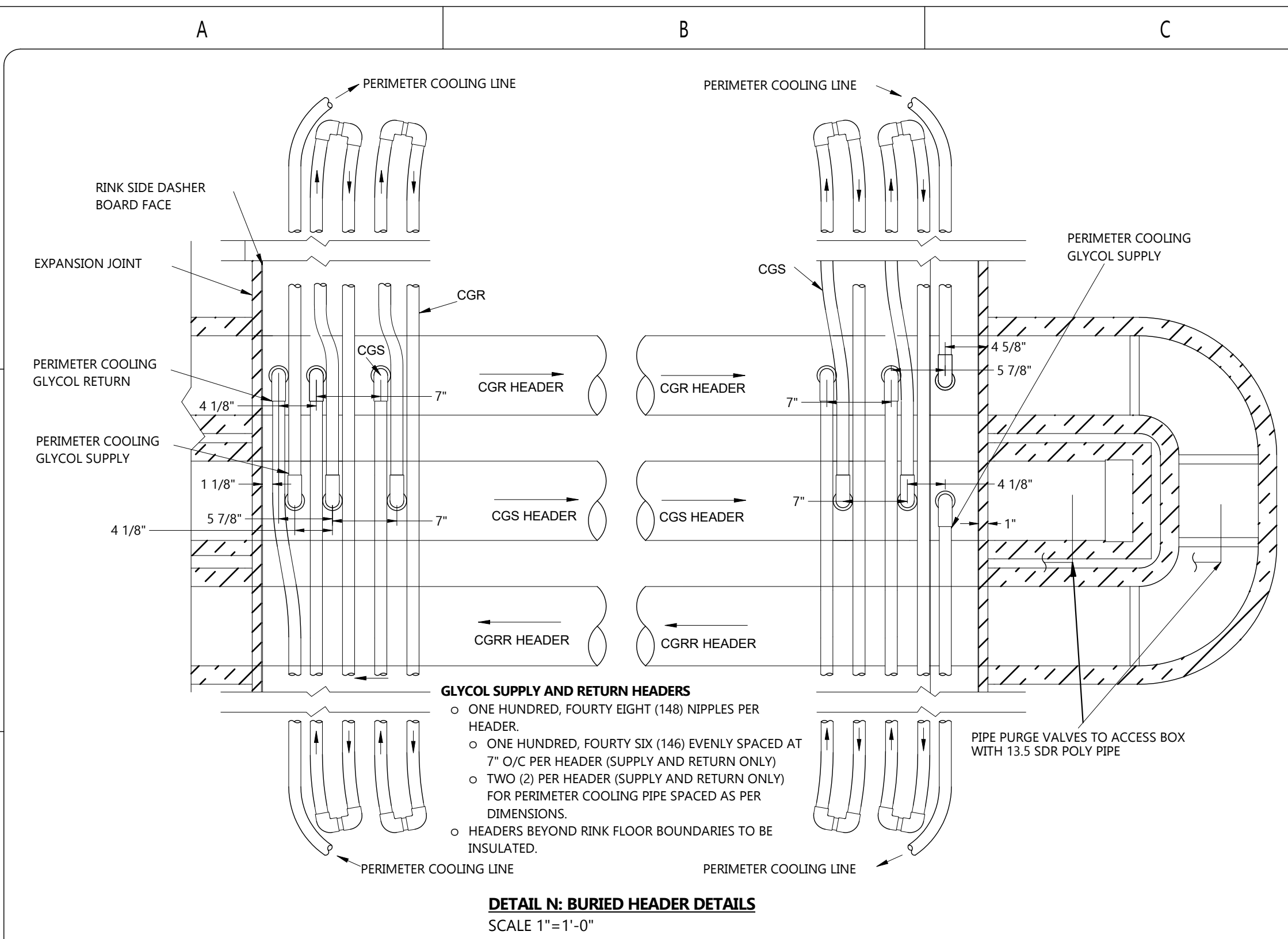

DETAIL N: BURIED HEADER DETAILS
 SCALE 1"=1'-0"

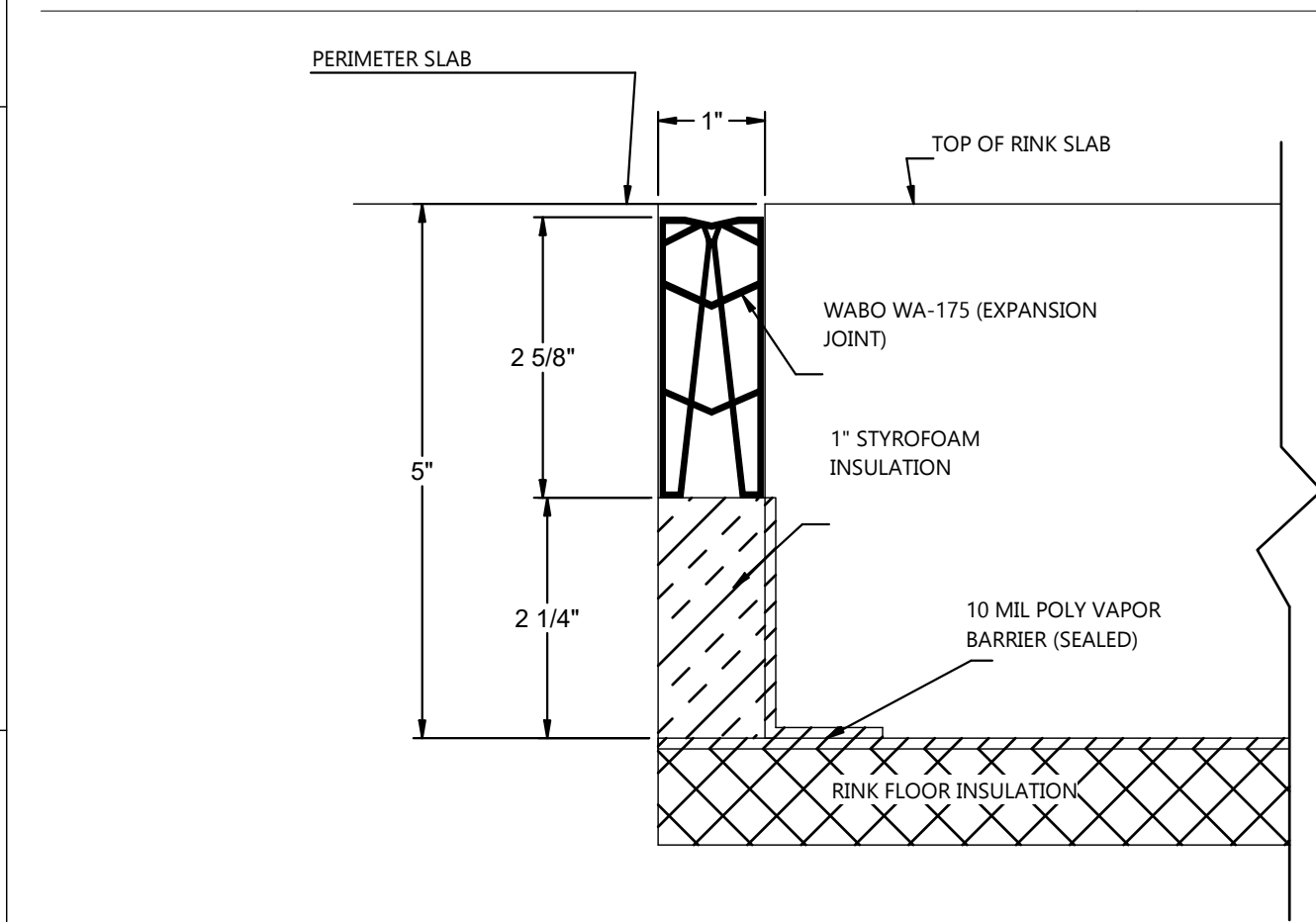

SECTION CUT B-B (1, E2): EXPANSION JOINT DETAIL
 NTS

PREPARATION

- INSTALL 1" x 5" STYROFOAM INSULATION IN ONE SCORED PIECE OR TWO PIECES, SCORE OR TOP PIECE IS 2-6/8". INSTALL VAPOR BARRIER TO TOP OF 5" HIGH INSULATION ON THE RINK SIDE OF THE EXPANSION JOINT. AFTER CONCRETE SLAB IS POURED AND CURED, REMOVE TOP PIECE OF INSULATION AND TRIM VAPOR BARRIER BACK 2-6/8".
- INSTALL WABO WA-175 AS PER LATEST MANUFACTURER INSTALLATION MANUALS AT TIME OF INSTALL.
- TOP OF SEAL 1/8" BELOW FINISHED SLAB.
- THE SEAL SHOULD NEVER PROTRUDE ABOVE THE JOINT EDGE AS PER LATEST MANUFACTURER INSTALLATION MANUAL.

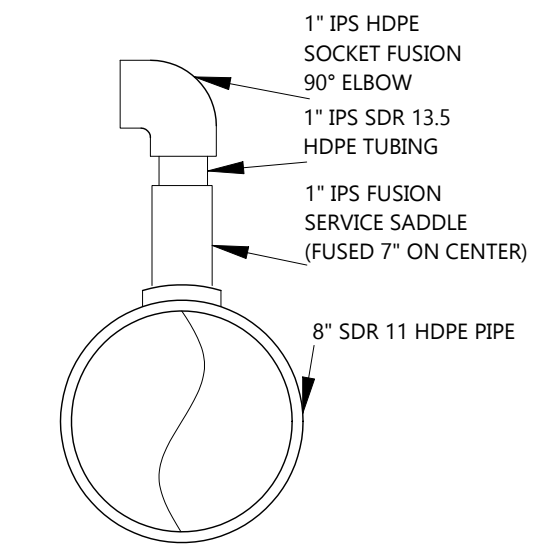

DETAIL O (3, B1): PIPE SADDLE DETAIL
 NTS

FLOOR SYSTEM DETAILS

NOTES

---	NEW
---	EXISTING

REFERENCE DEFINITION	
SHEET COLUMN	SHEET ROW
SHEET NUMBER	(#, X#)

COPYRIGHT AND DISCLAIMER
 THIS WORK IS THE SOLE PROPERTY OF I.B. STOREY INC AND IS INTENDED SOLELY FOR THE INFORMATION OF THE CLIENT. ALL RIGHTS RESERVED. THE WORK MAY NOT BE REPRODUCED OR DISTRIBUTED, WHOLE OR IN PART, WITHOUT THE PRIOR WRITTEN PERMISSION OF I.B. STOREY INC.
 THIS DOCUMENT MAY NOT BE USED FOR ANY OTHER PROJECTS OR WITHOUT INVOLVEMENT OF I.B. STOREY INC. ANY USE WHICH A THIRD PARTY MAKES OF THE WORK, OR ANY RELIANCE ON OR DECISIONS TO BE MADE BASED ON IT, ARE THE RESPONSIBILITY OF SUCH THIRD PARTIES.

- NOT FOR CONSTRUCTION -
 CONFIDENTIAL & PROPRIETARY

4.0	ISSUED FOR DETAILED DESIGN	05-SEP-24	V.K.
3.0	ISSUED FOR SCHEMATIC DESIGN	28-JUN-24	V.K.
2.0	ISSUED FOR CONCEPTUAL DESIGN	29-MAY-24	E.K.
1.0	ISSUED FOR WORKSHOP	06-MAY-24	V.K.
VER #	REVISIONS	DATE	BY

I.B. STOREY
 Rink Engineering Experts

CHARLOTTETOWN PE
 VAUGHAN ON
 REDINGTON SHORES FL
 PLANO TX

WWW.IBSTOREY.COM

STAMP

DRAWING NUMBER	
24009 MR503	
DRAWING NAME	
RINK FLOOR DETAILS	
CLIENT	
SPRINGFIELD PARK DISTRICT	
PROJECT	
SPRINGFIELD - PLANT REPLACEMENT	
DRAWN BY	CHECKED BY
V.KOFANOV	J. RITCHIE
DATE	REVISION
05-SEP-24	4.0
SHEET SIZE	SHEET NO.
C	6 OF 10

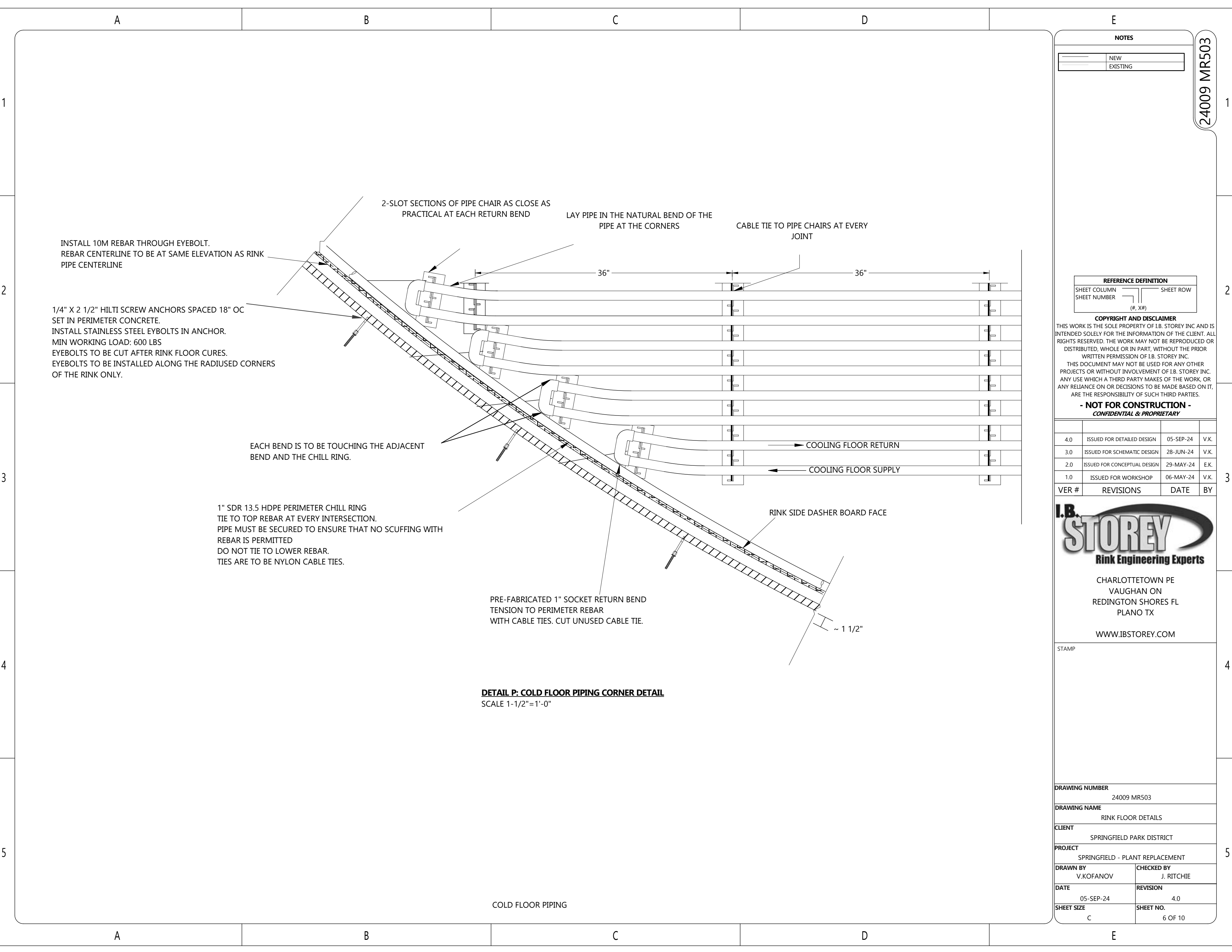

INSTALL 10M REBAR THROUGH EYEBOLT.
 REBAR CENTERLINE TO BE AT SAME ELEVATION AS RINK
 PIPE CENTERLINE

1/4" X 2 1/2" HILTI SCREW ANCHORS SPACED 18" OC
 SET IN PERIMETER CONCRETE.
 INSTALL STAINLESS STEEL EYBOLTS IN ANCHOR.
 MIN WORKING LOAD: 600 LBS
 EYBOLTS TO BE CUT AFTER RINK FLOOR CURES.
 EYBOLTS TO BE INSTALLED ALONG THE RADIUSED CORNERS
 OF THE RINK ONLY.

EACH BEND IS TO BE TOUCHING THE ADJACENT
 BEND AND THE CHILL RING.

1" SDR 13.5 HDPE PERIMETER CHILL RING
 TIE TO TOP REBAR AT EVERY INTERSECTION.
 PIPE MUST BE SECURED TO ENSURE THAT NO SCUFFING WITH
 REBAR IS PERMITTED
 DO NOT TIE TO LOWER REBAR.
 TIES ARE TO BE NYLON CABLE TIES.

PRE-FABRICATED 1" SOCKET RETURN BEND
 TENSION TO PERIMETER REBAR
 WITH CABLE TIES. CUT UNUSED CABLE TIE.

DETAIL P: COLD FLOOR PIPING CORNER DETAIL
 SCALE 1-1/2"=1'-0"

COLD FLOOR PIPING

NOTE:
REFER TO MR401, MR503 (SHEET 3, 4) FOR THE EXACT ACCESS BOX LOCATION AND DETAILED INFORMATION.

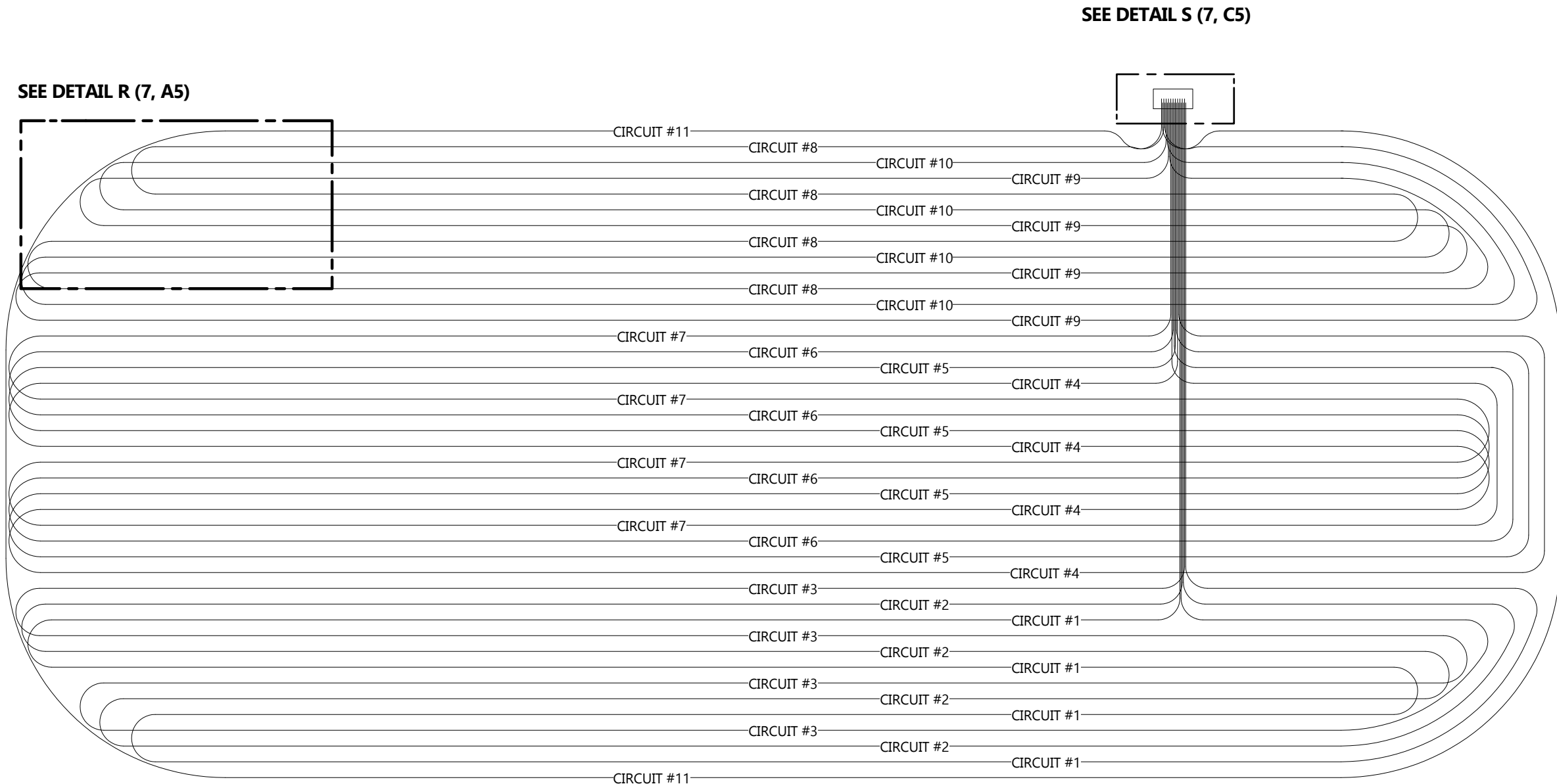

DETAIL Q: WARM FLOOR CIRCUITS
SCALE 1/16"=1'-0"

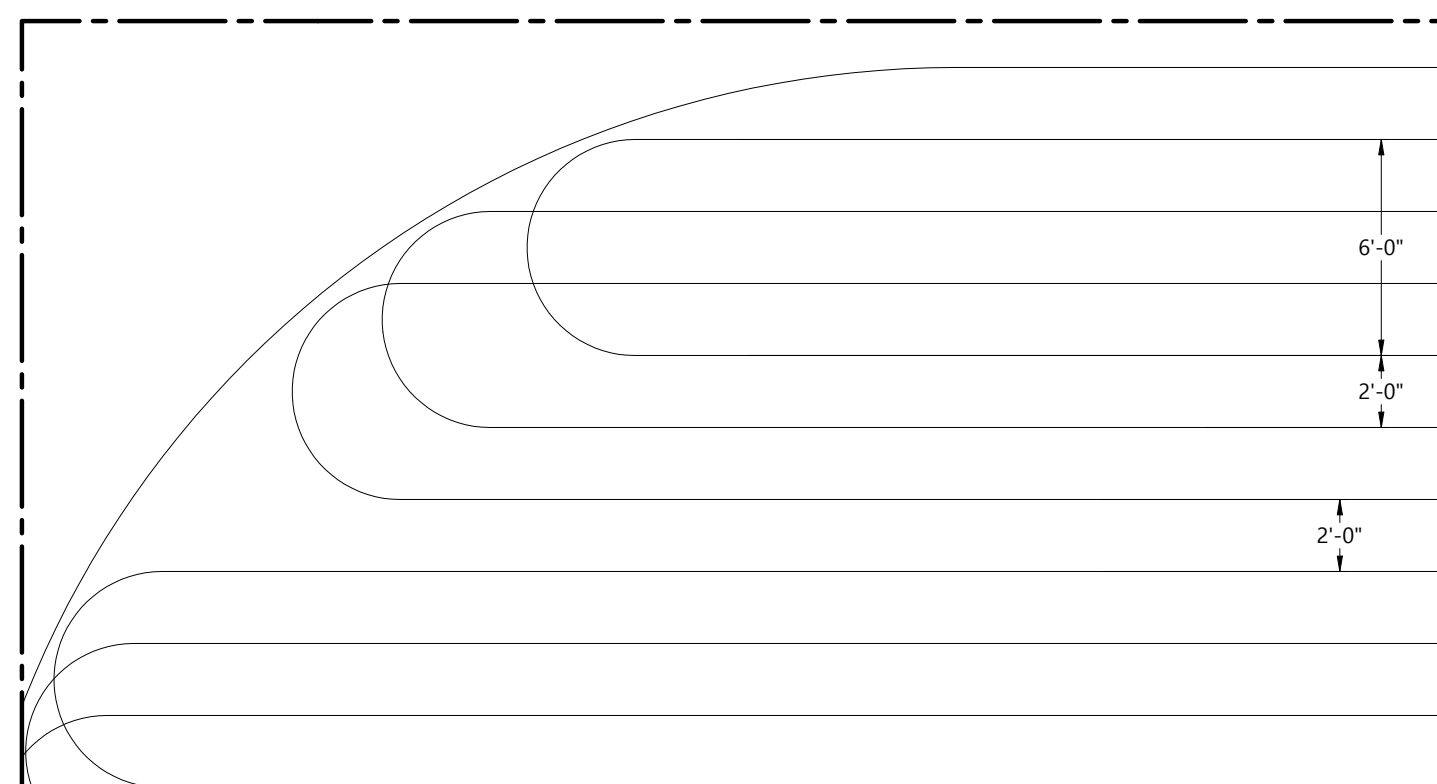

DETAIL R (7, A1): WARM FLOOR PIPING DETAIL
SCALE 3/16"=1'-0"

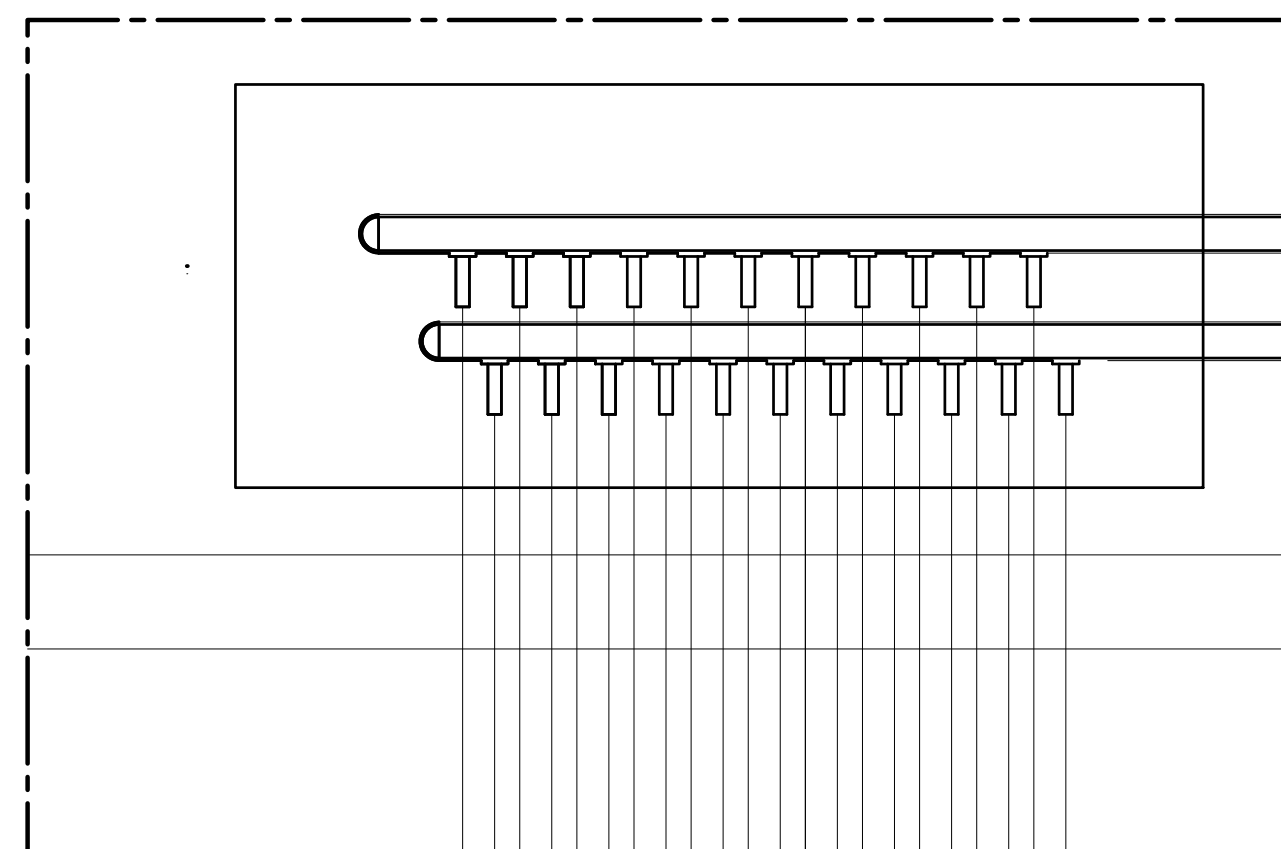

DETAIL S (7, C1): STUBBY HEADER DETAIL
NTS

WARM FLOOR PIPING

NOTES

---	NEW
---	EXISTING

REFERENCE DEFINITION

SHEET COLUMN	SHEET ROW
(#, X#)	

COPYRIGHT AND DISCLAIMER
THIS WORK IS THE SOLE PROPERTY OF I.B. STOREY INC AND IS INTENDED SOLELY FOR THE INFORMATION OF THE CLIENT. ALL RIGHTS RESERVED. THE WORK MAY NOT BE REPRODUCED OR DISTRIBUTED, WHOLE OR IN PART, WITHOUT THE PRIOR WRITTEN PERMISSION OF I.B. STOREY INC.
THIS DOCUMENT MAY NOT BE USED FOR ANY OTHER PROJECTS OR WITHOUT INVOLVEMENT OF I.B. STOREY INC. ANY USE WHICH A THIRD PARTY MAKES OF THE WORK, OR ANY RELIANCE ON OR DECISIONS TO BE MADE BASED ON IT, ARE THE RESPONSIBILITY OF SUCH THIRD PARTIES.

- NOT FOR CONSTRUCTION -
CONFIDENTIAL & PROPRIETARY

VER #	REVISIONS	DATE	BY
4.0	ISSUED FOR DETAILED DESIGN	05-SEP-24	V.K.
3.0	ISSUED FOR SCHEMATIC DESIGN	28-JUN-24	V.K.
2.0	ISSUED FOR CONCEPTUAL DESIGN	29-MAY-24	E.K.
1.0	ISSUED FOR WORKSHOP	06-MAY-24	V.K.



CHARLOTTETOWN PE
VAUGHAN ON
REDINGTON SHORES FL
PLANO TX

WWW.IBSTOREY.COM

STAMP

DRAWING NUMBER 24009 MR503	
DRAWING NAME RINK FLOOR DETAILS	
CLIENT SPRINGFIELD PARK DISTRICT	
PROJECT SPRINGFIELD - PLANT REPLACEMENT	
DRAWN BY V.KOFANOV	CHECKED BY J. RITCHIE
DATE 05-SEP-24	REVISION 4.0
SHEET SIZE C	SHEET NO. 7 OF 10

WARM FLOOR NOTES:

- .1 WARM FLOOR MAINS
 - .1 SUPPLY AND INSTALL TWO (2) PIPES FOR THE WARM FLOOR MAINS, SUPPLY AND RETURN, FROM THE BURIED HEADER PIPING TO THE REFRIGERATION PLANT ROOM AND CONNECTING INSIDE THE PLANT ROOM TO THE EXISTING PIPES.
 - .2 PIPE SPECIFICATION: 3" HDPE SDR 11, FUSION WELDED.

- .2 WARM FLOOR STUBBY HEADER:
 - .1 SUPPLY AND INSTALL TWO (2) 3" HDPE SUPPLY AND RETURN HEADER PIPES, CIRCULATING WARMED FLUID TO PREVENT FROST HEAVING IN THE RINK FLOOR. HEADER PIPES SHALL BE RUN FROM THE REFRIGERATION ROOM.
 - .2 INCLUDES THIRTEEN (13) SETS OF FUSION SERVICE SADDLE CONNECTIONS FUSION WELDED TO EACH OF THE STUBBY HEADERS.
 - .3 CONTRACTOR TO SUPPLY AND INSTALL TWO (2) DRAINS, COMPLETE WITH VALVES, AND TWO (2) PURGE VALVES (VENT) WITH CONNECTIONS, ONE (1) PER HEADER.
 - .1 PROVIDE 1" PURGE VALVES AT BOTH ENDS OF SUPPLY AND RETURN HEADERS.
 - .2 CONNECT PURGE VALVES TO HEADERS USING 1" SDR 13.5 HDPE PIPE. SADDLES ARE ALSO AN APPROVED EQUIVALENT.
 - .3 PURGE VALVE PIPING MUST NOT SLOPE DOWNWARDS TO ENSURE AIR IS NOT TRAPPED IN THE LINE, AND THE VALVES MUST BE INSTALLED IN THE ACCESS BOX.
 - .4 ALL VALVES TO BE OF STEEL BODIES AND BE FITTED WITH HAND WHEELS (GRIPS).

- .1 WARM FLOOR PIPING
 - .1 SUPPLY AND INSTALL WARM FLOOR PIPING, BOTH SUPPLY AND RETURN PIPING RUNNING PARALLEL TO EACH OTHER AND CONNECTED TO EACH HEADER NIPPLE. PIPING MUST EXTEND THE ENTIRE LENGTH AND WIDTH OF THE NEW ICE SLAB STRUCTURE. FUSION SERVICE SADDLES MAY ALSO BE USED.
 - .2 PIPE SIZE: 1" SDR 13.5
 - .3 MATERIAL: HDPE
 - .4 SPACED 24" ON CENTER.
 - .5 PROVIDE RIGID INSULATION TO WARM FLOOR PIPING ONLY LOCATED IN THE ACCESS BOX.
 - .6 HEADER CONNECTIONS: ALL JOINTS TO BE FULLY FUSION WELDED TO STUBBY HEADER IN THE ACCESS BOX.

WARM FLOOR ADDITIONAL NOTES:

GENERAL
 MATERIAL: HDPE
 ALL PIPE CONNECTIONS AND INTERFACES TO BE FUSION WELDED.

STUBBY HEADERS
 MATERIAL: HDPE
 SIZE: 3" SDR 11
 SADDLES FUSION WELDED TO SUPPLY AND RETURN HEADERS FOR CONNECTION TO FLOOR PIPES
 SADDLE QTY PER HEADER: 11

WARM FLOOR PIPING
 MATERIAL: HDPE
 SIZE: 1" SDR 13.5
 SPACING:
 TYP. 24" O/C
 18" FROM SLAB PERIMETER
 FUSION WELD EACH CIRCUIT TO SUPPLY/RETURN STUBBY HEADERS.

WARM FLOOR NOTES

NOTES

NEW
EXISTING

24009 MR503

REFERENCE DEFINITION	
SHEET COLUMN	SHEET ROW
SHEET NUMBER	(#, X#)

COPYRIGHT AND DISCLAIMER
 THIS WORK IS THE SOLE PROPERTY OF I.B. STOREY INC AND IS INTENDED SOLELY FOR THE INFORMATION OF THE CLIENT. ALL RIGHTS RESERVED. THE WORK MAY NOT BE REPRODUCED OR DISTRIBUTED, WHOLE OR IN PART, WITHOUT THE PRIOR WRITTEN PERMISSION OF I.B. STOREY INC.
 THIS DOCUMENT MAY NOT BE USED FOR ANY OTHER PROJECTS OR WITHOUT INVOLVEMENT OF I.B. STOREY INC. ANY USE WHICH A THIRD PARTY MAKES OF THE WORK, OR ANY RELIANCE ON OR DECISIONS TO BE MADE BASED ON IT, ARE THE RESPONSIBILITY OF SUCH THIRD PARTIES.

- NOT FOR CONSTRUCTION -
CONFIDENTIAL & PROPRIETARY

VER #	REVISIONS	DATE	BY
4.0	ISSUED FOR DETAILED DESIGN	05-SEP-24	V.K.
3.0	ISSUED FOR SCHEMATIC DESIGN	28-JUN-24	V.K.
2.0	ISSUED FOR CONCEPTUAL DESIGN	29-MAY-24	E.K.
1.0	ISSUED FOR WORKSHOP	06-MAY-24	V.K.



CHARLOTTETOWN PE
 VAUGHAN ON
 REDINGTON SHORES FL
 PLANO TX
 WWW.IBSTOREY.COM

STAMP

DRAWING NUMBER 24009 MR503	
DRAWING NAME RINK FLOOR DETAILS	
CLIENT SPRINGFIELD PARK DISTRICT	
PROJECT SPRINGFIELD - PLANT REPLACEMENT	
DRAWN BY V.KOFANOV	CHECKED BY J. RITCHIE
DATE 05-SEP-24	REVISION 4.0
SHEET SIZE C	SHEET NO. 8 OF 10

- ICE RINK FLOOR SYSTEM SUMMARY**
 TOTAL SYSTEM DEPTH FROM PERIMETER FINISHED FLOOR: 16"
- TOP OF RINK SLAB FLUSH WITH PERIMETER SLAB
 - 5" CONCRETE
 - TOP LAYER REINFORCEMENT WIREMESH
 - COLD FLOOR 1" POLY PIPING
 - M-STYLE PIPE CHAIRS
 - BOTTOM LAYER REINFORCING REBAR GRID
 - VAPOR BARRIER
 - 4" INSULATION (2X2" LAYERS)
 - VAPOR BARRIER
 - 7" SAND BASE
 - WARM FLOOR 1" POLY PIPING
 - EXISTING GRANULAR SUB-BASE BELOW

TOP LAYER REINFORCING (ABOVE RINK PIPING)
 6x6x6/6 WELDED WIRE MESH PLACED ON TOP OF RINK
 PIPE SUPPORTS ACROSS WHOLE AREA OF RINK SLAB
 TRIMMED CORNERS W/ 2 LAYERS OVERLAP MAX
 FLAT SHEETS ONLY

1" SDR 13.5 HDPE COOLING
 RINK PIPES SPACED 3 1/2" O/C

PIPE SUPPORTS
 OVERLAP CHAIRS TWO ROWS
 AT EACH END. INSTALL REBAR
 ON PIPE CHAIR
 ISOLATION CHANNEL

5" CONCRETE SLAB FINISHED LEVEL
 1-3/4" MAXIMUM CONCRETE
 COVERAGE OVER RINK PIPES

BOTTOM LAYER REINFORCING REBAR. LOWER REBAR INSTALLED FIRST
 PARALLEL TO RINK PIPES SUPPORTS (12" SPACING).
 UPPER REBAR INSTALLED SECOND PARALLEL TO RINK PIPE (10-1/2" SPACING).
 REBAR TO BE TIED AT EVERY INTERSECTION ALONG THE DIAGONAL,
 STARTING AT EVERY THIRD REBAR INTERSECTION ALONG THE
 LENGTH OF THE RINK

10 MIL (#4) THICK POLYETHYLENE
 VAPOUR BARRIER SLIP SHEETS

PIPE LAID 5" BELOW BOTTOM OF VAPOUR BARRIER

CLEAN SAND, LEVELLED TO +3/16"
 SAND TO BE FREE FROM CLAY, SHALE, AND ORGANIC MATTER

TWO LAYERS OF 2" THICK
 DOW RIGID SM EXTRUDED POLYSTYRENE
 INSULATION LEVELLED TO +3/16" TOLERANCES

1" SDR 13.5 POLYETHYLENE
 UNDERFLOOR HEATING
 PIPES SPACED 24" O/C

GRANULAR SUB-BASE

SAMPLE RINK FLOOR SECTION (EXAGGERATED FOR CLARITY)
 NTS

FLOOR ISOMETRIC VIEW

NOTES

---	NEW
---	EXISTING

REFERENCE DEFINITION

SHEET COLUMN	SHEET ROW
(#, X#)	

COPYRIGHT AND DISCLAIMER
 THIS WORK IS THE SOLE PROPERTY OF I.B. STOREY INC AND IS
 INTENDED SOLELY FOR THE INFORMATION OF THE CLIENT. ALL
 RIGHTS RESERVED. THE WORK MAY NOT BE REPRODUCED OR
 DISTRIBUTED, WHOLE OR IN PART, WITHOUT THE PRIOR
 WRITTEN PERMISSION OF I.B. STOREY INC.
 THIS DOCUMENT MAY NOT BE USED FOR ANY OTHER
 PROJECTS OR WITHOUT INVOLVEMENT OF I.B. STOREY INC.
 ANY USE WHICH A THIRD PARTY MAKES OF THE WORK, OR
 ANY RELIANCE ON OR DECISIONS TO BE MADE BASED ON IT,
 ARE THE RESPONSIBILITY OF SUCH THIRD PARTIES.

- NOT FOR CONSTRUCTION -
CONFIDENTIAL & PROPRIETARY

VER #	REVISIONS	DATE	BY
4.0	ISSUED FOR DETAILED DESIGN	05-SEP-24	V.K.
3.0	ISSUED FOR SCHEMATIC DESIGN	28-JUN-24	V.K.
2.0	ISSUED FOR CONCEPTUAL DESIGN	29-MAY-24	E.K.
1.0	ISSUED FOR WORKSHOP	06-MAY-24	V.K.

I.B. STOREY
Rink Engineering Experts

CHARLOTTETOWN PE
 VAUGHAN ON
 REDINGTON SHORES FL
 PLANO TX

WWW.IBSTOREY.COM

STAMP

DRAWING NUMBER	
24009 MR503	
DRAWING NAME	
RINK FLOOR DETAILS	
CLIENT	
SPRINGFIELD PARK DISTRICT	
PROJECT	
SPRINGFIELD - PLANT REPLACEMENT	
DRAWN BY	CHECKED BY
V.KOFANOV	J. RITCHIE
DATE	REVISION
05-SEP-24	4.0
SHEET SIZE	SHEET NO.
C	9 OF 10

24009 MR503

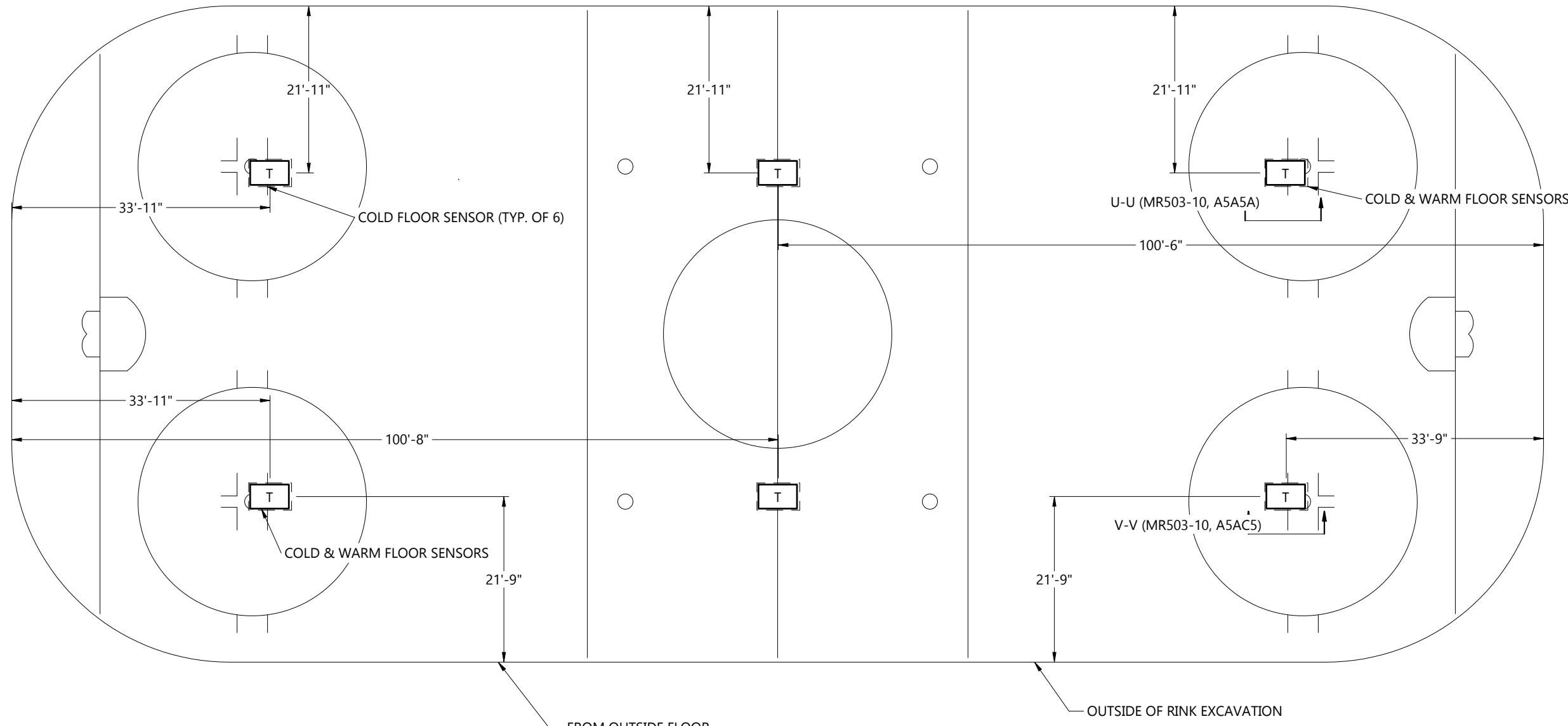

DETAIL T: RINK FLOOR SENSOR LOCATIONS PLAN
SCALE 1/16"=1'-0"

- NOTES:**
- MEASUREMENTS TO CENTRE OF SENSOR BOX.
 - MOVE AS NEEDED TO AVOID PIPES IN FLOOR, PIPES TO BEND AROUND SENSOR BOX.

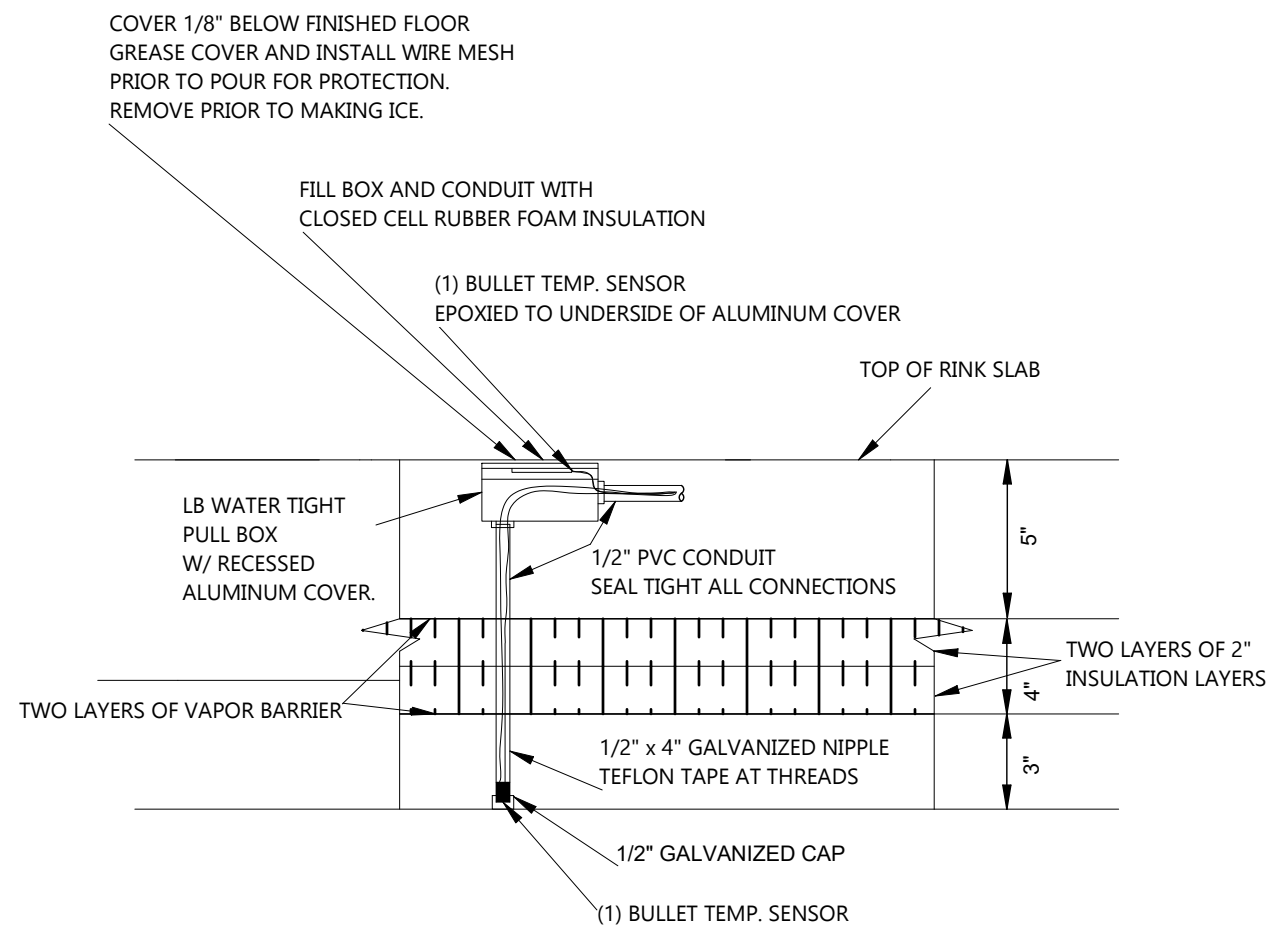

SECTION CUT U-U (10, D2): COLD & WARM INFLOOR SENSOR DETAIL
NTS

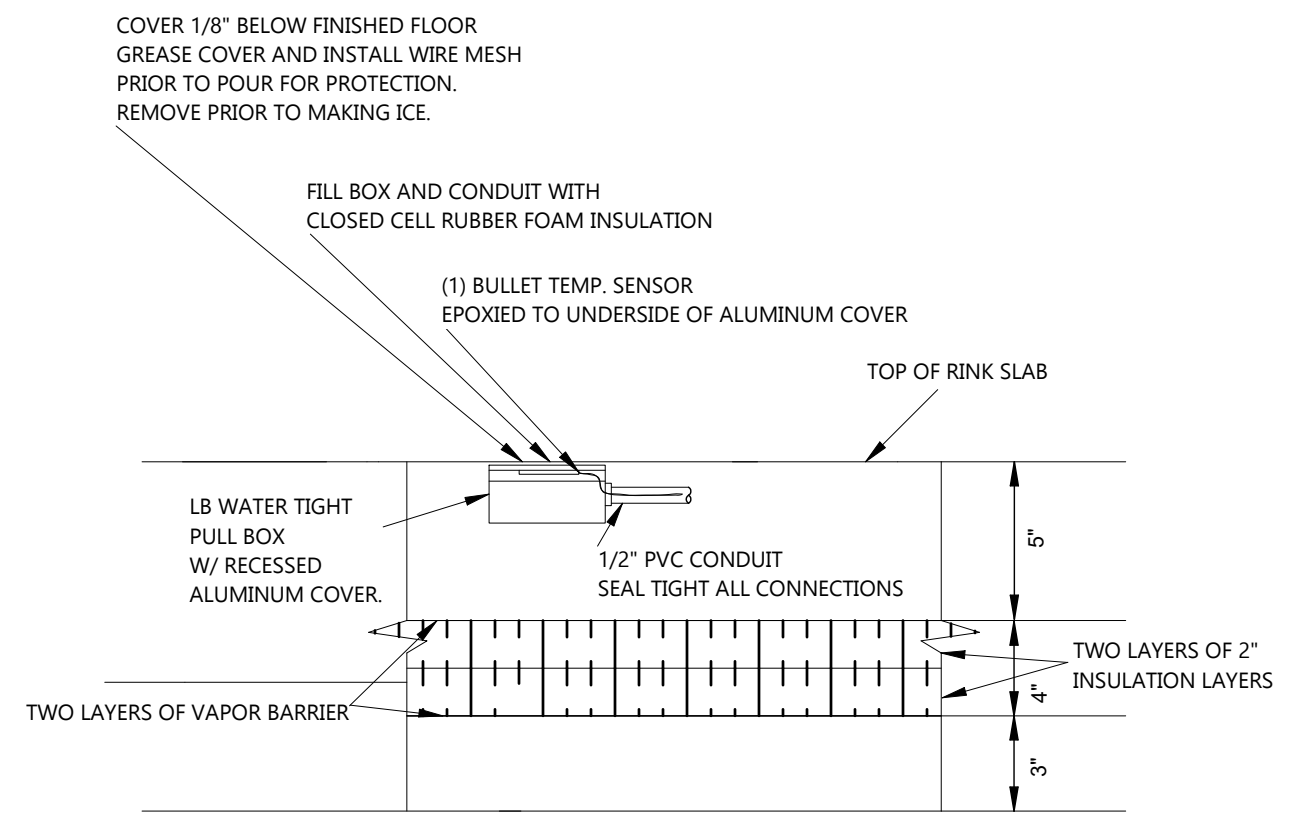

SECTION CUT V-V (10, D2): COLD INFLOOR SENSOR DETAIL
NTS

RINK SENSOR LOCATIONS & INSTALLATION

NOTES

---	NEW
---	EXISTING

REFERENCE DEFINITION

SHEET COLUMN	SHEET ROW
(#, X#)	

COPYRIGHT AND DISCLAIMER
THIS WORK IS THE SOLE PROPERTY OF I.B. STOREY INC AND IS INTENDED SOLELY FOR THE INFORMATION OF THE CLIENT. ALL RIGHTS RESERVED. THE WORK MAY NOT BE REPRODUCED OR DISTRIBUTED, WHOLE OR IN PART, WITHOUT THE PRIOR WRITTEN PERMISSION OF I.B. STOREY INC.
THIS DOCUMENT MAY NOT BE USED FOR ANY OTHER PROJECTS OR WITHOUT INVOLVEMENT OF I.B. STOREY INC. ANY USE WHICH A THIRD PARTY MAKES OF THE WORK, OR ANY RELIANCE ON OR DECISIONS TO BE MADE BASED ON IT, ARE THE RESPONSIBILITY OF SUCH THIRD PARTIES.

- NOT FOR CONSTRUCTION -
CONFIDENTIAL & PROPRIETARY

VER #	REVISIONS	DATE	BY
4.0	ISSUED FOR DETAILED DESIGN	05-SEP-24	V.K.
3.0	ISSUED FOR SCHEMATIC DESIGN	28-JUN-24	V.K.
2.0	ISSUED FOR CONCEPTUAL DESIGN	29-MAY-24	E.K.
1.0	ISSUED FOR WORKSHOP	06-MAY-24	V.K.



CHARLOTTETOWN PE
VAUGHAN ON
REDINGTON SHORES FL
PLANO TX

WWW.IBSTOREY.COM

STAMP

DRAWING NUMBER 24009 MR503	
DRAWING NAME RINK FLOOR DETAILS	
CLIENT SPRINGFIELD PARK DISTRICT	
PROJECT SPRINGFIELD - PLANT REPLACEMENT	
DRAWN BY V.KOFANOV	CHECKED BY J. RITCHIE
DATE 05-SEP-24	REVISION 4.0
SHEET SIZE C	SHEET NO. 10 OF 10

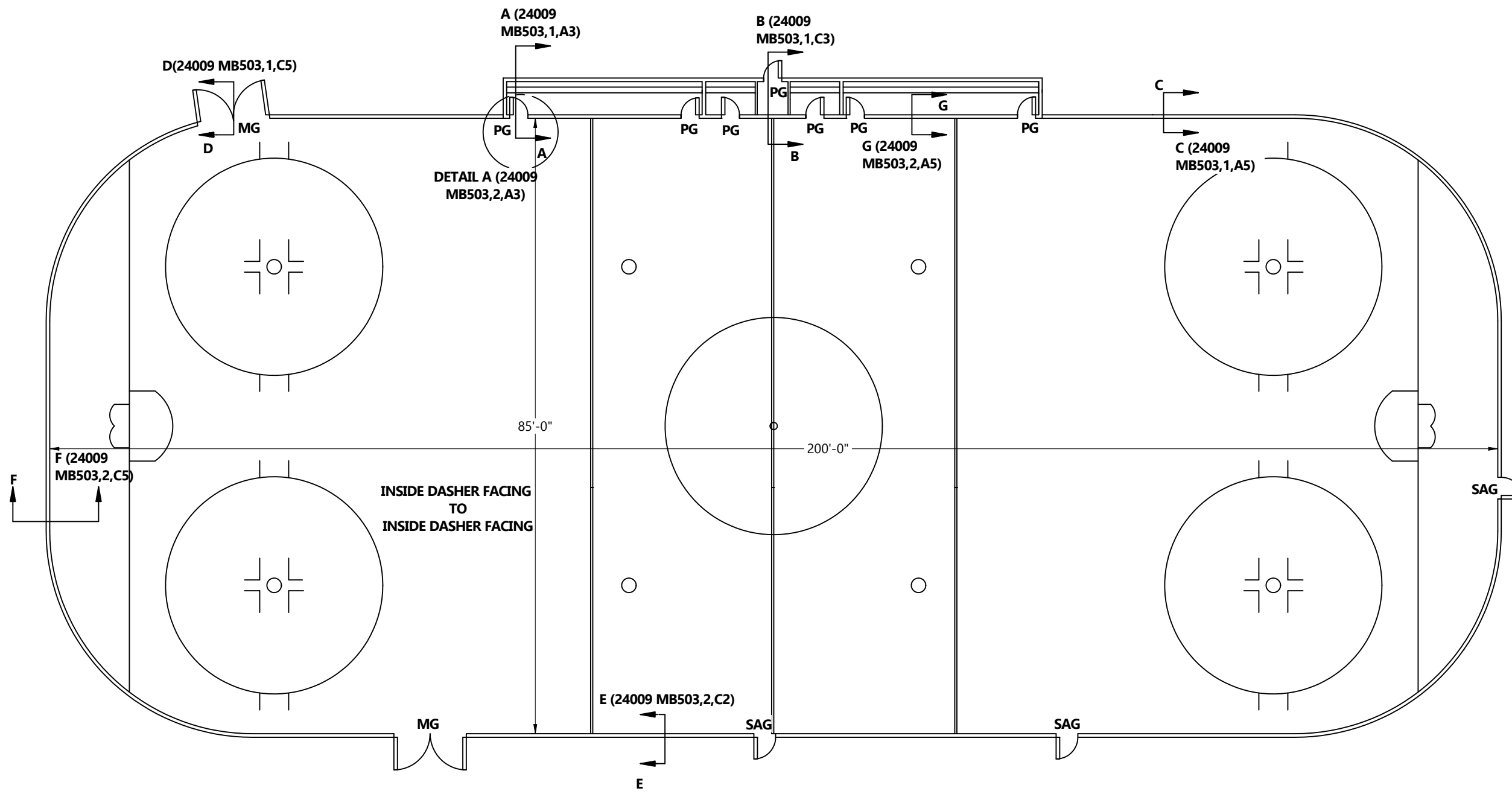
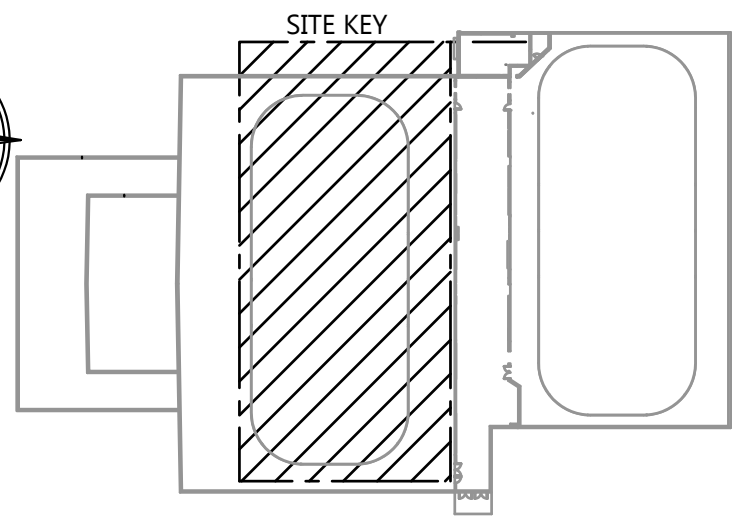
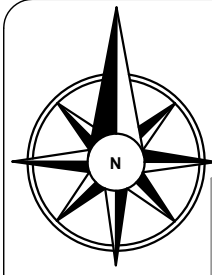

RINK 1 BOARDS & GLASS PLAN
SCALE 1/16"=1'-0"

GATE DETAILS			
QTY.	CODE	ITEM	DIMENSION
7	PG	PLAYER GATE	30"
3	SAG	SINGLE ACCESS GATE	36"
2	MG	MACHINE GATE	120"(2X60)

BOX INSIDE DIMENSIONS		
TYPE	LENGTH	WIDTH
PLAYER'S BOX (RIGHT)	27'	55"
PLAYER'S BOX (LEFT)	27'	55"
PENALTY BOX (RIGHT)	82"	55"
PENALTY BOX (LEFT)	82"	55"
TIMEKEEPER'S BOX	51"	55"

- NOTES:**
- ALL DIMENSIONS TO BE CONFIRMED DURING BOARDS & GLASS SITE SURVEY
 - ALL GATE LOCATIONS TO BE CONFIRMED DURING BOARDS & GLASS SITE SURVEY

RINK 1 BOARDS & GLASS PLAN

NOTES

---	NEW
---	EXISTING

REFERENCE DEFINITION	
SHEET COLUMN	SHEET ROW
---	(#, X#)

COPYRIGHT AND DISCLAIMER
THIS WORK IS THE SOLE PROPERTY OF I.B. STOREY INC AND IS INTENDED SOLELY FOR THE INFORMATION OF THE CLIENT. ALL RIGHTS RESERVED. THE WORK MAY NOT BE REPRODUCED OR DISTRIBUTED, WHOLE OR IN PART, WITHOUT THE PRIOR WRITTEN PERMISSION OF I.B. STOREY INC.
THIS DOCUMENT MAY NOT BE USED FOR ANY OTHER PROJECTS OR WITHOUT INVOLVEMENT OF I.B. STOREY INC. ANY USE WHICH A THIRD PARTY MAKES OF THE WORK, OR ANY RELIANCE ON OR DECISIONS TO BE MADE BASED ON IT, ARE THE RESPONSIBILITY OF SUCH THIRD PARTIES.

- NOT FOR CONSTRUCTION -
CONFIDENTIAL & PROPRIETARY

VER #	REVISIONS	DATE	BY
2.0	ISSUED FOR DETAILED DESIGN	05-SEP-24	V.K.
1.0	ISSUED FOR SCHEMATIC DESIGN	28-JUN-24	H.D.



CHARLOTTETOWN PE
VAUGHAN ON
REDINGTON SHORES FL
PLANO TX

WWW.IBSTOREY.COM

STAMP	

DRAWING NUMBER 24009 MB101	
DRAWING NAME BOARDS AND GLASS PLAN	
CLIENT SPRINGFIELD PARK DISTRICT	
PROJECT SPRINGFIELD-PLANT REPLACEMENT	
DRAWN BY V.KOFANOV	CHECKED BY J.RITCHIE
DATE 05-SEP-24	REVISION 2.0
SHEET SIZE C	SHEET NO. 1 OF 3

23020 MB101

NOTES

---	NEW
---	EXISTING

REFERENCE DEFINITION	
SHEET COLUMN	SHEET ROW
SHEET NUMBER	(#, X#)

COPYRIGHT AND DISCLAIMER

THIS WORK IS THE SOLE PROPERTY OF I.B. STOREY INC AND IS INTENDED SOLELY FOR THE INFORMATION OF THE CLIENT. ALL RIGHTS RESERVED. THE WORK MAY NOT BE REPRODUCED OR DISTRIBUTED, WHOLE OR IN PART, WITHOUT THE PRIOR WRITTEN PERMISSION OF I.B. STOREY INC. THIS DOCUMENT MAY NOT BE USED FOR ANY OTHER PROJECTS OR WITHOUT INVOLVEMENT OF I.B. STOREY INC. ANY USE WHICH A THIRD PARTY MAKES OF THE WORK, OR ANY RELIANCE ON OR DECISIONS TO BE MADE BASED ON IT, ARE THE RESPONSIBILITY OF SUCH THIRD PARTIES.

- NOT FOR CONSTRUCTION -
CONFIDENTIAL & PROPRIETARY

VER #	REVISIONS	DATE	BY
2.0	ISSUED FOR DETAILED DESIGN	05-SEP-24	V.K.
1.0	ISSUED FOR SCHEMATIC DESIGN	28-JUN-24	H.D.



CHARLOTTETOWN PE
VAUGHAN ON
REDINGTON SHORES FL
PLANO TX

WWW.IBSTOREY.COM

STAMP	

DRAWING NUMBER		24009 MB101
DRAWING NAME		BOARDS AND GLASS PLAN
CLIENT		SPRINGFIELD PARK DISTRICT
PROJECT		SPRINGFIELD-PLANT REPLACEMENT
DRAWN BY	CHECKED BY	
V.KOFANOV	J.RITCHIE	
DATE	REVISION	
05-SEP-24	2.0	
SHEET SIZE	SHEET NO.	
C	2 OF 3	

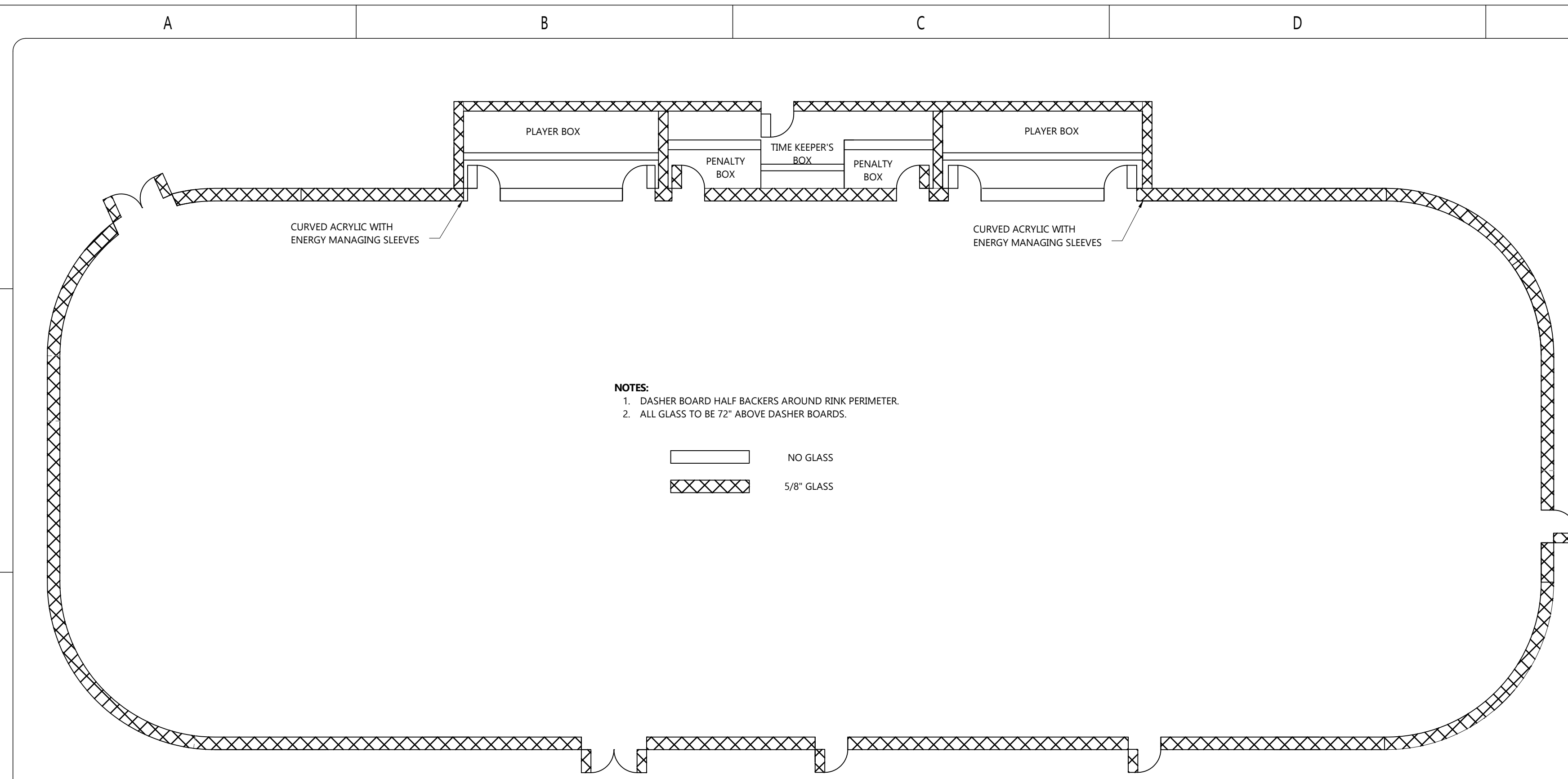

- NOTES:**
- DASHER BOARD HALF BACKERS AROUND RINK PERIMETER.
 - ALL GLASS TO BE 72" ABOVE DASHER BOARDS.

	NO GLASS
	5/8" GLASS

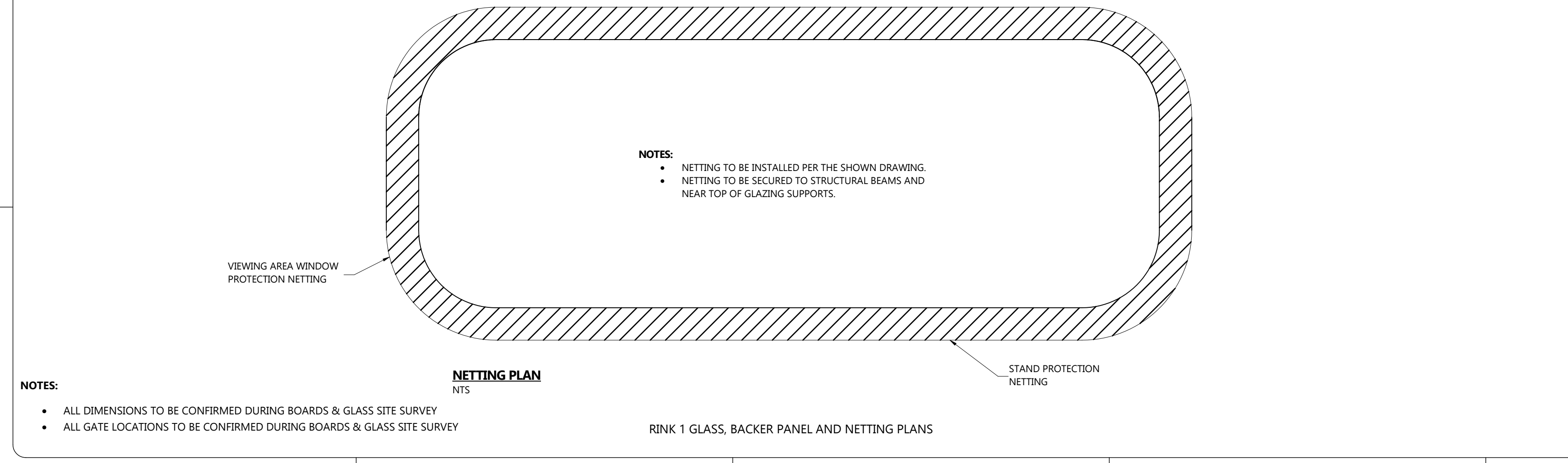

- NOTES:**
- ALL DIMENSIONS TO BE CONFIRMED DURING BOARDS & GLASS SITE SURVEY
 - ALL GATE LOCATIONS TO BE CONFIRMED DURING BOARDS & GLASS SITE SURVEY

RINK 1 GLASS, BACKER PANEL AND NETTING PLANS

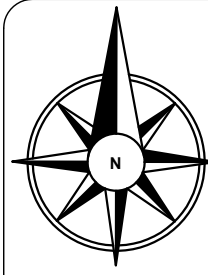

SITE KEY

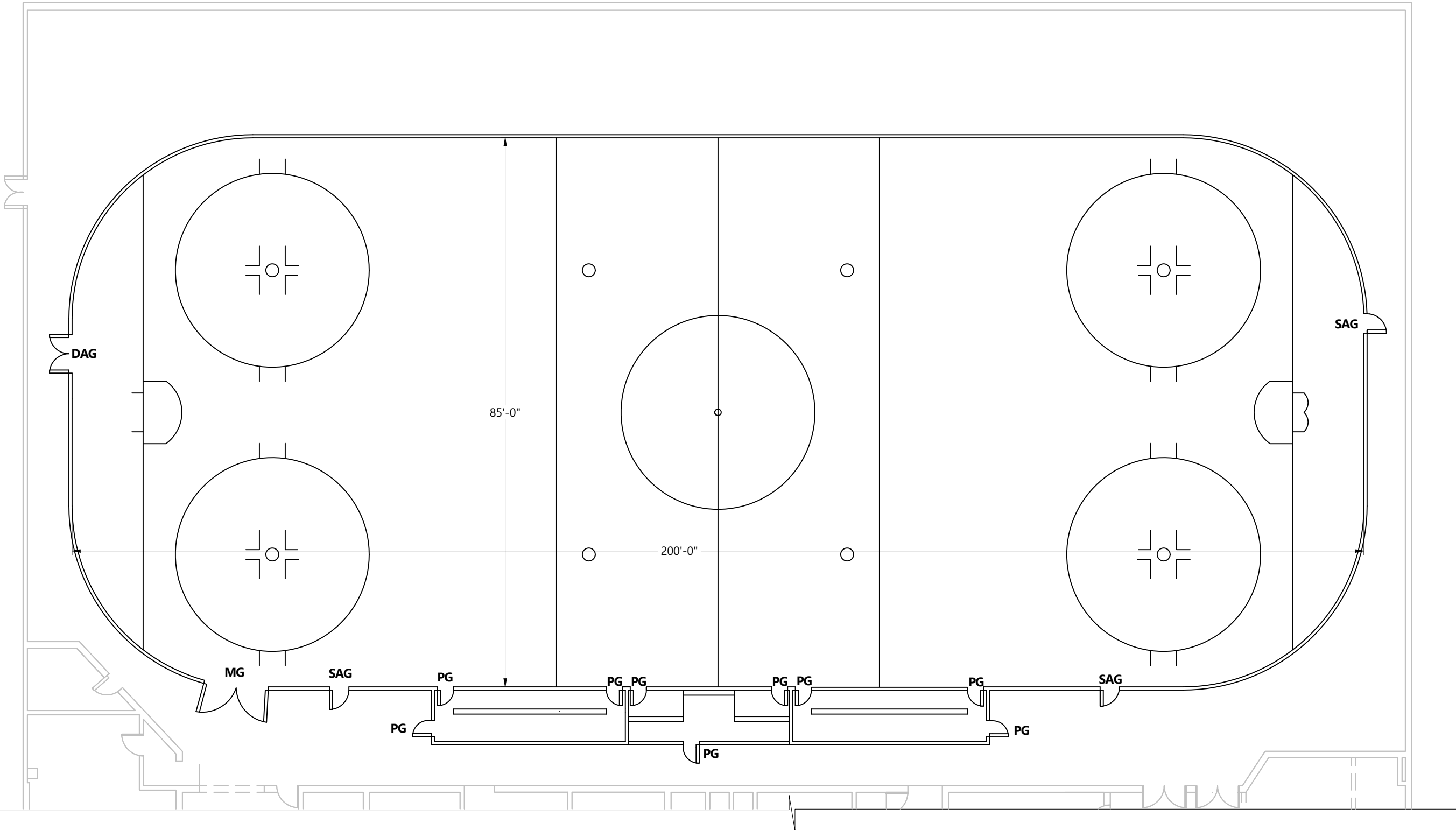
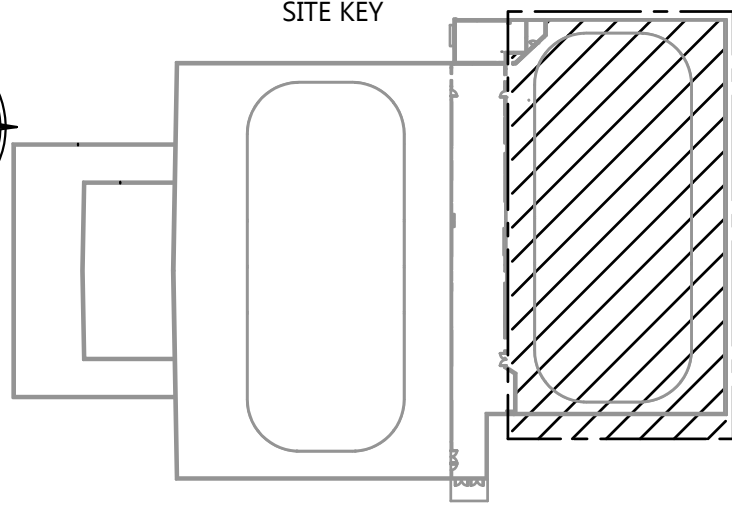

RINK 2 BOARDS & GLASS PLAN
SCALE 1/16"=1'-0"

GATE DETAILS		
QTY.	CODE	ITEM
9	PG	PLAYER GATE
3	SAG	SINGLE ACCESS GATE
1	DAG	DOUBLE ACCESS GATE
1	MG	MACHINE GATE

RINK 2 BOARDS & GLASS PLAN

NOTES

- CONTRACTOR TO SURVEY FOR ANCHOR LOCATIONS AND COORDINATE WITH RINK FLOOR INSTALLATION
- CONTRACTOR TO SURVEY FOR DOOR/GATE LOCATIONS
- RINK 2 EXISTING BOARDS AND GLASS TO BE REMOVED, STORED AND RE-INSTALLED

NOTES

---	NEW
---	EXISTING

REFERENCE DEFINITION	
SHEET COLUMN	SHEET ROW
SHEET NUMBER	(#, X#)

COPYRIGHT AND DISCLAIMER
THIS WORK IS THE SOLE PROPERTY OF I.B. STOREY INC AND IS INTENDED SOLELY FOR THE INFORMATION OF THE CLIENT. ALL RIGHTS RESERVED. THE WORK MAY NOT BE REPRODUCED OR DISTRIBUTED, WHOLE OR IN PART, WITHOUT THE PRIOR WRITTEN PERMISSION OF I.B. STOREY INC.
THIS DOCUMENT MAY NOT BE USED FOR ANY OTHER PROJECTS OR WITHOUT INVOLVEMENT OF I.B. STOREY INC. ANY USE WHICH A THIRD PARTY MAKES OF THE WORK, OR ANY RELIANCE ON OR DECISIONS TO BE MADE BASED ON IT, ARE THE RESPONSIBILITY OF SUCH THIRD PARTIES.

- NOT FOR CONSTRUCTION -
CONFIDENTIAL & PROPRIETARY

VER #	REVISIONS	DATE	BY
2.0	ISSUED FOR DETAILED DESIGN	05-SEP-24	V.K.
1.0	ISSUED FOR SCHEMATIC DESIGN	28-JUN-24	H.D.



CHARLOTTETOWN PE
VAUGHAN ON
REDINGTON SHORES FL
PLANO TX

WWW.IBSTOREY.COM

STAMP

DRAWING NUMBER 24009 MB101	
DRAWING NAME BOARDS AND GLASS PLAN	
CLIENT SPRINGFIELD PARK DISTRICT	
PROJECT SPRINGFIELD-PLANT REPLACEMENT	
DRAWN BY V.KOFANOV	CHECKED BY J.RITCHIE
DATE 05-SEP-24	REVISION 2.0
SHEET SIZE C	SHEET NO. 3 OF 3

23020 MB101

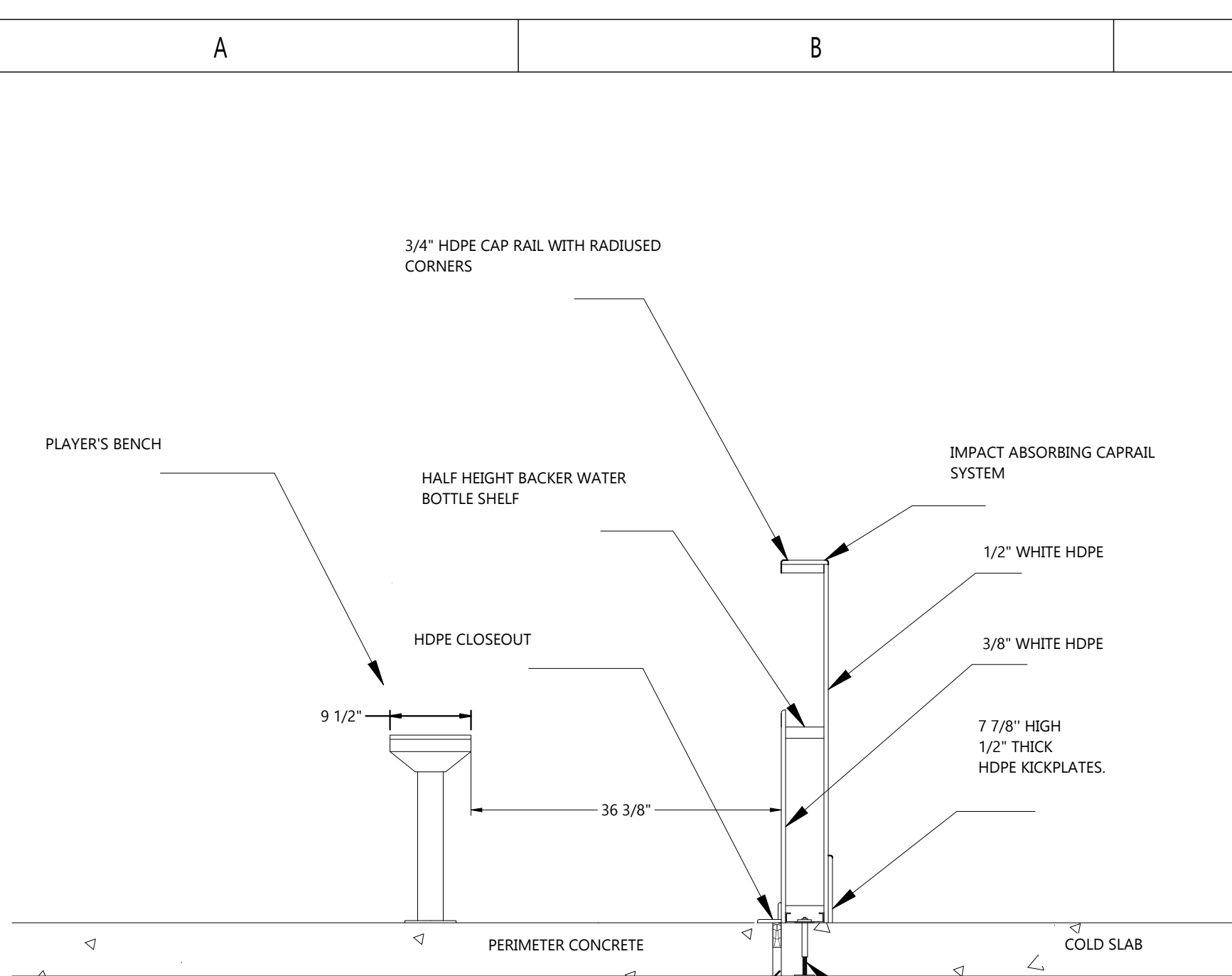

SECTION CUT A-A (24009 MB101,1,B2) 90°: PLAYERS BENCH DETAILS
SCALE 1/2" = 1'-0"

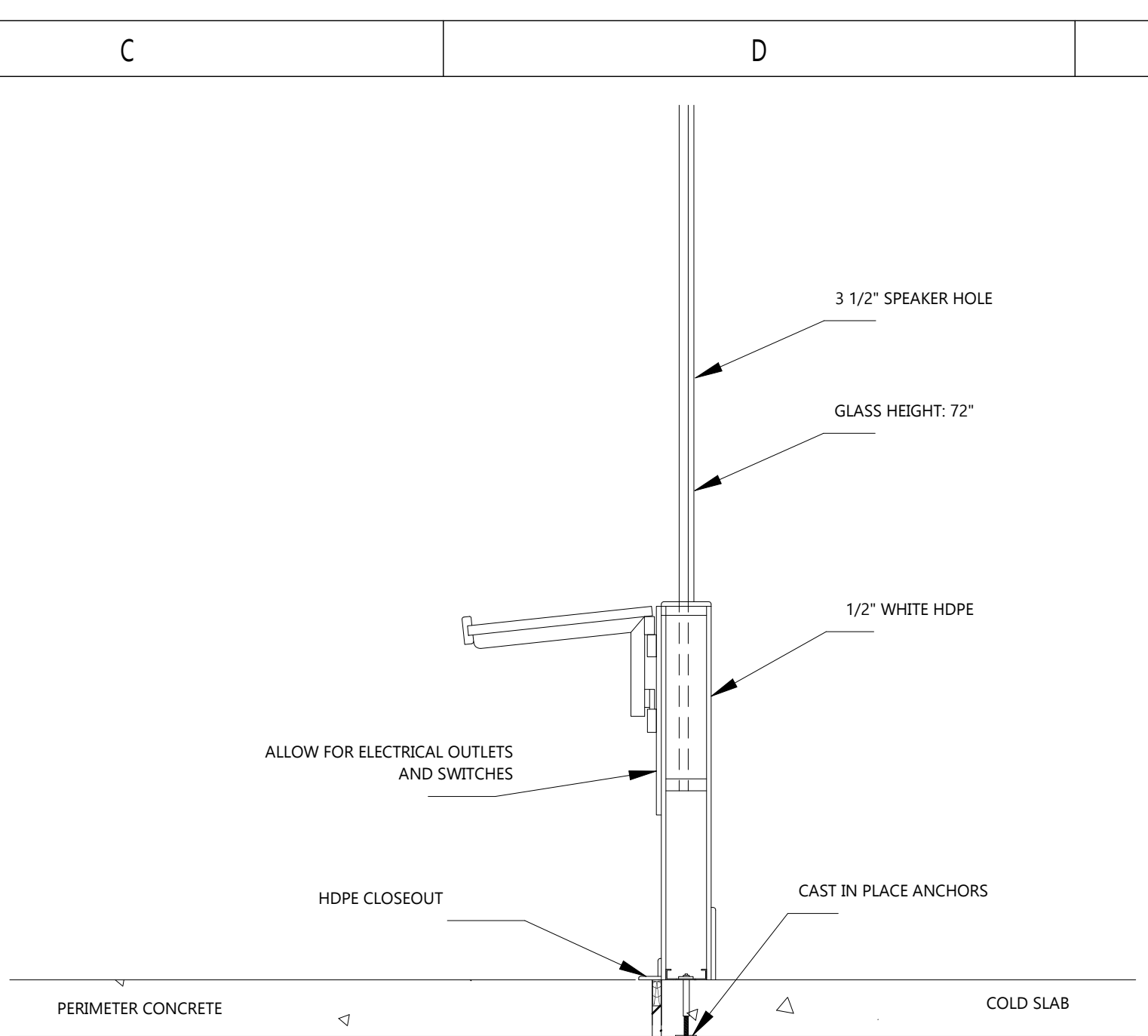

SECTION CUT B-B (24009 MB101,1,C2) 90°: TIME KEEPER'S BOX DETAILS
SCALE 1/2" = 1'-0"

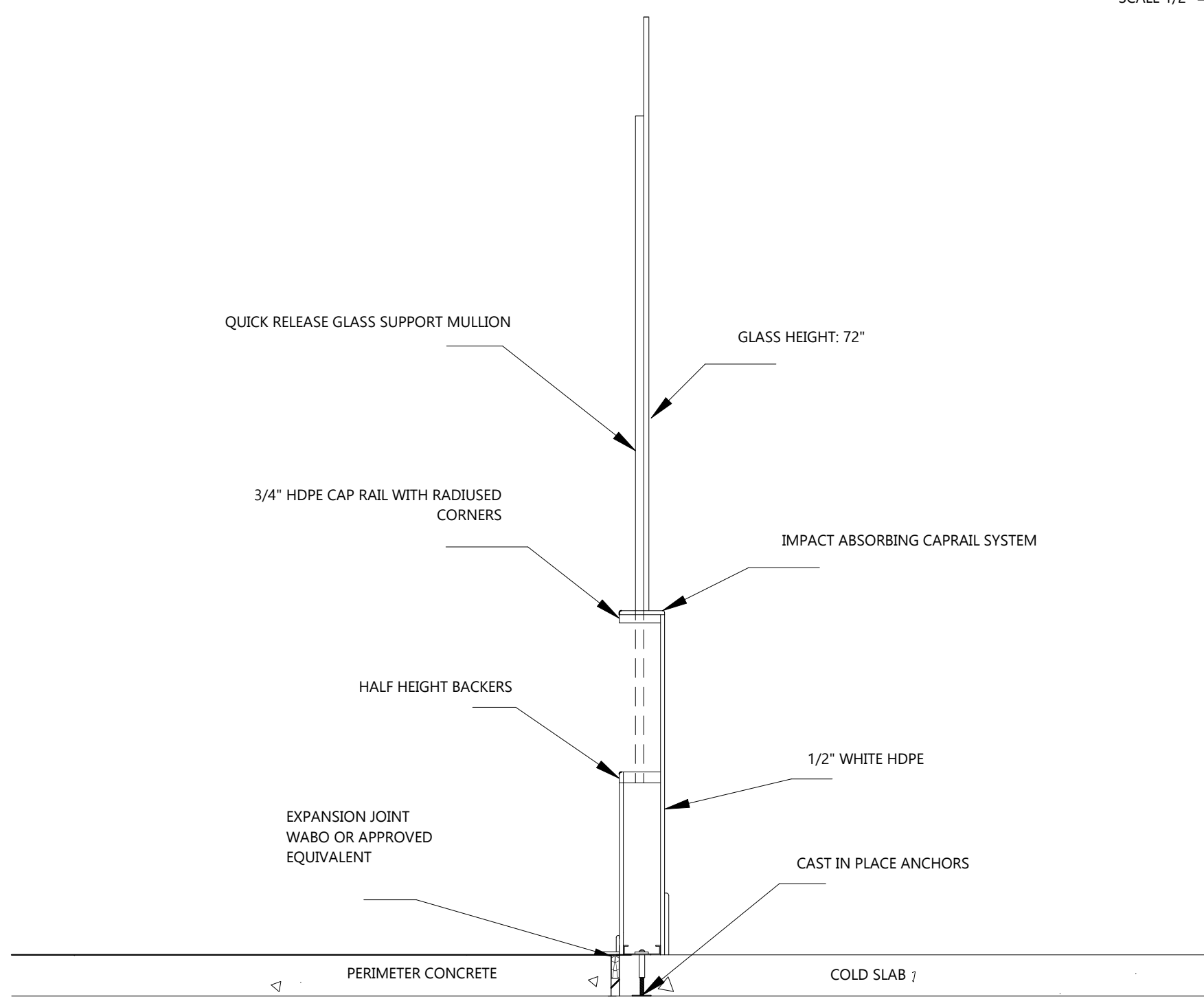

SECTION CUT C-C (24009 MB101,1,D2) 90°: HALF HEIGHT BACKER SECTION
SCALE 1/2" = 1'-0"

DASHER BOARD DETAILS - 1

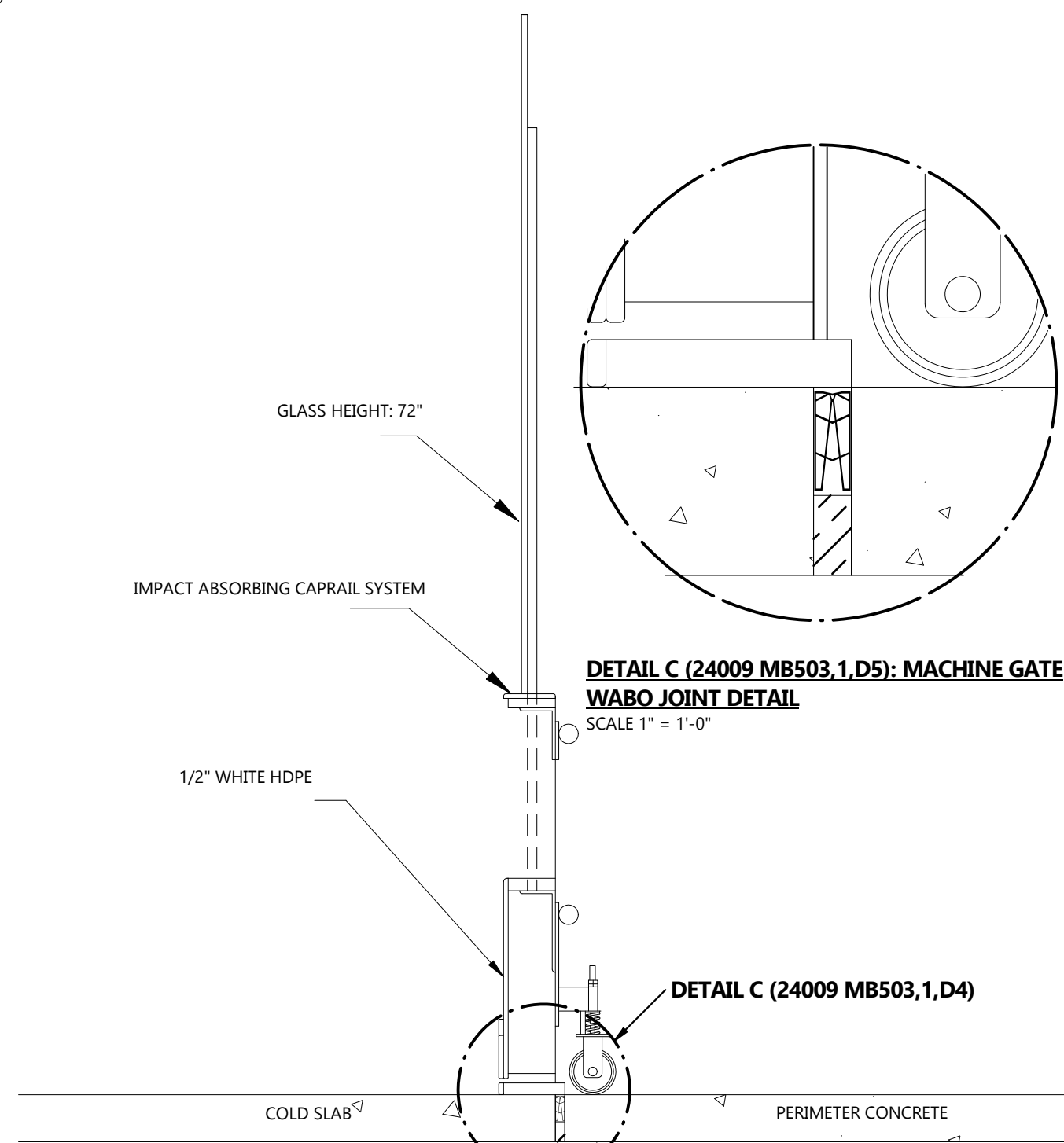

SECTION CUT D-D (24009 MB101,1,B2) 90°: MACHINE GATE DETAILS
SCALE 1/2" = 1'-0"

DETAIL C (24009 MB503,1,D5): MACHINE GATE WABO JOINT DETAIL
SCALE 1" = 1'-0"

DETAIL C (24009 MB503,1,D4)

NOTES

---	NEW
---	EXISTING

REFERENCE DEFINITION

SHEET COLUMN	SHEET ROW
(#, X#)	

COPYRIGHT AND DISCLAIMER
THIS WORK IS THE SOLE PROPERTY OF I.B. STOREY INC AND IS INTENDED SOLELY FOR THE INFORMATION OF THE CLIENT. ALL RIGHTS RESERVED. THE WORK MAY NOT BE REPRODUCED OR DISTRIBUTED, WHOLE OR IN PART, WITHOUT THE PRIOR WRITTEN PERMISSION OF I.B. STOREY INC.
THIS DOCUMENT MAY NOT BE USED FOR ANY OTHER PROJECTS OR WITHOUT INVOLVEMENT OF I.B. STOREY INC. ANY USE WHICH A THIRD PARTY MAKES OF THE WORK, OR ANY RELIANCE ON OR DECISIONS TO BE MADE BASED ON IT, ARE THE RESPONSIBILITY OF SUCH THIRD PARTIES.

- NOT FOR CONSTRUCTION -
CONFIDENTIAL & PROPRIETARY

VER #	REVISIONS	DATE	BY
4.0	ISSUED FOR DETAILED DESIGN	05-SEP-24	V.K.
3.0	ISSUED FOR SCHEMATIC DESIGN	28-JUN-24	H.D.
2.0	ISSUED FOR CONCEPTUAL DESIGN	29-MAY-24	E.K.
1.0	ISSUED FOR WORKSHOP	06-MAY-24	V.K.

I.B. STOREY
Rink Engineering Experts

CHARLOTTETOWN PE
VAUGHAN ON
REDINGTON SHORES FL
PLANO TX

WWW.IBSTOREY.COM

STAMP

DRAWING NUMBER	24009 MB503
DRAWING NAME	BOARDS AND GLASS DETAILS
CLIENT	SPRINGFIELD PARK DISTRICT
PROJECT	SPRINGFIELD-PLANT REPLACEMENT
DRAWN BY	V.KOFANOV
CHECKED BY	J.RITCHIE
DATE	05-SEP-24
REVISION	4.0
SHEET SIZE	C
SHEET NO.	1 OF 2

24009 MB503

1

2

3

4

5

A

B

C

D

E

A

B

C

D

E

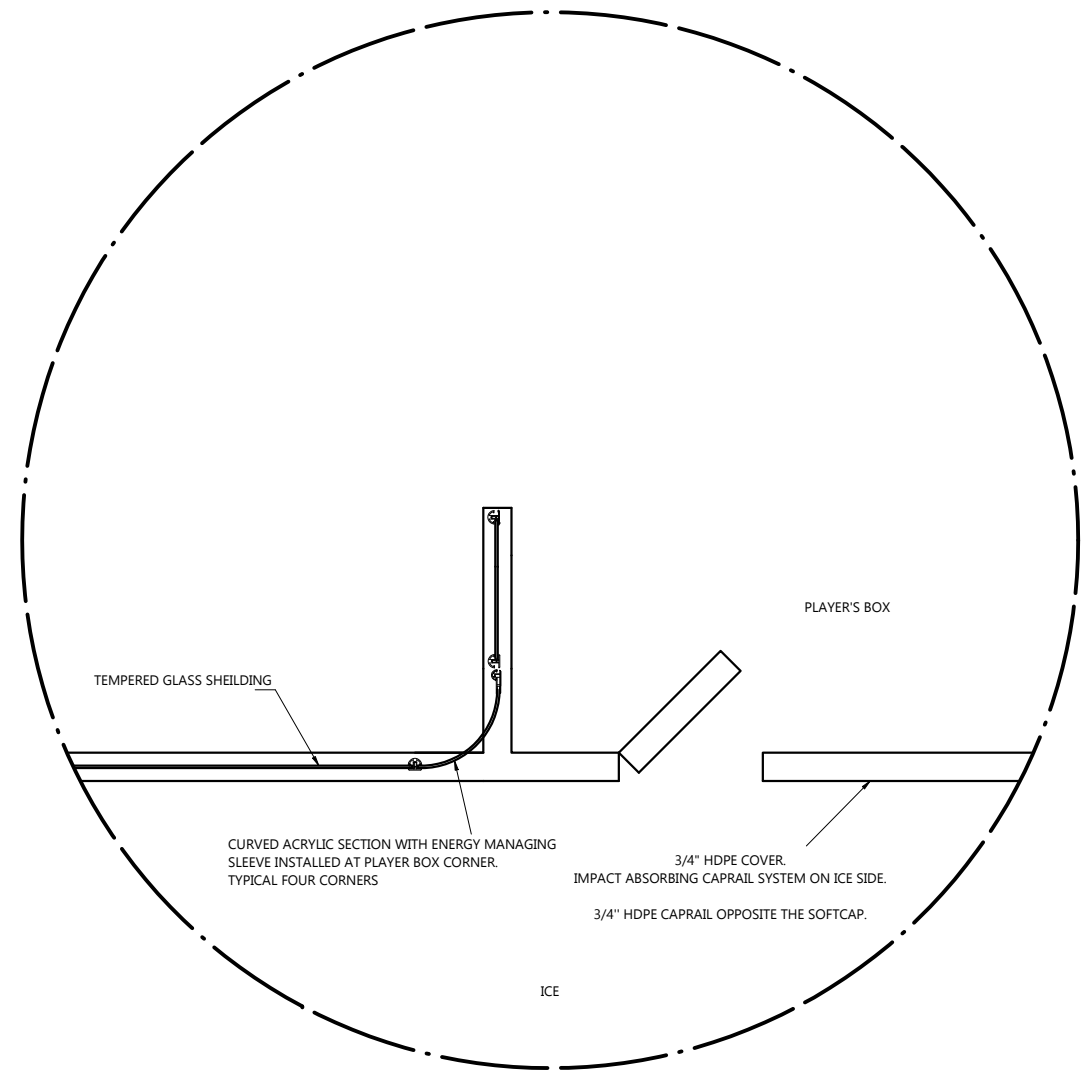

DETAIL A (24009 MB101,1,B2): CURVED ACRYLIC DETAIL
 NTS

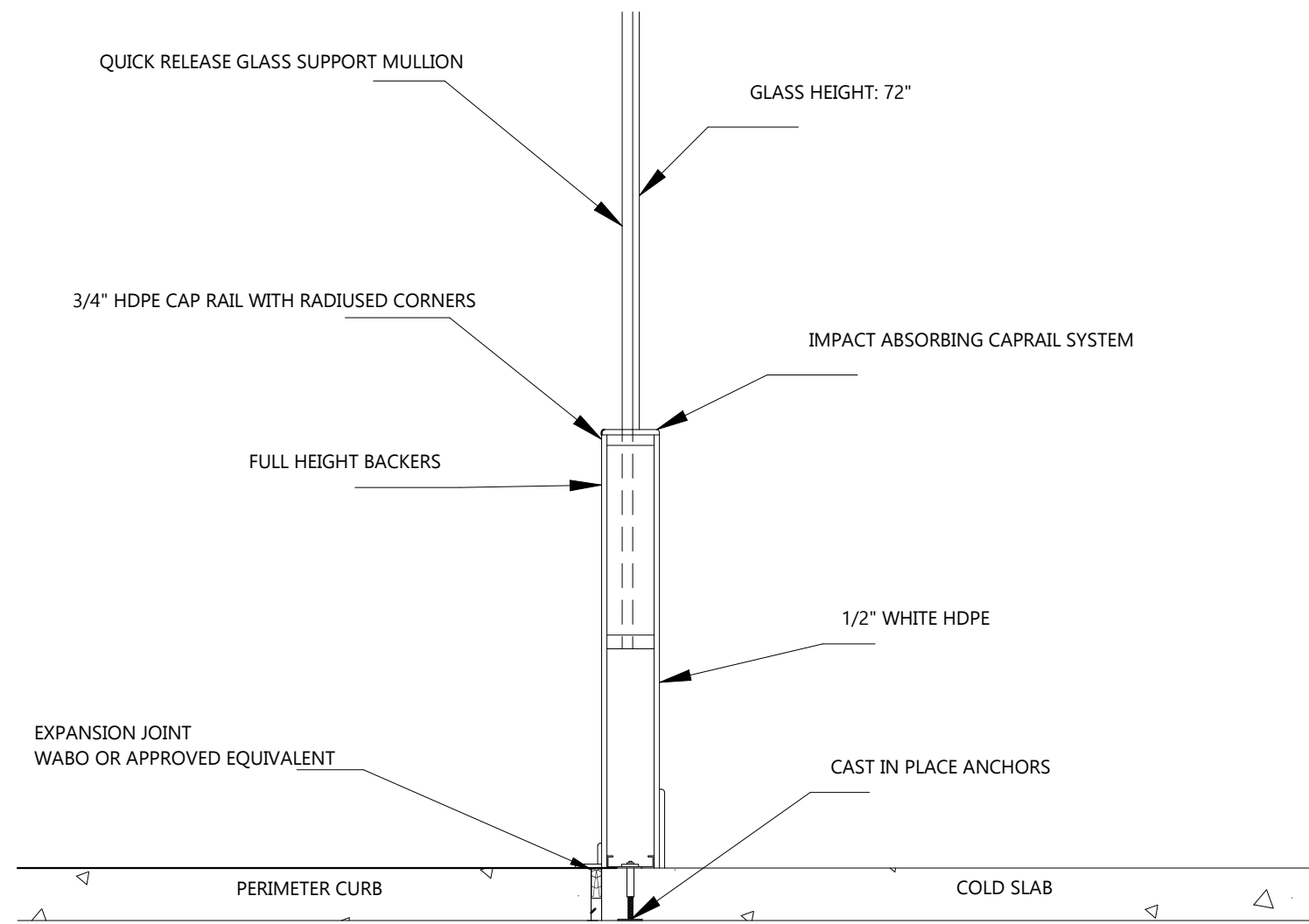

SECTION CUT E-E (24009 MB101,1,B4) 90°: FULL BACKER SECTION
 SCALE 1/2" = 1'-0"

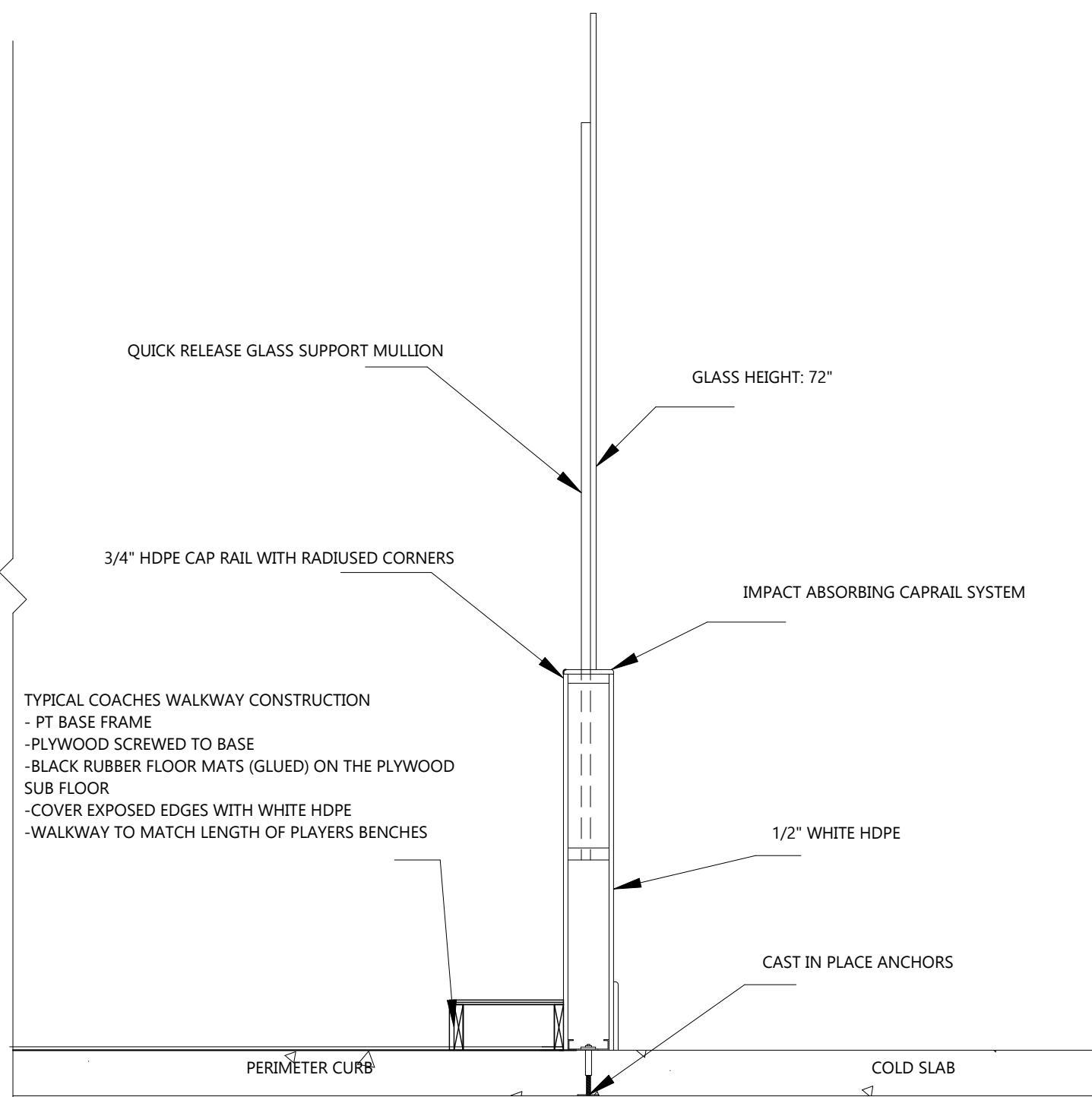

SECTION CUT G-G(24009 MB101,1,C2) 90°: PLAYER BOX GATE SECTION
 SCALE 1/2" = 1'-0"

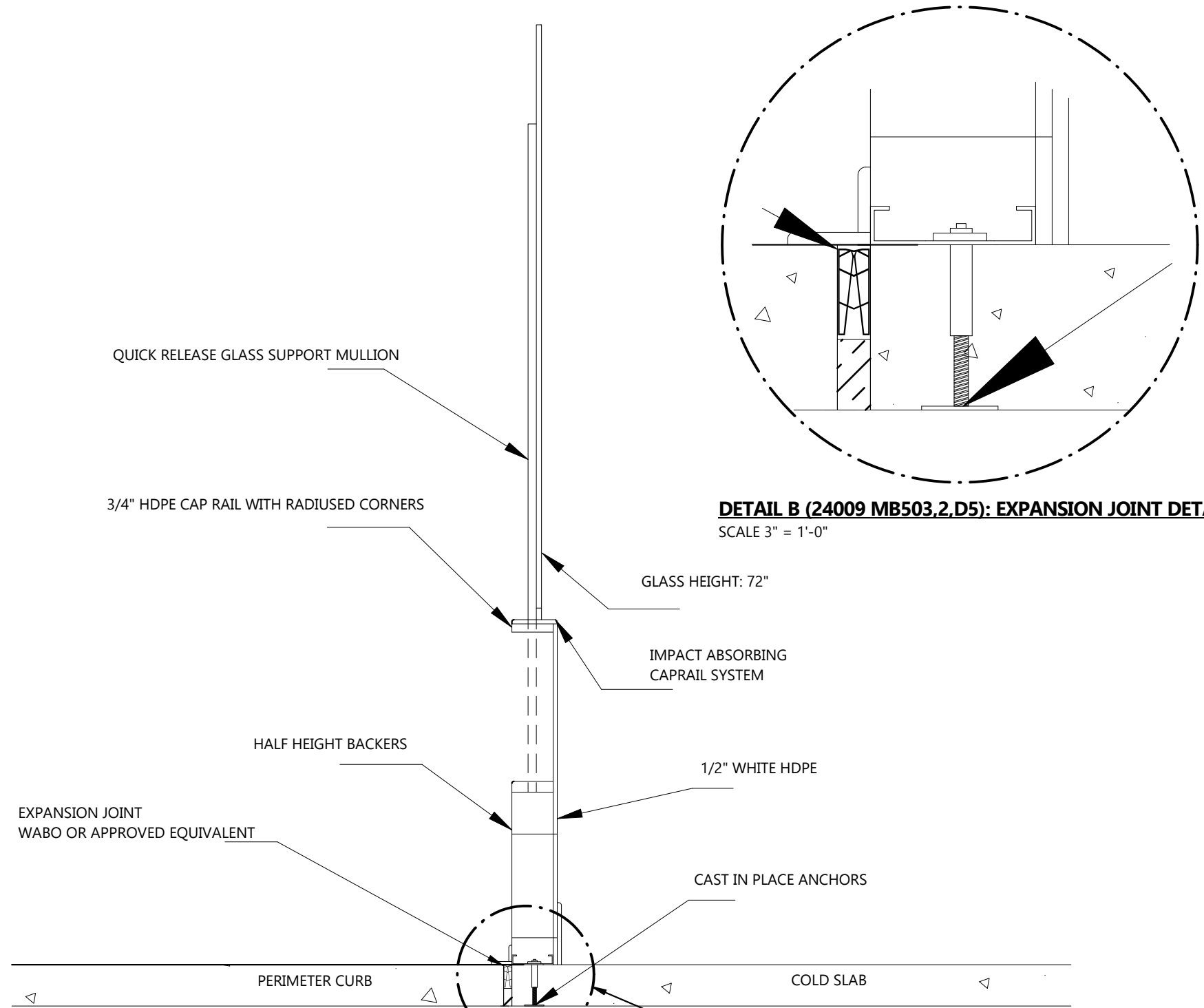

SECTION CUT F-F(24009 MB101,1,A3): HALF BACKER SECTION
 SCALE 1/2" = 1'-0"

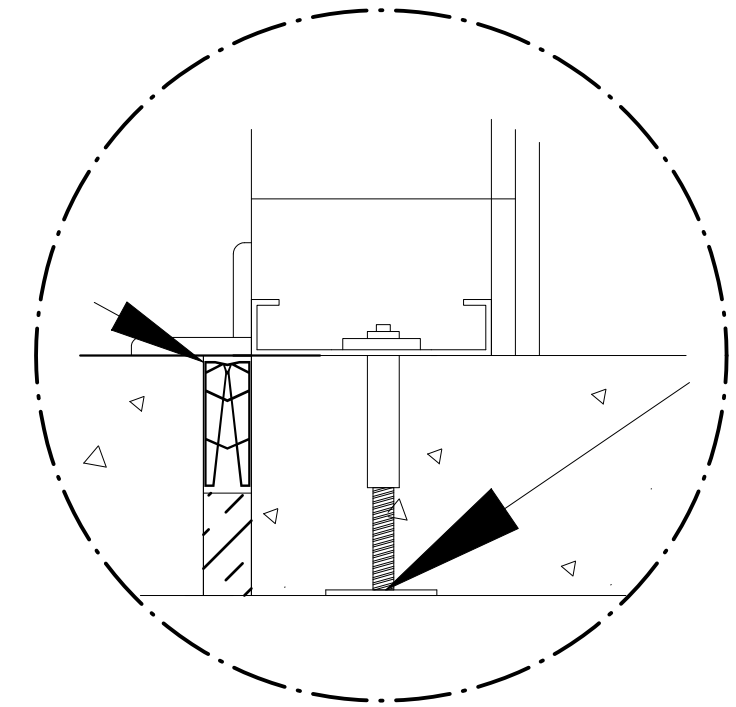

DETAIL B (24009 MB503,2,D5): EXPANSION JOINT DETAIL
 SCALE 3" = 1'-0"

DETAIL B (24009 MB503,2,D4)

NOTES

---	NEW
---	EXISTING

REFERENCE DEFINITION	
SHEET COLUMN	SHEET ROW
(#, X#)	

COPYRIGHT AND DISCLAIMER
 THIS WORK IS THE SOLE PROPERTY OF I.B. STOREY INC AND IS INTENDED SOLELY FOR THE INFORMATION OF THE CLIENT. ALL RIGHTS RESERVED. THE WORK MAY NOT BE REPRODUCED OR DISTRIBUTED, WHOLE OR IN PART, WITHOUT THE PRIOR WRITTEN PERMISSION OF I.B. STOREY INC.
 THIS DOCUMENT MAY NOT BE USED FOR ANY OTHER PROJECTS OR WITHOUT INVOLVEMENT OF I.B. STOREY INC. ANY USE WHICH A THIRD PARTY MAKES OF THE WORK, OR ANY RELIANCE ON OR DECISIONS TO BE MADE BASED ON IT, ARE THE RESPONSIBILITY OF SUCH THIRD PARTIES.

- NOT FOR CONSTRUCTION -
 CONFIDENTIAL & PROPRIETARY

VER #	REVISIONS	DATE	BY
4.0	ISSUED FOR DETAILED DESIGN	05-SEP-24	V.K.
3.0	ISSUED FOR SCHEMATIC DESIGN	28-JUN-24	H.D.
2.0	ISSUED FOR CONCEPTUAL DESIGN	29-MAY-24	E.K.
1.0	ISSUED FOR WORKSHOP	06-MAY-24	V.K.

I.B. STOREY
 Rink Engineering Experts
 CHARLOTTETOWN PE
 VAUGHAN ON
 REDINGTON SHORES FL
 PLANO TX
 WWW.IBSTOREY.COM

DRAWING NUMBER		24009 MB503	
DRAWING NAME		BOARDS AND GLASS DETAILS	
CLIENT		SPRINGFIELD PARK DISTRICT	
PROJECT		SPRINGFIELD-PLANT REPLACEMENT	
DRAWN BY	V.KOFANOV	CHECKED BY	J.RITCHIE
DATE	05-SEP-24	REVISION	4.0
SHEET SIZE	C	SHEET NO.	2 OF 2

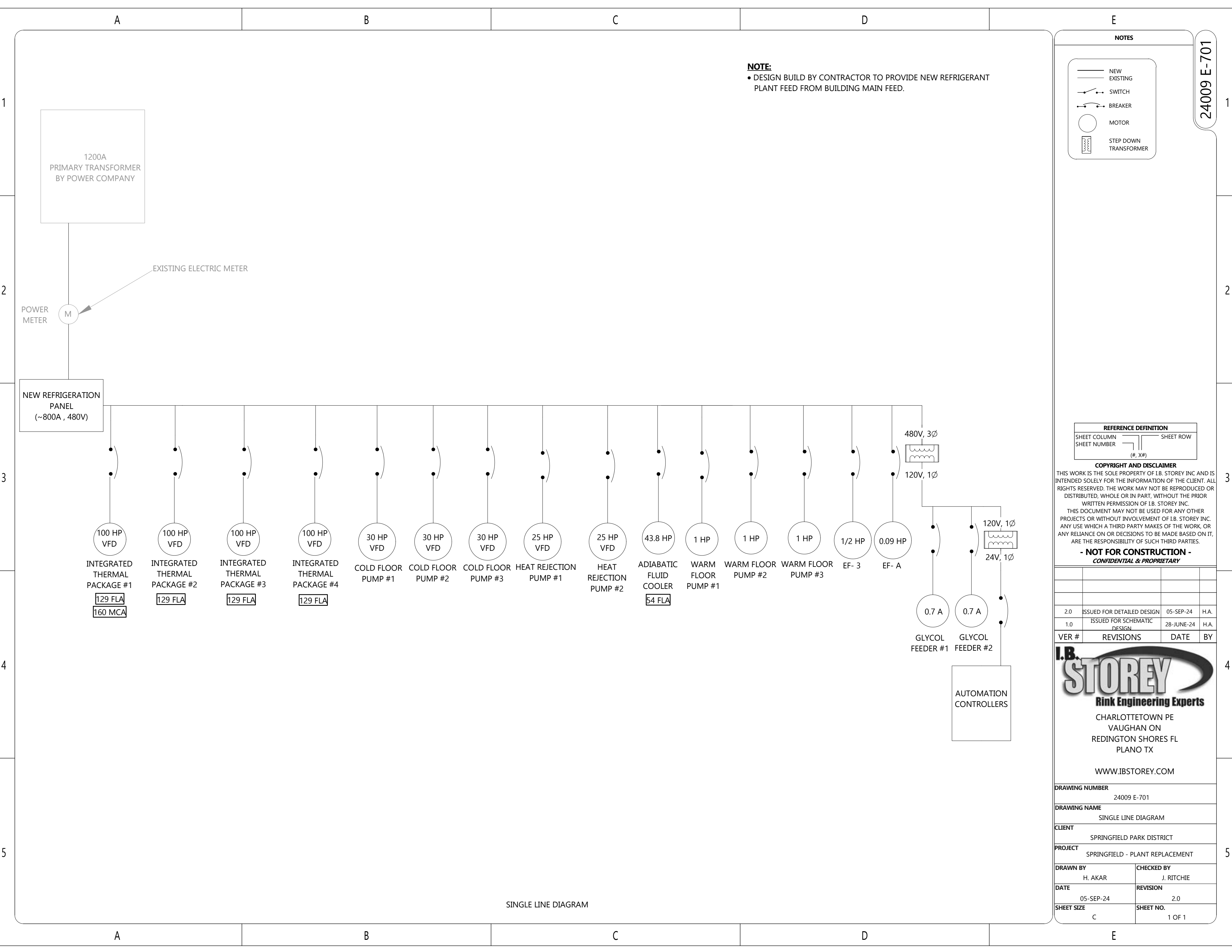

NOTE:
 • DESIGN BUILD BY CONTRACTOR TO PROVIDE NEW REFRIGERANT PLANT FEED FROM BUILDING MAIN FEED.

NOTES

- NEW
- - - EXISTING
- ⏏ SWITCH
- ⏏ BREAKER
- ⊙ MOTOR
- ⏏ STEP DOWN TRANSFORMER

24009 E-701

REFERENCE DEFINITION

SHEET COLUMN	SHEET ROW
(#, X#)	(#, X#)

COPYRIGHT AND DISCLAIMER
 THIS WORK IS THE SOLE PROPERTY OF I.B. STOREY INC AND IS INTENDED SOLELY FOR THE INFORMATION OF THE CLIENT. ALL RIGHTS RESERVED. THE WORK MAY NOT BE REPRODUCED OR DISTRIBUTED, WHOLE OR IN PART, WITHOUT THE PRIOR WRITTEN PERMISSION OF I.B. STOREY INC. THIS DOCUMENT MAY NOT BE USED FOR ANY OTHER PROJECTS OR WITHOUT INVOLVEMENT OF I.B. STOREY INC. ANY USE WHICH A THIRD PARTY MAKES OF THE WORK, OR ANY RELIANCE ON OR DECISIONS TO BE MADE BASED ON IT, ARE THE RESPONSIBILITY OF SUCH THIRD PARTIES.

- NOT FOR CONSTRUCTION -
 CONFIDENTIAL & PROPRIETARY

VER #	REVISIONS	DATE	BY
2.0	ISSUED FOR DETAILED DESIGN	05-SEP-24	H.A.
1.0	ISSUED FOR SCHEMATIC DESIGN	28-JUNE-24	H.A.

I.B. STOREY
 Risk Engineering Experts
 CHARLOTTETOWN PE
 VAUGHAN ON
 REDINGTON SHORES FL
 PLANO TX
 WWW.IBSTOREY.COM

DRAWING NUMBER	24009 E-701
DRAWING NAME	SINGLE LINE DIAGRAM
CLIENT	SPRINGFIELD PARK DISTRICT
PROJECT	SPRINGFIELD - PLANT REPLACEMENT
DRAWN BY	H. AKAR
CHECKED BY	J. RITCHIE
DATE	05-SEP-24
REVISION	2.0
SHEET SIZE	C
SHEET NO.	1 OF 1

SINGLE LINE DIAGRAM

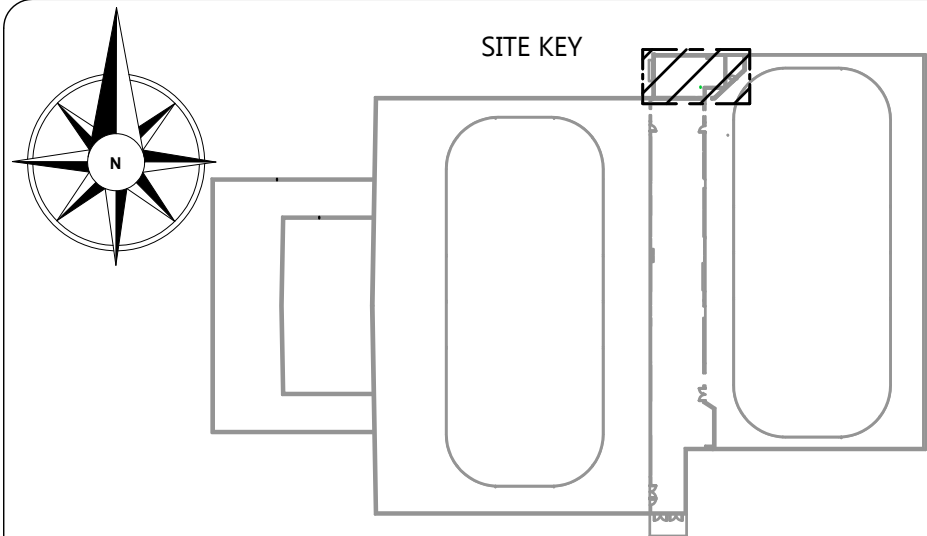

PLANT ROOM PHYSICAL LOADS			
TAG	DESCRIPTION	WEIGHT (LBS)	NOTES
ITP-1	ICE REFRIGERATION PKG	5,587	-
ITP-2	ICE REFRIGERATION PKG	5,587	-
ITP-3	ICE REFRIGERATION PKG	5,587	-
ITP-4	ICE REFRIGERATION PKG	5,587	-
CP-1	COLD FLOOR PUMP	1,334	-
CP-2	COLD FLOOR PUMP	1,334	-
CP-3	COLD FLOOR PUMP	1,334	-
HP-1	CONDENSER PUMP	941	-
HP-2	CONDENSER PUMP	941	-
WFP-1	WARM FLOOR PUMP	164.1	-
WFP-2	WARM FLOOR PUMP	164.1	-
WFP-3	WARM FLOOR PUMP	164.1	-

PLANT ROOM PHYSICAL LOADS			
TAG	DESCRIPTION	WEIGHT (LBS)	NOTES
SP-1	SUMP PUMP	818	-
ST-1	SUMP TANK	-	-
EXP-1	COLD SIDE EXPANSION TANK	651	-
EXP-2	WARM SIDE EXPANSION TANK	191	-
ASP-1	COLD SIDE AIR SEPERATOR	390	SUSPENDED
ASP-2	WARM SIDE AIR SEPERATOR	228	SUSPENDED
SF-1	COLD SIDE STREAM FILTER	144	-
SF-2	WARM SIDE STREAM FILTER	14	PIPE MOUNTED
GF-1	COLD SIDE GLYCOL FEEDER	983	-
GF-2	WARM SIDE GLYCOL FEEDER	983	-
HS-1	WARM FLOOR HYDRAULIC SEPERATOR	121	SUSPENDED

NOTES

NEW
EXISTING

REFERENCE DEFINITION

SHEET COLUMN	SHEET ROW
(#, X#)	

COPYRIGHT AND DISCLAIMER
 THIS WORK IS THE SOLE PROPERTY OF I.B. STOREY INC AND IS INTENDED SOLELY FOR THE INFORMATION OF THE CLIENT. ALL RIGHTS RESERVED. THE WORK MAY NOT BE REPRODUCED OR DISTRIBUTED, WHOLE OR IN PART, WITHOUT THE PRIOR WRITTEN PERMISSION OF I.B. STOREY INC.
 THIS DOCUMENT MAY NOT BE USED FOR ANY OTHER PROJECTS OR WITHOUT INVOLVEMENT OF I.B. STOREY INC. ANY USE WHICH A THIRD PARTY MAKES OF THE WORK, OR ANY RELIANCE ON OR DECISIONS TO BE MADE BASED ON IT, ARE THE RESPONSIBILITY OF SUCH THIRD PARTIES.

- NOT FOR CONSTRUCTION -
CONFIDENTIAL & PROPRIETARY

1.0	ISSUED FOR DETAILED DESIGN	05-SEP-24	V.K
VER #	REVISIONS	DATE	BY

I.B. STOREY
 Risk Engineering Experts

CHARLOTTETOWN PE
 VAUGHAN ON
 REDINGTON SHORES FL
 PLANO, TX

WWW.IBSTOREY.COM

STAMP

DRAWING NUMBER	24009 S-701		
DRAWING NAME	EQUIPMENT WEIGHTS AND HOUSEKEEPING PADS		
CLIENT	SPRINGFIELD PARK DISTRICT		
PROJECT	SPRINGFIELD-PLANT REPLACEMENT		
DRAWN BY	V.KOFANOV	CHECKED BY	J.RITCHIE
DATE	05-SEP-24	REVISION	1.0
SHEET SIZE	C	SHEET NO.	1 OF 1

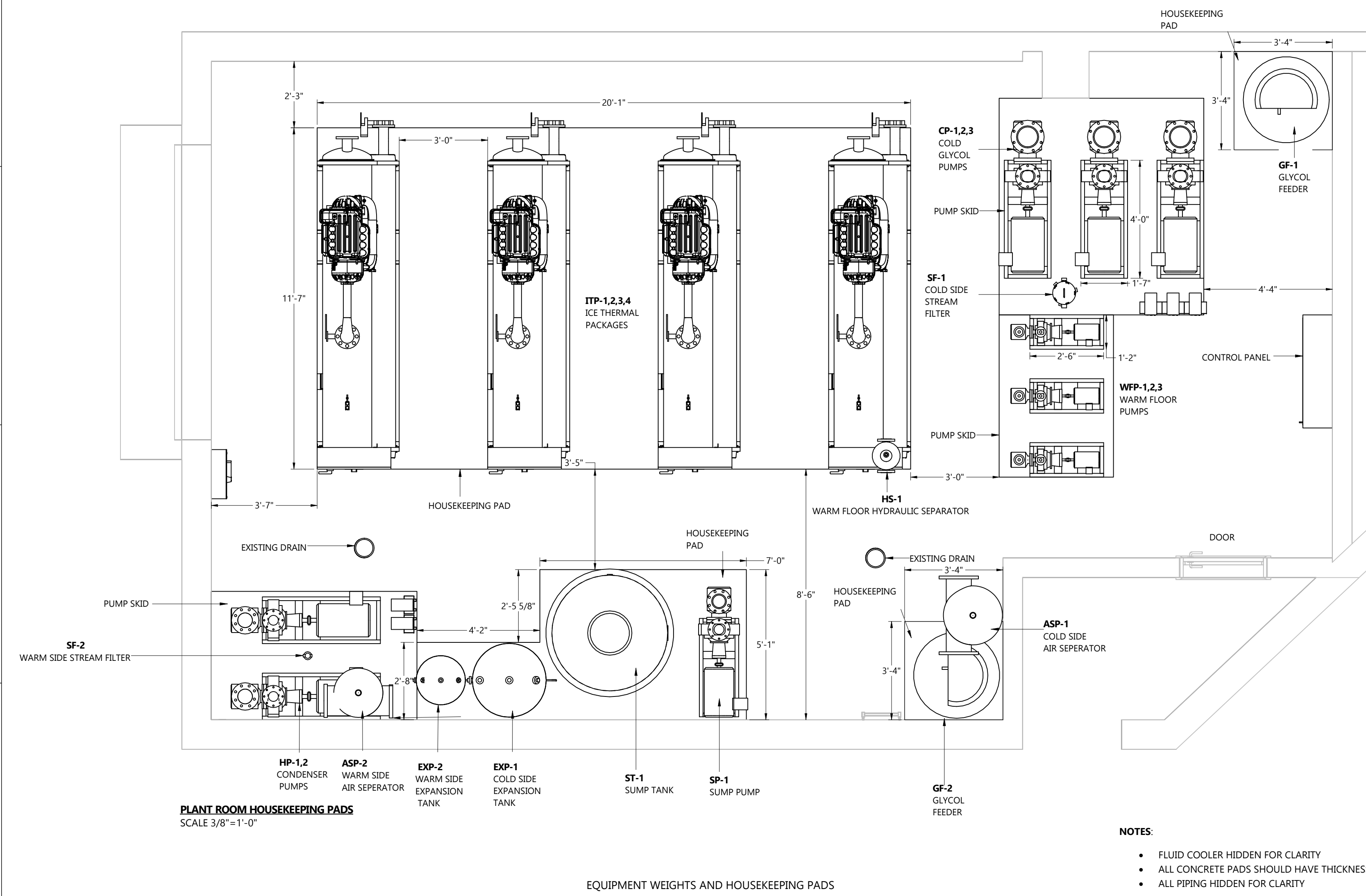

PLANT ROOM HOUSEKEEPING PADS
 SCALE 3/8"=1'-0"

EQUIPMENT WEIGHTS AND HOUSEKEEPING PADS

- NOTES:**
- FLUID COOLER HIDDEN FOR CLARITY
 - ALL CONCRETE PADS SHOULD HAVE THICKNESS OF 4"
 - ALL PIPING HIDDEN FOR CLARITY

24009 S-701

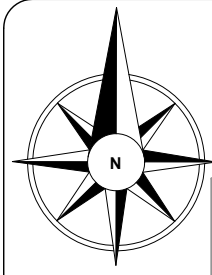

SITE KEY

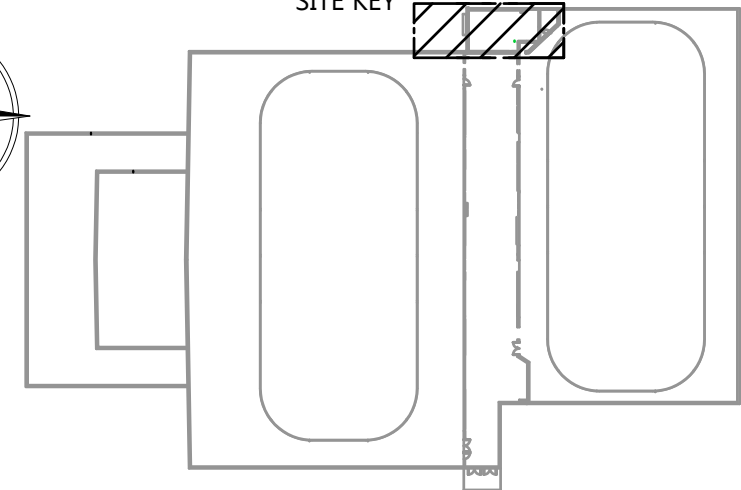
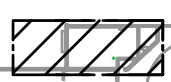

NOTES

REFERENCE DEFINITION	
SHEET COLUMN	SHEET ROW
SHEET NUMBER	(#, X#)

COPYRIGHT AND DISCLAIMER
 THIS WORK IS THE SOLE PROPERTY OF I.B. STOREY INC AND IS INTENDED SOLELY FOR THE INFORMATION OF THE CLIENT. ALL RIGHTS RESERVED. THE WORK MAY NOT BE REPRODUCED OR DISTRIBUTED, WHOLE OR IN PART, WITHOUT THE PRIOR WRITTEN PERMISSION OF I.B. STOREY INC.
 THIS DOCUMENT MAY NOT BE USED FOR ANY OTHER PROJECTS OR WITHOUT INVOLVEMENT OF I.B. STOREY INC. ANY USE WHICH A THIRD PARTY MAKES OF THE WORK, OR ANY RELIANCE ON OR DECISIONS TO BE MADE BASED ON IT, ARE THE RESPONSIBILITY OF SUCH THIRD PARTIES.

- NOT FOR CONSTRUCTION -
CONFIDENTIAL & PROPRIETARY

VER #	REVISIONS	DATE	BY
1.0	ISSUED FOR DETAILED DESIGN	05-SEP-24	V.K.



CHARLOTTETOWN PE
 VAUGHAN ON
 REDINGTON SHORES FL
 PLANO, TX

WWW.IBSTOREY.COM

DRAWING NUMBER		24009 P-701
DRAWING NAME		PLUMBING COORDINATION
CLIENT		SPRINGFIELD PARK DISTRICT
PROJECT		SPRINGFIELD-PLANT REPLACEMENT
DRAWN BY	CHECKED BY	
V.KOFANOV	J.RITCHIE	
DATE	REVISION	
05-SEP-24	1.0	
SHEET SIZE	SHEET NO.	
C	1 OF 1	

24009 P-701

1

2

3

4

5

ONE 1 1/4" FTP DCW WATER MAKE-UP INLET
 FOR WATER PIPING DETAILS REFER TO MP409,
 MP909

AFC-1

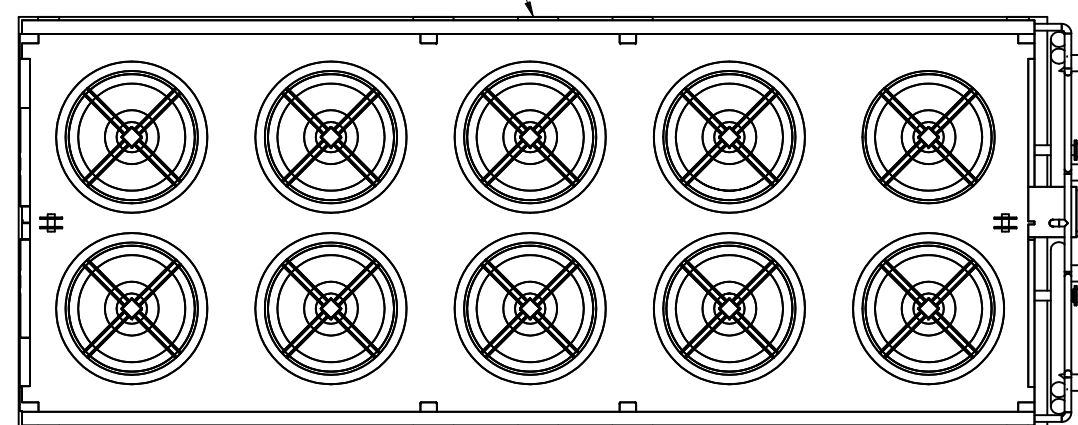

ONE 2" NTP DRAIN CONNECTION

EXISTING DRAIN

ONE WATER HOSE CONNECTION
 REQUIRED FILL RATE 1.5 GPM

EXISTING DRAIN

ONE DRIP TRAY FOR CP'S BY
 REFRIGERATION MECHANICAL CONTRACTOR

ONE WATER HOSE CONNECTION
 REQUIRED FILL RATE 1.5 GPM

GF-1

CP-1, 2, 3

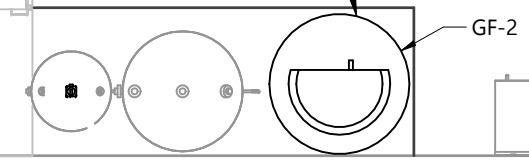
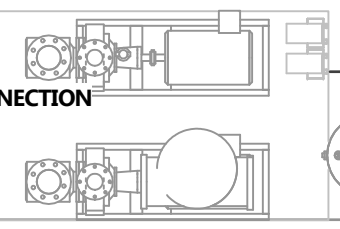

PLUMBING COORDINATION
 SCALE 1/4"=1'-0"

PLUMBING COORDINATION

A

B

C

D

E

Appendix C

Project Schedules

ID	Task Name	Start	Finish	2025												
				Jan	Feb	Mar	Apr	May	Jun	Jul	Aug	Sep	Oct	Nov	Dec	
1	Rink #2 Outage	3/3/2025	7/7/2025													
2	Rink #1 Outage	6/2/2025	9/24/2025													
3	Rinks #1 and #2 Not Available	6/2/2025	7/7/2025													
4	Rink #2 Connected to Rental Chiller and Ready for Use	7/7/2025	—													
5	Rink #1 Ready for Use	9/24/2025	—													

Schedule As Tendered



ID	Task Name	Start	Finish	Duration	2025											
					Jan	Feb	Mar	Apr	May	Jun	Jul	Aug	Sep	Oct	Nov	Dec
1	Step 5: Construct	1/1/2025	9/24/2025	38w 1d	[Gantt bar from Jan to Sep]											
2	Shop Drawings & Pre-Order Equipment	1/1/2025	1/28/2025	4w	[Gantt bar in Jan]											
3	Equipment Lead Time	2/3/2025	4/11/2025	10w	[Gantt bar from Feb to Apr]											
4	Secured Contractor	2/17/2025	2/17/2025	0w	[Milestone diamond in Feb]											
5	Rink #2 Ice Outage	3/3/2025	7/7/2025	18w 1d	[Gantt bar from Mar to Jul]											
6	R-22 Pump-Out and Storage (Plant & Rink #2)	3/3/2025	3/3/2025	1d	[Milestone bar in Mar]											
7	Rink #2 Detailed Boards and Glass Survey (Floor Anchors' Locations and Reconstruction Details)	3/4/2025	3/4/2025	1d	[Milestone bar in Mar]											
8	Rink #2 Boards and Glass Removal and Storage	3/4/2025	3/17/2025	2w	[Gantt bar in Mar]											
9	Rink #2 Piping and Header Trench Demolition	3/4/2025	3/17/2025	2w	[Gantt bar in Mar]											
10	Rink #2 Slab Demolition	3/4/2025	3/17/2025	2w	[Gantt bar in Mar]											
11	Rink #2 Rebuild (Slab, Piping, etc.)	3/18/2025	5/12/2025	8w	[Gantt bar from Mar to May]											
12	Floor Cure Time for Rink #2	5/13/2025	6/9/2025	4w	[Gantt bar from May to Jun]											
13	Re-Install Boards and Glass for Rink #2	6/10/2025	6/23/2025	2w	[Gantt bar in Jun]											
14	Install/Start Rental Chiller (Rink #2 Floor Charged with Glycol)	6/24/2025	6/24/2025	0w	[Milestone diamond in Jun]											
15	Ice Building for Rink #2	6/25/2025	7/7/2025	1w 4d	[Gantt bar in Jun]											
16	De-Energize Rink #1 Floor	7/7/2025	7/7/2025	1d	[Milestone bar in Jul]											
17	Rink #1 Ice Outage	6/2/2025	9/24/2025	16w 3d	[Gantt bar from Jun to Sep]											
18	Rink #1 Isolated and R-22 Pump-Out and Storage	6/2/2025	6/2/2025	1d	[Milestone bar in Jun]											
19	Rink #1 Boards Survey for Gates' Sizes and Locations	6/3/2025	6/3/2025	1d	[Milestone bar in Jun]											
20	Rink #1 Piping and Header Trench Demolition	6/3/2025	6/16/2025	2w	[Gantt bar in Jun]											
21	Rink #1 Slab Demolition (including Boards and Glass Removal)	6/3/2025	6/16/2025	2w	[Gantt bar in Jun]											
22	Rink #1 Rebuild (Slab, Piping, etc.)	6/17/2025	8/11/2025	8w	[Gantt bar from Jun to Aug]											
23	Floor Cure Time for Rink #1	8/12/2025	9/8/2025	4w	[Gantt bar from Aug to Sep]											
24	Install New Boards and Glass for Rink #1	9/9/2025	9/15/2025	1w	[Gantt bar in Sep]											
25	Connect Rinks #1 and #2 to New Plant	9/16/2025	9/16/2025	1d	[Milestone bar in Sep]											
26	Rink #1 Floor Charged with Glycol	9/17/2025	9/17/2025	1d	[Milestone bar in Sep]											
27	Ice Building for Rink #1	9/18/2025	9/24/2025	1w	[Gantt bar in Sep]											
28	Plant Demolition & Construction	6/2/2025	8/19/2025	11w 2d	[Gantt bar from Jun to Aug]											
29	Demolish Refrigeration Plant	6/2/2025	6/13/2025	2w	[Gantt bar in Jun]											
30	Install New Refrigeration Plant	6/16/2025	8/8/2025	8w	[Gantt bar from Jun to Aug]											
31	Contractor Functional Commissioning of Ice Plant	8/11/2025	8/19/2025	1w 2d	[Gantt bar in Aug]											
32	Step 6: Closeout	8/20/2025	10/23/2025	9w 2d	[Gantt bar from Aug to Oct]											
33	I.B. Storey Performance Commissioning	8/20/2025	10/8/2025	7w 1d	[Gantt bar from Aug to Oct]											
34	Identification & Completion of Deficiencies	9/3/2025	10/22/2025	7w 1d	[Gantt bar from Sep to Oct]											
35	Project Closeout & Turn-Over to Facility	10/23/2025	10/23/2025	1d	[Milestone bar in Oct]											

Schedule As Tendered



Appendix D

Bidder Evaluation Criteria

Table 1: Evaluation Matrix

DESCRIPTION OF FACTOR	WEIGHT	TOTAL WEIGHT FOR SECTION
A. Understanding of Scope of Work		
COMPLIANCE WITH TENDER: A brief description of the company. Include a history of the company size, location, and areas of professional expertise. Specification of recommended installation, with detail that meets or exceeds the specifications outlined in the scope of work.	20	/30
DEMONSTRATED PERFORMANCE OF PROPOSED EQUIPMENT/SYSTEM: Proponents must stipulate that installation will occur as necessary to fulfill applicable codes and standards as they apply to refrigeration and mechanical systems.	10	
B. Proponents' Capability and Experience		
DESCRIPTION OF KEY PERSONNEL AND THEIR INVOLVEMENT WITH THE PROJECT: A list of the key personnel who would be involved including any sub-consultants or sub-contractors.	10	/35
DEMONSTRATED TECHNICAL ABILITY (PREVIOUS EXPERIENCE PROVIDING SIMILAR SERVICES): Clearly outline demonstrated experience and understanding of mechanical concepts, including a summary of projects undertaken in the recreation sector, a summary of projects involving refrigeration system installations, and a summary of projects involving specialized rink floor construction. Description of refrigeration qualifications/certifications.	10	
PERFORMANCE BASED CONSTRUCTION EXPERIENCE IN SIMILAR APPLICATIONS: Only companies having successfully completed a minimum of 5 separate mechanical/refrigeration system installations shall be qualified to bid this project. To establish competency and proof of ability the contractor shall submit a list of references including phone numbers and contacts.	10	
PROPOSED CONSTRUCTION SCHEDULE: Provide a proposed construction schedule for the installation of the mechanical refrigeration plant replacement and specialized rink floor construction project. A schedule of any required demolition and erection of walls to enable equipment installation and relocation must be submitted for approval.	5	
C. Cost of Service		
COST OF SERVICE: Proponent shall provide the total cost of the project. The proposed cost is to be turnkey. Taxes are to be added as a separate item.	35	/35
Subtotal		/100

MEMORANDUM

TO: ALL BIDDERS **COMPANY:** N/A
FROM: I.B. STOREY INC.
SUBJECT: 24-009-ADDENDUM #1
DATE: 29-OCT-24

The following addendum is being provided for *24-009 SPD Tender Project Manual (With Evaluation Criteria) v2.0*

Addendum #1 Specification Adjustment

1. **Was:** SPD Tender Project Manual (with Evaluation Criteria), page 5

- MILESTONE DATES

Tender Posting	14-Oct-24
Non-Mandatory Pre-Bid Meeting	24-Oct-24
Deadline for Questions	29-Oct-24
Tender Closing	01-Nov-24
Substantial Completion	24-Sep-25

Is Now: SPD Tender Project Manual (with Evaluation Criteria), page 5

- MILESTONE DATES

Tender Posting	14-Oct-24
Non-Mandatory Pre-Bid Meeting	24-Oct-24
Deadline for Questions	06-Nov-24
Tender Closing	12-Nov-24
Substantial Completion	24-Sep-25

2. **Was:** SPD Tender Project Manual (with Evaluation Criteria), page 45

- Section: "**LIQUIDATED DAMAGES**"

Is Now: SPD Tender Project Manual (with Evaluation Criteria), page 45

- [Removed]

3. **Was:** SPD Tender Project Manual (with Evaluation Criteria), Division 13 18 00 Part 1 Ice Rink General Scope of Work, Item 1.1.1.10.2.1:

.1 Rink #2 R-22 Pump-Out: 03-Mar-25

Is Now: SPD Tender Project Manual (with Evaluation Criteria), Division 13 18 00 Part 1 Ice Rink General Scope of Work, Item 1.1.1.10.2.1:

.1 Rink #2 R-22 Pump-Out: 02-Jun-25

4. **Was:** SPD Tender Project Manual (with Evaluation Criteria), Division 13 18 00 Part 1 Ice Rink General Scope of Work, Item 1.5.1.1:

.1 The Contractor shall be regularly engaged in the installation and service of mechanical, refrigeration, and heating systems in Illinois.

Is Now: SPD Tender Project Manual (with Evaluation Criteria), Division 13 18 00 Part 1 Ice Rink General Scope of Work, Item 1.5.1.1:

.1 The Contractor shall be regularly engaged in the installation and service of mechanical, refrigeration, and heating systems

5. **Was:** SPD Tender Project Manual (with Evaluation Criteria), Division 13 18 00 Part 3 Automation Scope of Work, Item 3.4.5:

.5 There will be a \$5,000 cash allowance for IT infrastructure to be coordinated with the Consultant.

Is Now: SPD Tender Project Manual (with Evaluation Criteria), Division 13 18 00 Part 3 Automation Scope of Work, Item 3.4.5:

.5 [Removed]

6. **Was:** SPD Tender Project Manual (with Evaluation Criteria), Division 13 18 00 Part 5 Ice Rink Dasher Boards Scope of Work, Item 5.4.1.1:

.1 Work to be completed by a professional survey engineer licensed in the State of Illinois.

Is Now: SPD Tender Project Manual (with Evaluation Criteria), Division 13 18 00 Part 5 Ice Rink Dasher Boards Scope of Work, Item 5.4.1.1:

.1 Work to be completed by a professional survey engineer.